

**INSTRUCTION MANUAL
GUIDE D'UTILISATION
MANUAL DE INSTRUCCIONES**

INSTRUCTIVO DE OPERACIÓN, CENTROS DE SERVICIO Y PÓLIZA
DE GARANTÍA. **ADVERTENCIA:** LÉASE ESTE INSTRUCTIVO ANTES
DE USAR EL PRODUCTO.

DEWALT®

**DW708 Sliding Compound Miter Saw
DW708 Scie à onglets mixtes coulissants
DW708 Sierra de ángulo compuesto (ingleteadora) corrediza**

IF YOU HAVE ANY QUESTIONS OR COMMENTS ABOUT THIS OR ANY D_EWALT TOOL,
CALL US TOLL FREE AT:

1-800-4-DEWALT (1-800-433-9258)

This product is covered under U.S. Patent No. 5,199,343 and
other patents pending.

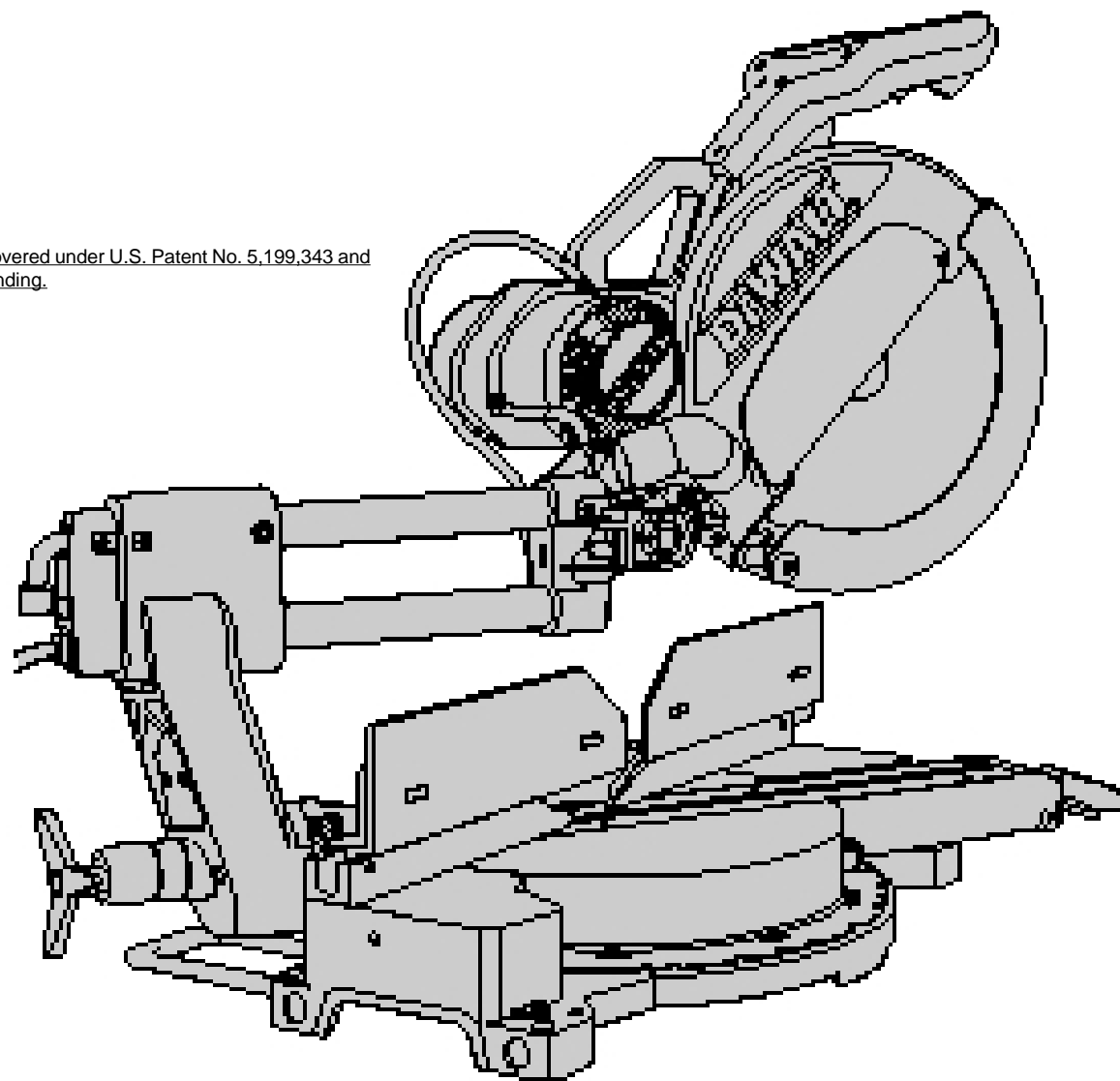

D_EWALT... BUILT JOBSITE TOUGH

D_EWALT high performance industrial tools are made for America's toughest industrial and construction applications. The design of every tool in the line – from drills to sanders to grinders – is the result of rigorous use on jobsites and throughout industry. Each tool is produced with painstaking precision using advanced manufacturing systems and intense quality control. Every tool is checked before it leaves the factory to make sure that it meets your standards for durability, reliability and power.

D_EWALT

Built Jobsite Tough...WE GUARANTEE IT.

TABLE OF CONTENTS

| | | | |
|---------------------------------------|---|---|----|
| SAFETY INSTRUCTIONS | 2 | SWITCH | 9 |
| ADDITIONAL SAFETY RULES..... | 2 | CUTTING WITH YOUR SAW | 9 |
| DOUBLE INSULATION/POLARIZED PLUG..... | 2 | CROSSCUTS..... | 9 |
| EXTENSION CORDS | 2 | BEVEL CUTS..... | 9 |
| ELECTRICAL CONNECTION..... | 4 | QUALITY OF CUT | 10 |
| UNPACKING YOUR SAW | 4 | BODY AND HAND POSITION | 10 |
| FAMILIARIZATION | 4 | CLAMPING THE WORKPIECE | 10 |
| CONTROLS | 4 | SUPPORT FOR LONG PIECES..... | 10 |
| SPECIFICATIONS | 4 | CUTTING PICTURE FRAMES, SHADOW BOXES AND OTHER FOUR SIDED PROJECTS | 10 |
| OPTIONAL ATTACHMENTS/ACCESSORIES..... | 5 | CUTTING TRIM MOULDING AND OTHER FRAMES..... | 11 |
| BENCH MOUNTING | 6 | CUTTING COMPOUND MITERS | 11 |
| TRANSPORTING THE SAW | 7 | DUAL RANGE MITER SCALE | 11 |
| ADJUSTMENTS..... | 7 | VERNIER SCALE | 11 |
| MITER SCALE ADJUSTMENT | 7 | CUTTING BASE MOLDINGS | 12 |
| MITER POINTER ADJUSTMENT..... | 7 | CUTTING CROWN MOLDING | 13 |
| MITER LOCK/DETENT ROD ADJUSTMENT..... | 7 | SPECIAL CUTS | 15 |
| BEVEL STOP | 8 | INSTALLING A NEW SAW BLADE | 15 |
| FENCE ADJUSTMENT..... | 8 | REMOVING AND REPLACING BELT | 16 |
| GUARD ACTUATION AND VISIBILITY | 9 | MAINTENANCE | 16 |
| AUTOMATIC ELECTRIC BRAKE | 9 | WARRANTY..... | 16 |
| RAIL GUIDE ADJUSTMENT..... | 9 | TROUBLE SHOOTING GUIDE..... | 17 |
| BRUSHES..... | 9 | | |
| OPERATION | 9 | | |

IMPORTANT SAFETY INSTRUCTIONS (FOR ALL TOOLS)

⚠ WARNING: For your own safety read instruction manual before operating sliding compound miter saw.

⚠ WARNING: When using electric tools, basic safety precautions should always be followed to reduce risk of fire, electric shock, and personal injury, including the following:

Double Insulation

Double insulated tools are constructed throughout with two separate layers of electrical insulation or one double thickness of insulation between you and the tool's electrical system. Tools built with this insulation system are not intended to be grounded. As a result, your tool is equipped with a two prong plug which permits you to use extension cords without concern for maintaining a ground connection.

NOTE: Double insulation does not take the place of normal safety precautions when operating this tool. The insulation system is for added protection against injury resulting from a possible electrical insulation failure within the tool.

⚠ CAUTION: WHEN SERVICING USE ONLY IDENTICAL REPLACEMENT PARTS. Repair or replace damaged cords.

Polarized Plugs

To reduce the risk of electric shock, this equipment has a polarized plug (one blade is wider than the other). This plug will fit in a polarized outlet only one way. If the plug does not fit fully into the outlet, reverse the plug. If it still does not fit, contact a qualified electrician to install the proper outlet. Do not change the plug in any way.

Important Safety Instructions

- **KEEP GUARDS IN PLACE** and in working order.
- **REMOVE ADJUSTING KEYS AND WRENCHES.** Form habit of checking to see that keys and adjusting wrenches are removed from tool before turning it on.
- **KEEP WORK AREA CLEAN.** Cluttered areas and benches invite injuries.
- **DON'T USE IN DANGEROUS ENVIRONMENT.** Don't use power tools in damp or wet locations, or expose them to rain. Keep work area well lighted.
- **KEEP CHILDREN AWAY.** All visitors should be kept safe distance from work area.
- **MAKE WORKSHOP KID PROOF** with padlocks, master switches, or by removing starter keys.
- **DON'T FORCE TOOL.** It will do the job better and safer at the rate for which it was designed.
- **USE RIGHT TOOL.** Don't force tool or attachment to do a job for which it was not designed.
- **USE PROPER EXTENSION CORD.** Make sure your extension cord is in good condition. When using an extension cord, be sure to use one heavy enough to carry the current your product will draw. An undersized cord will cause a drop in line voltage resulting in loss of power and overheating. The following table shows the correct size to use depending on cord length and nameplate ampere rating. If in doubt, use the next heavier gage. The smaller the gage number, the heavier the cord.

Minimum Gage for Cord Sets

| Volts | Minimum Gage for Cord Sets | | Total Length of Cord in Feet | | |
|---------------|----------------------------|------|------------------------------|-----------------|---------|
| | 0-25 | 0-50 | 26-50 | 51-100 | 101-150 |
| 120V | | | 26-50 | 51-100 | 101-150 |
| 240V | | | 51-100 | 101-200 | 201-300 |
| Ampere Rating | | AWG | | | |
| More Than | Not more Than | | | | |
| 0 | - 6 | 18 | 16 | 16 | 14 |
| 6 | - 10 | 18 | 16 | 14 | 12 |
| 10 | - 12 | 16 | 16 | 14 | 12 |
| 12 | - 16 | 14 | 12 | Not Recommended | |

- **WEAR PROPER APPAREL.** Do not wear loose clothing, gloves, neckties, rings, bracelets, or other jewelry which may get caught in moving parts. Non-slip footwear is recommended. Wear protective hair covering to contain long hair.
- **ALWAYS USE SAFETY GLASSES.** Also use face or dust mask if cutting operation is dusty. Everyday eyeglasses only have impact resistant lenses, they are not safety glasses.
- **DON'T OVERREACH.** Keep proper footing and balance at all times.
- **MAINTAIN TOOLS WITH CARE.** Keep tools sharp and clean for best and safest performance. Follow instructions for lubricating and changing accessories.
- **DISCONNECT TOOLS** before servicing; when changing accessories, such as blades, bits, cutters, and the like.
- **REDUCE THE RISK OF UNINTENTIONAL STARTING.** Make sure switch is in off position before plugging in.
- **USE RECOMMENDED ACCESSORIES.** Consult the instruction manual for recommended accessories. The use of improper accessories may cause risk of injury to persons.
- **NEVER STAND ON TOOL.** Serious injury could occur if the tool is tipped or if the cutting tool is unintentionally contacted.
- **CHECK DAMAGED PARTS.** Before further use of the tool, a guard or other part that is damaged should be carefully checked to determine that it will operate properly and perform its intended function—check for alignment of moving parts, binding of moving parts, breakage of parts, mounting, and any other conditions that may affect its operation. A guard or other part that is damaged should be properly repaired or replaced.
- **NEVER LEAVE TOOL RUNNING UNATTENDED.** TURN POWER OFF. Don't leave tool until it comes to a complete stop.
- **REPLACEMENT PARTS.** When servicing, use only identical replacement parts.

Additional Safety Rules for Sliding Compound Miter Saw

- Wear eye protection.
- Keep hands out of path of saw blade. **NEVER CUT A PIECE WHERE HAND WOULD BE 6" (152 mm) OR LESS FROM BLADE.**
- Do not operate saw without guards in place.
- Do not perform any operation freehand.
- Never reach in back of saw blade.
- Turn off tool and wait for saw blade to stop before moving workpiece or changing settings.
- Disconnect power before changing blade or servicing.
- Blade adjustment is to be made only with the power off and the blade stopped.
- Never use saw without kerf plate.
- Replace kerf plate when kerf exceeds blade width by 1/8" (3 mm).
- To reduce risk of injury, return carriage to the full rear position after each crosscut operation.

- **⚠ CAUTION:** FAILURE TO HEED THESE WARNINGS MAY RESULT IN PERSONAL INJURY AND SERIOUS DAMAGE TO THE SAW.
- DO-Protect electric supply line with at least a 15 ampere time-delay fuse or a circuit breaker.
- DO-Make certain the blade rotates in the correct direction and that the teeth at the bottom of the blade are pointing to the rear of the sliding compound miter saw.
- DO use stabilizer bars at all times.
- DO-Be sure all clamp handles and knobs are tight before starting any operation.
- DO-Be sure all blade and clamp washers are clean and recessed sides of collars are against blade. Tighten arbor screw securely.
- DO- Keep saw blade sharp and properly set.
- DO-Keep motor air slots free of chips and dirt.
- DO-Use blade guards at all times.
- DO-Keep hands out of path of saw blade.
- DO-Shut off power, disconnect cord from power source and wait for saw blade to stop before servicing or adjusting tool.
- DO-Support long work with an outboard tool rest.
- DON'T-Attempt to operate on anything but designated voltage.
- DON'T-Operate unless all clamp handles are tight.
- DON'T- Use blades larger or smaller than those which are recommended.
- DON'T- Wedge anything against fan to hold motor shaft.
- DON'T-Force cutting action. (Stalling or partial stalling of motor can cause major damage. Allow motor to reach full speed before cutting.)
- DON'T- Cut ferrous metals (Those with any iron or steel content) or any masonry.
- DON'T-Use abrasive wheels. The excessive heat and abrasive particles generated by them will damage the saw.
- DON'T use any abrasive blades.
- DON'T-Allow anyone to stand behind saw.
- DON'T-Apply lubricants to the blade when it's running.
- DON'T-Place either hand in the blade area when the saw is connected to the power source.
- DON'T-Use blades rated less than 4800 R.P.M.
- DON'T-Attempt to cut small pieces 6" (152mm) without clamping.
- DON'T-Operate saw without guards in place.
- DON'T-Perform any operation freehand.
- DON'T-Reach around or behind saw blade.
- DON'T-Place hands closer than 6 inches from the saw blade.
- DON'T - Reach underneath the saw unless it is turned off and unplugged.
- DON'T - Move either hand from saw or workpiece or raise arm until blade has stopped.
- **⚠ CAUTION:** Do not connect unit to electrical power source until complete instructions are read and understood.
- **⚠ CAUTION:** Some wood contains preservatives such as copper chromium arsenate (CCA) which can be toxic. When cutting these materials extra care should be taken to avoid inhalation and minimize skin contact.

For your convenience and safety, the following warning labels are on your sliding compound miter saw.

- ON MOTOR HOUSING:

⚠ WARNING: FOR YOUR OWN SAFETY, READ INSTRUCTION MANUAL BEFORE OPERATING MITER SAW.

ALWAYS WEAR EYE PROTECTION.
DOUBLE INSULATED. WHEN SERVICING, USE ONLY IDENTICAL REPLACEMENT PARTS.

DO NOT EXPOSE TO RAIN OR USE IN DAMP LOCATIONS.

- ON MOVING FENCE:

⚠ ALWAYS ADJUST FENCE PROPERLY BEFORE USE. CLAMP SMALL PIECES BEFORE CUTTING. SEE MANUAL.

- ON GUARD:

DANGER – KEEP AWAY FROM BLADE.



- ON ARBOR COVER:

⚠ WARNING:

FOR YOUR OWN SAFETY READ INSTRUCTION MANUAL BEFORE OPERATING MITER SAW.

KEEP HANDS OUT OF PATH OF SAW BLADE.

DO NOT OPERATE SAW WITHOUT GUARDS IN PLACE.

ALWAYS TIGHTEN ADJUSTMENT KNOBS BEFORE USE.

DO NOT PERFORM ANY OPERATION FREEHAND.

NEVER REACH IN BACK OF SAW BLADE.

NEVER CROSS ARMS IN FRONT OF BLADE.

TURN OFF TOOL AND WAIT FOR SAW BLADE TO STOP BEFORE MOVING WORKPIECE, CHANGING SETTINGS OR MOVING HANDS.

DISCONNECT POWER BEFORE CHANGING BLADE OR SERVICING.

TO REDUCE THE RISK OF INJURY, RETURN CARRIAGE TO THE FULL REAR POSITION AFTER EACH CROSSCUT OPERATION.

REAR STABILIZER BARS MUST BE IN PLACE DURING USE.

THINK! YOU CAN PREVENT ACCIDENTS.



- ON BASE:

- ON STABILIZERS:

REAR STABILIZER BARS MUST BE IN PLACE DURING USE

Electrical Connection

Be sure your power supply agrees with the nameplate marking. AC ONLY means that your saw will operate on alternating current only. A voltage decrease of 10 percent or more will cause a loss of power and overheating. All DeWalt tools are factory tested. If this tool does not operate, check the power supply.

Unpacking Your Saw

Check the contents of your sliding compound miter saw carton to make sure that you have received all parts. In addition to this instruction manual, the carton should contain:

1. One No. DW708 sliding compound miter saw.
2. One No. 340984-20, 60 tooth
DeWALT 12" (305mm) dia. saw blade
3. One blade wrench in wrench pocket shown in Figure 2
4. Two base stabilizers

Familiarization

Your sliding compound miter saw is fully assembled (except for the stabilizers) in the carton. Open the box and lift the saw out by the lifting handle and the rail, as shown in Figure 1.

Place the saw on a smooth, flat surface such as a workbench or strong table.

Examine Figures 2 & 3 to become familiar with the saw and its various parts. The following section on adjustments will refer to these terms and you must know what and where the parts are.

Press down lightly on the operating handle and pull out the lock down pin, as shown in Figure 4. Gently release the downward pressure and allow the arm to rise to its full height.

Controls

Your sliding compound miter saw has several main controls, which will be discussed briefly here. For more information on these controls, see the respective sections later in the manual.

MITER CONTROL

The miter lock/adjustment lever and trigger allows you to miter your saw 50° left and 60° right. To miter the saw, lift the miter lock/adjustment lever, squeeze the detent trigger (Figure 2) and set the miter angle desired on the miter scale (Figure 2). Push down on the miter lock lever to lock the saw table in-place.

TRIGGER SWITCH

The trigger switch (Figure 3) turns your saw on and off. A hole is provided in the trigger for insertion of a padlock to lock the saw off.

BEVEL STOP

The bevel adjustment/lock handle (Figure 2) allows you to bevel your saw 48° left or right (Figure 13). To loosen the lever and adjust the bevel setting, turn the handle counterclockwise, the saw head bevels easily to the left or right. To tighten, turn the handle clockwise. Bevel degree markings are on the bottom rear of the saw arm.

BEVEL STOP OVERRIDE

The bevel stop override (Figure 2) allows you to override the built-in bevel stop at 0°.

The saw will automatically stop at 0° when brought up from the left. To move past 0° to the right, press the bevel stop override. The saw will automatically stop at 45° on the left or right.

BEVEL STOP PINS

The bevel stop pins (Figure 2) allow you to override built-in bevel stops at 0° and 45° left and right.

Each bevel stop pin has two positions: engaged and disengaged. When the 0° (middle) bevel stop pin is engaged, the saw will stop at 0° when brought up from the left. To move past 0° to the right, disengage the bevel stop pin. **To disengage:**

- Bevel saw at least 5° away from stop
- Push stop pin in completely and rotate it 90° COUNTERCLOCKWISE until it stops.
- Release bevel stop pin and allow it to spring outward to its disengaged position.

To reset the 0° bevel stop, re-engage the bevel stop pin. **To re-engage:**

- Bevel saw at least 5° away from stop
- Push stop pin in completely and rotate it 90° CLOCKWISE until it stops.
- Release bevel stop pin and allow it to spring outward to its engaged position.

FIG. 1



FIG. 1A



NOTE: Saw will not adjust from a right bevel position to a left bevel position with the 0° (middle) bevel stop pin engaged.

The bevel stop pins at 45° left and right stop position can be disengaged to 48° following the procedure above.

RAIL LOCK KNOB

The rail lock knob (Figure 2) allows you to lock the saw head firmly to keep it from sliding on the rails. This is necessary when making certain adjustments or when transporting the saw.

GROOVING STOP

The grooving stop allows for groove cutting.

Flipping the grooving lever toward the front of the saw and adjusting the thumbscrew changes the depth of the groove cut. Flipping the lever toward the rear of the saw bypasses this feature.

MOVABLE FENCE ADJUSTMENT KNOBS

The fence adjustment knobs allow adjustment of the left or right fence. Loosen the plastic adjustment knob (behind the fence) and slide the fence in or out. Retighten before operating the saw.

Specifications

CAPACITY OF CUT

50° miter left, 60° miter right

48 degree bevel left and right

| Miter | Bevel | Max Height | Max Width |
|---------|-------|------------|-----------|
| 0° | 0° | 4.7" | 12" |
| 45 L&R° | 0° | 4.7" | 8.5" |
| 0° | 45° L | 3.2" | 12" |
| 0° | 45° R | 1.7" | 12" |

FIG. 2

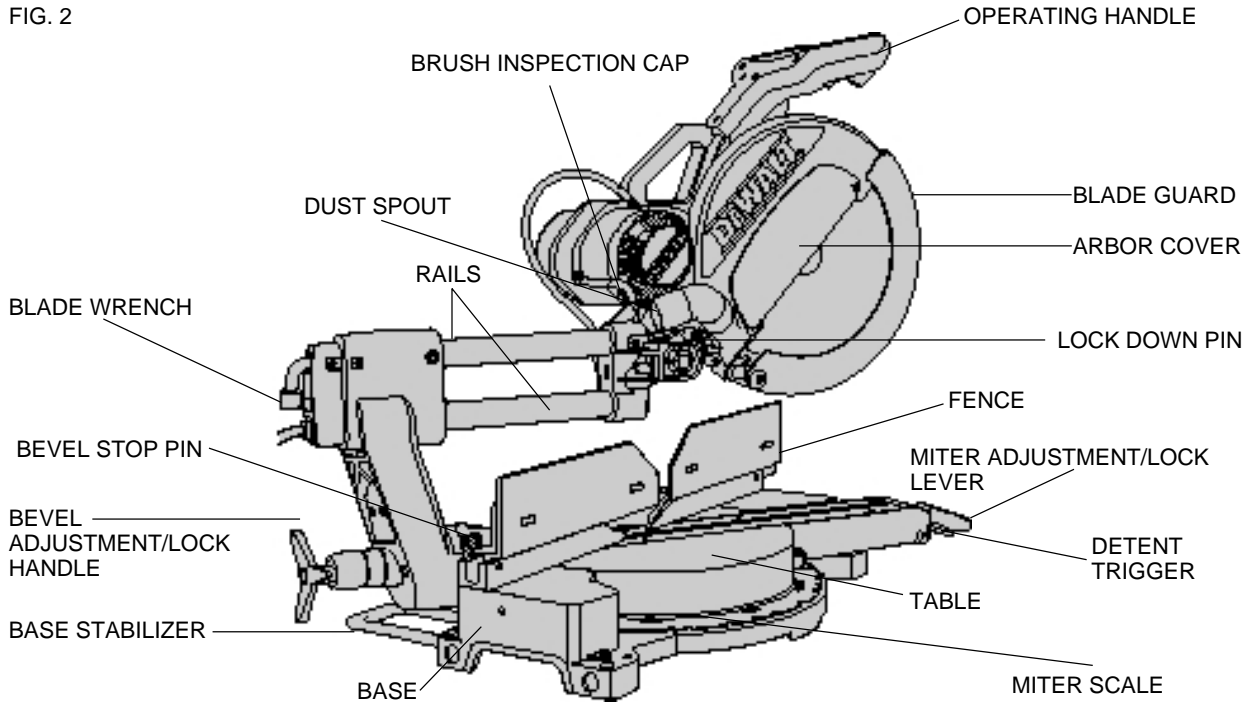

FIG. 3

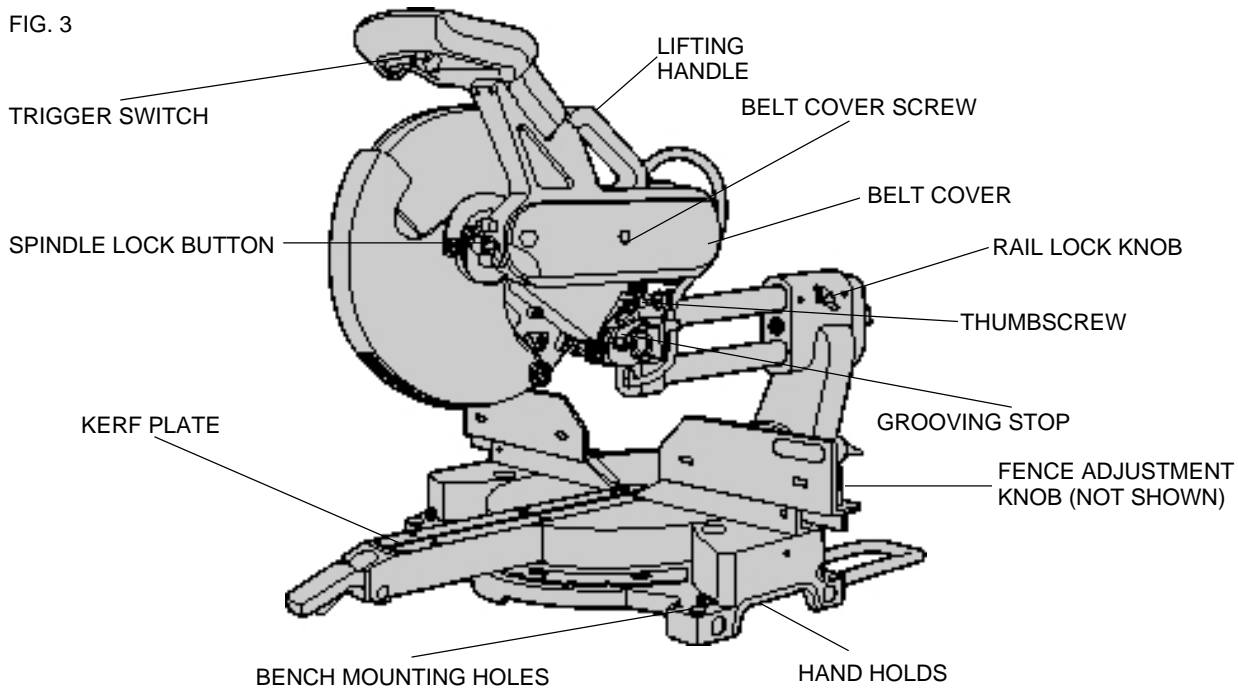

FIG. 3A



BEVEL STOP PIN:
ENGAGED



BEVEL STOP PIN:
DISENGAGED

FIG. 3B

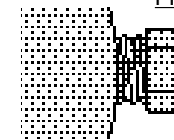

BEVEL STOP:
ENGAGED

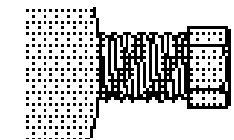

BEVEL STOP :
DISENGAGED

DRIVE

120 Volt Motor

- 1700 Watts
- 13 Amp Motor
- 4000 RPM
- Cut Helical Gears with Roller Bearings
- Multi-V Belt
- 60 Tooth Carbide Blade
- Automatic Electric Brake

Optional Attachments/Accessories

⚠ WARNING: For safe operation, read instruction literature included with attachments/accessories.

Extension Kit: DW7080

Used to support long overhanging workpieces, the work support is user assembled. Your saw table is designed to accept two work supports; one on each side. One set stores conveniently under the saw table.

Adjustable Length Stop: DW7051

Requires the use of one work support (see above). It is used to make repetitive cuts of the same length from 0 to 42" (0 to 106cm).

Material Clamp: DW7082

Used for firmly clamping workpiece to the saw table for precision cutting.

Crown Stop: DW7084

Used for precision cutting of crown molding.

Dust Bag: DW7053

Equipped with a zipper for easy emptying.

NOTE: Spout has a provision to attach a vacuum hose to collect sawdust. Proper orientation of dust bag is necessary to avoid interference during operation of saw. If interference cannot be avoided, dust bag must be removed. ALWAYS MAKE A DRY RUN WITHOUT POWER BEFORE MAKING ANY CUTS.

Kit Box: DW7056

Used to store and transport DW708 accessories.

SAW BLADES: ALWAYS USE 12" (305mm) SAW BLADES. SPEED RATING MUST BE AT LEAST 4800 RPM. USE OF SMALLER DIAMETER BLADES MAY CAUSE SEVERE DAMAGE TO SAW.

| Application | Blade Descript. | No. of Teeth | Type of Cut |
|--|---|-----------------|------------------------------------|
| Fine Trim Molding | Precision Ground Carbide | 60-100 | Very Smooth Splinter Free |
| Trim, Framing, Pressure Treated Decking | Combination Multi-Purpose | 32-60 | Smooth Fast Cut |
| Aluminum | Non-Ferrous Metal Cutting Negative Rake Teeth | 60-80 | — |

Stabilizers

Your saw includes two base stabilizers. These must be installed before using your saw. Insert the stabilizers into the holes in the back of the unit, as shown in Figure 5. Move the stabilizers in or out until they contact the work surface. Then tighten the screws in the base to fasten the stabilizers.

Bench Mounting

Holes are provided to facilitate bench mounting, as shown in Figure 3. (Two different sized holes are provided to accommodate different sizes of screws. Use either hole, it is not necessary to use both.) Always mount your saw firmly to prevent movement. To enhance the tool's portability, it can be mounted to a piece of 1/2" (12.7mm) or thicker plywood which can then be clamped to your work support or moved to other job sites and re-clamped.

NOTE: If you elect to mount your saw to a piece of plywood, make sure that the mounting screws don't protrude from the bottom of the wood. The plywood must sit flush on the work support. When clamping the saw to any work surface, clamp only on the clamping bosses where the mounting screw holes are located. Clamping at any other point will interfere with the proper operation of the saw.

FIG. 4

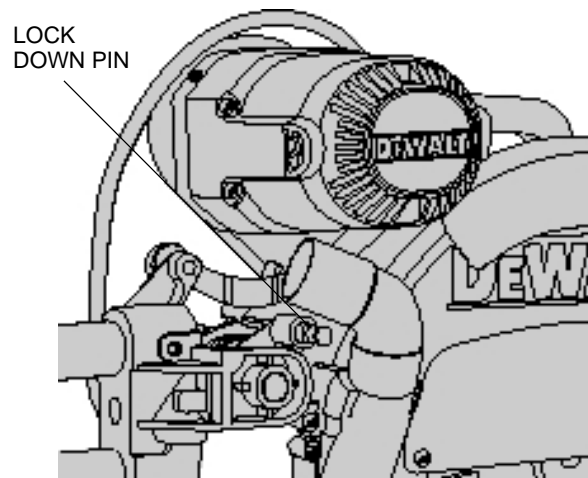

FIG. 6

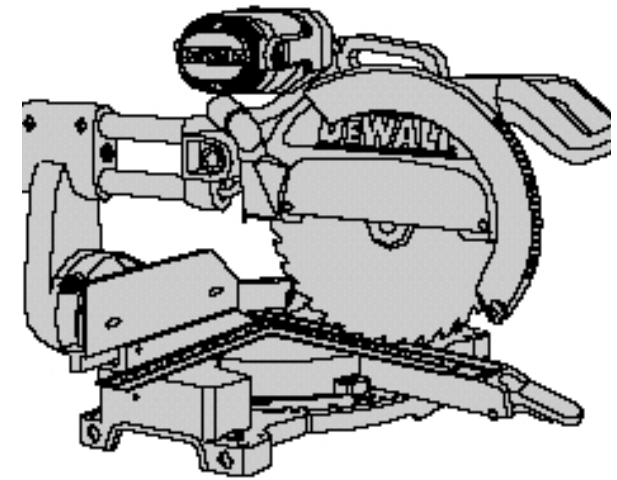

FIG.5

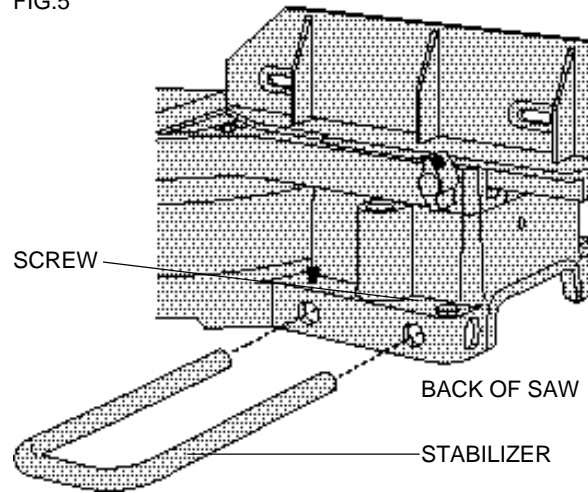

FIG. 7

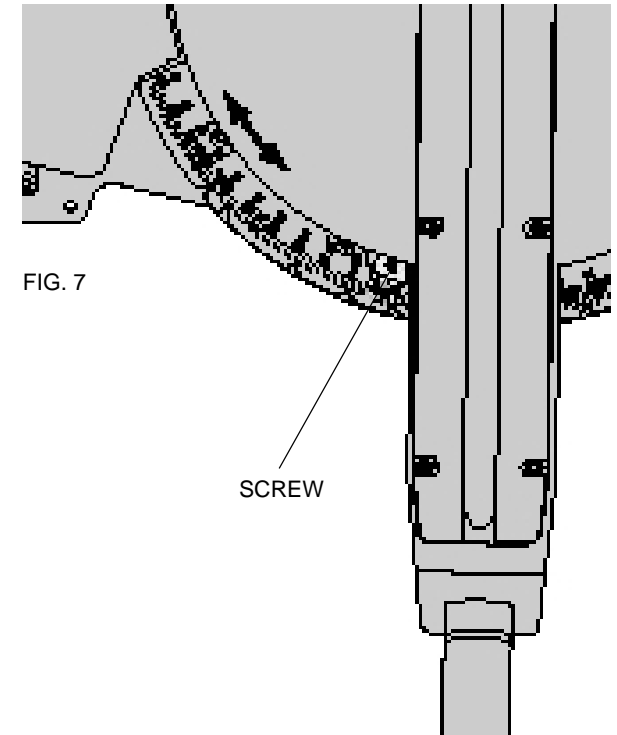

FIG. 8

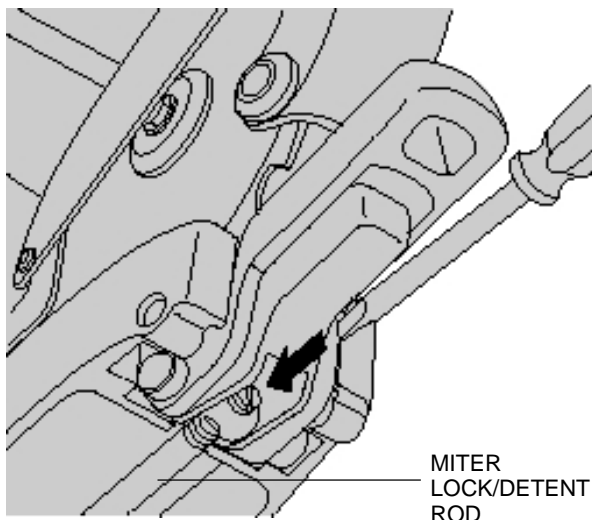

FIG. 10

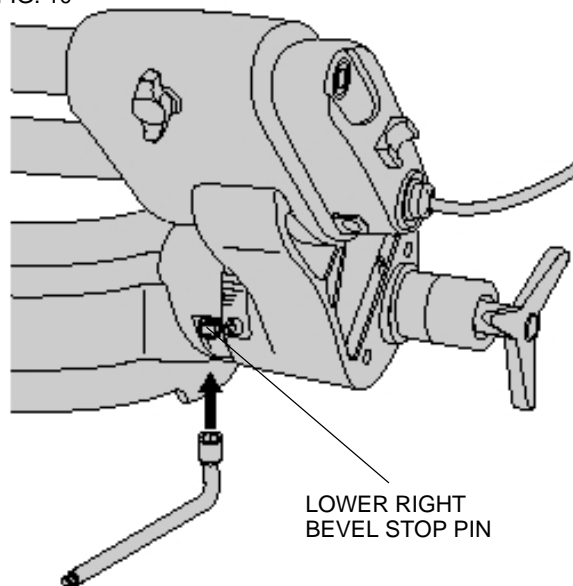

FIG. 9

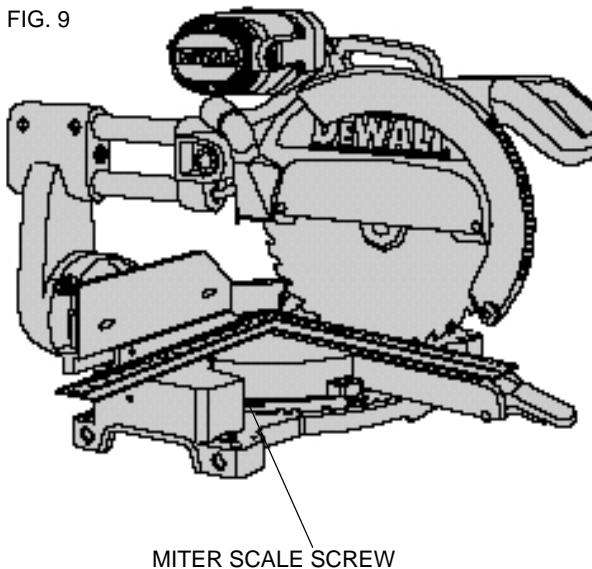
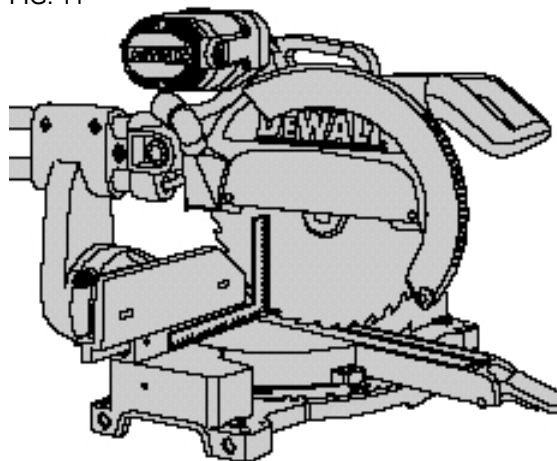

FIG. 11



⚠ CAUTION: To prevent binding and inaccuracy, be sure the mounting surface is not warped or otherwise uneven. If the saw rocks on the surface place a thin piece of material under one saw foot until the saw sits firmly on the mounting surface.

Transporting the Saw

TURN OFF AND UNPLUG THE SLIDING COMPOUND MITER SAW BEFORE ATTEMPTING TO MOVE IT OR MAKE ANY ADJUSTMENTS.

Use the lock down pin when carrying the saw from one place to another. The lock down pin is not to be used for any cutting operation, and is for carrying and storage only. When transporting the saw, always lock the head in the down position, miter the saw fully to the right (60° miter), lock the miter adjustment/lock lever, lock the rail lock knob with the head fully forward, slide the fences completely inward, and lock the bevel adjustment/lock lever with the saw at a 0° bevel. Always use the carrying hand holds in the base to transport the saw. Carry the saw as shown in Figure 1A.

Adjustments

PERFORM ALL ADJUSTMENTS WITH THE SLIDING COMPOUND MITER SAW UNPLUGGED.

NOTE: Your sliding compound miter saw is fully and accurately adjusted at the factory at the time of manufacture. If readjustment due to shipping and handling or any other reason is required, follow the steps below to adjust your saw.

Once made, these adjustments should remain accurate.

MITER SCALE ADJUSTMENT

Place a square against the saw's base, fence and blade, as shown in Figure 6. (Do not touch the tips of the blade teeth with the square. To do so will cause an inaccurate measurement.) Lift the miter clamp lever and swing the miter arm until the miter latch locks it at the 0 miter position. If the saw blade is not exactly perpendicular to the fence, loosen the four screws that hold the miter scale to the base (shown in Figure 9) and move the scale/miter arm assembly left or right until the blade is perpendicular to the fence, as measured with the square. Retighten the four screws. Pay no attention to the reading of the miter pointer at this point.

MITER POINTER ADJUSTMENT

Lift the miter adjustment/lock lever and move the miter arm to the zero position, as shown in Figure 7. With the miter adjustment/lock lever loose allow the miter latch to snap into place as you rotate the miter arm to zero. Observe the pointer and miter scale. If the pointer does not indicate exactly zero, loosen the screw that holds the pointer in place and gently move the pointer left or right. Retighten the screw after setting the pointer to zero.

MITER LOCK/DETENT ROD ADJUSTMENT

The miter lock/detent rod should be adjusted if the base of the saw can be moved when the miter adjustment/lock lever is locked-down.

To adjust the miter lock/detent rod, put the miter adjustment/lock lever in the up, unlocked position. Using a slotted screwdriver, tighten the lock rod by turning it clockwise (Figure 8). Turn the lock rod until it is tight, then turn counterclockwise 1/4 turn. To ensure the lock lever is functioning properly, re-lock the miter lock to a non-detented measurement on the miter scale—for example, 34°—and ensure the table will not rotate.

BEVEL STOPS AND POINTER ADJUSTMENT

Adjusting the bevel stop and pointer to 0°

Place the saw in the up position (0° bevel). Push head fully back (toward fence) and lock the rail lock knob. Place a square against the saw's base, fence and blade (Figure 11). (Do not touch the tips of the blade teeth with the square. To do so will cause an inaccurate measurement.) Loosen the bevel lock handle so bevel movement is snug, but not fully loose.

Push head of saw to the right (to contact the 0° bevel stop). The 0° bevel stop pin must be in its engaged position (Fig. 3A). Adjust the right bevel stop pin (Figure 12) until the blade is perpendicular to the base of the saw. Tighten the bevel lock handle securely. Make sure the bevel pointer indicates 0° exactly. If it does not, loosen the screw that holds the pointer in place, and gently move the pointer left or right. Retighten the screw after setting the pointer to 0°.

Adjusting the bevel stop to 45° left or right

NOTE: Adjust the 45° bevel angles only after performing the 0° bevel angle adjustment and with the 45° bevel stop pins engaged (Fig. 3A).

To adjust the left 45° bevel angle, loosen the bevel lock handle and tilt the head to the left until it is resting on the 45° bevel stop pin. If the pointer does not indicate exactly 45°, turn the left bevel stop pin until the pointer reads 45°.

To adjust the right 45° bevel angle, loosen the bevel lock handle and tilt the head to the right until it is resting on the 45° bevel stop pin. If the pointer does not indicate exactly 45°, turn the lower right bevel stop pin until the pointer indicates 45° (Figure 10).

FENCE ADJUSTMENT

Turn Off and Unplug the Miter Saw

To adjust the left or right fence, loosen the plastic knob shown in Figure 15 and slide the fence in or out. Always adjust the fence to be as close to the blade as practical to provide maximum workpiece support, without interfering with arm up & down movement or guard movement. Tighten knobs securely.

NOTE: When beveling to the right, it may be necessary to remove the right fence. To remove the fence, loosen the fence adjustment knob until the fence is free to slide off. ALWAYS make a trial run with the power off to ensure your saw will cut safely and properly.

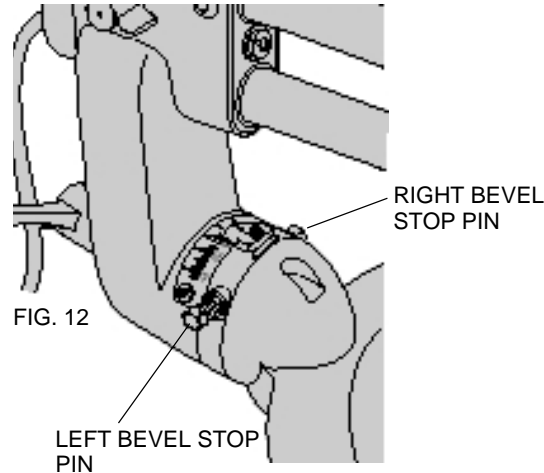

FIG. 12

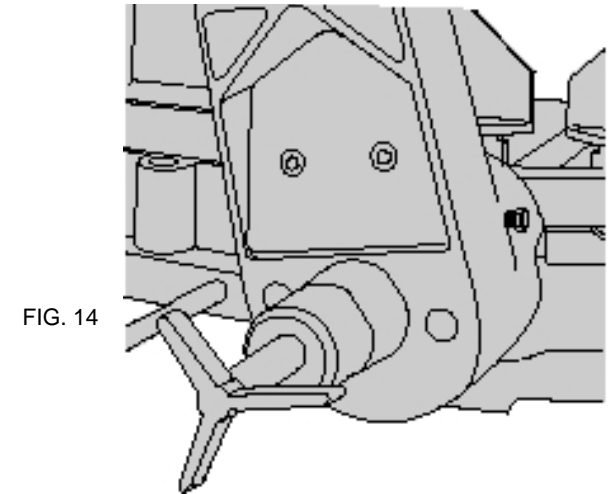

FIG. 14

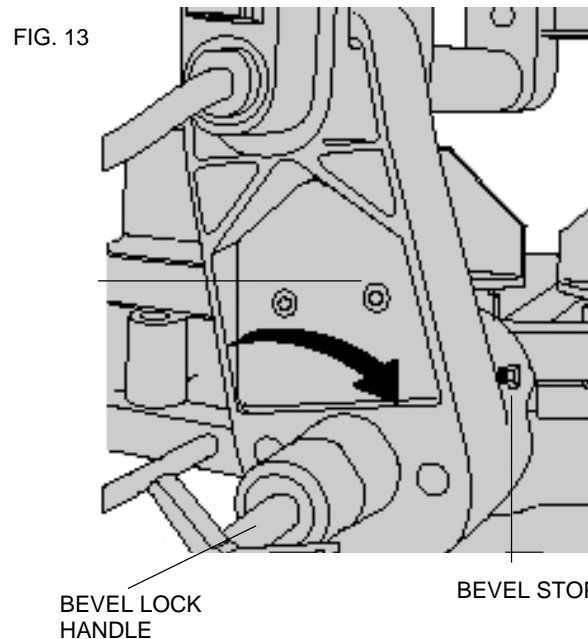

FIG. 13

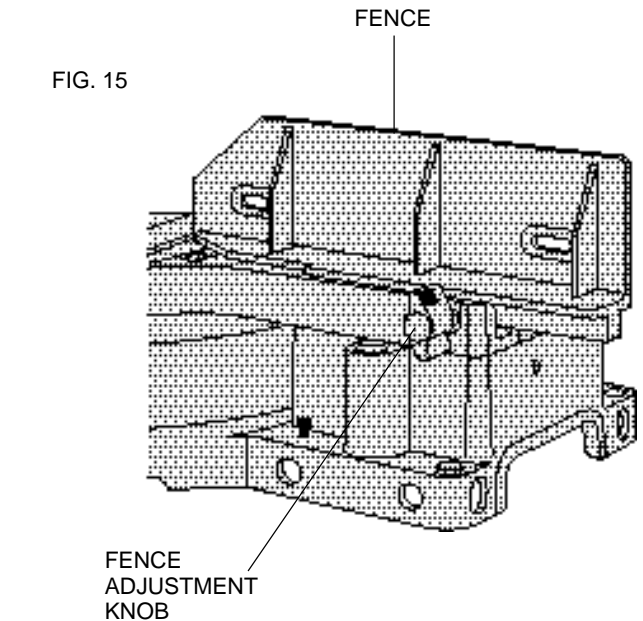

FIG. 15

FIG. 16

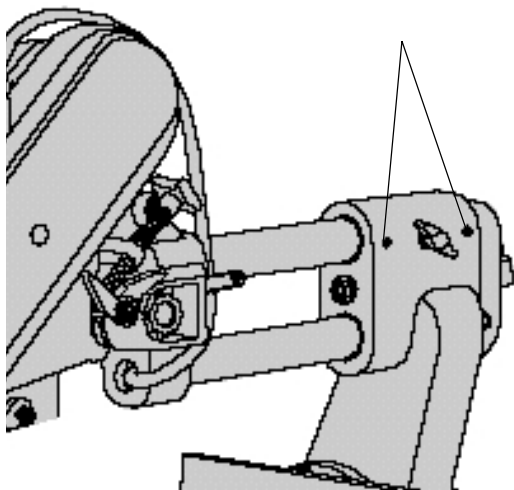
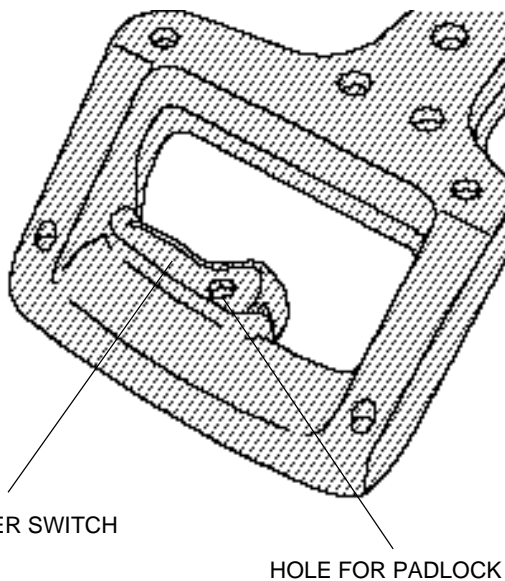

FIG. 17



TRIGGER SWITCH

HOLE FOR PADLOCK

GUARD ACTUATION AND VISIBILITY

The blade guard on your saw has been designed to automatically raise when the arm is brought down and to lower over the blade when the arm is raised.

The guard can be raised by hand when installing or removing saw blades or for inspection of the saw. **NEVER RAISE THE BLADE GUARD MANUALLY UNLESS THE SAW IS TURNED OFF.**

NOTE: Certain special cuts will require that you manually raise the guard.

The front section of the guard is louvered for visibility while cutting. Although the louvers dramatically reduce flying debris, they are openings in the guard and safety glasses should be worn at all times when viewing through the louvers.

AUTOMATIC ELECTRIC BRAKE

Your saw is equipped with an electric blade brake which stops the saw blade in approximately 3 seconds after trigger release. This is automatic and requires no adjustment.

Occasionally, under certain conditions, the brake will not function properly and won't stop the saw in the 3 seconds as discussed above. If this condition occurs, turn the saw on and off four or five times. If the brake still does not stop the blade in about 3 seconds, the problem may be worn brushes. Replace the brushes as described below and try the saw again. If the problem still persists, have the tool serviced at a Black & Decker service center or company authorized service facility.

RAIL GUIDE ADJUSTMENT

Periodically check the rails for any play or clearance. The top rail can be adjusted with the two right set screws shown in Figure 16. To reduce clearance, rotate the set screws clockwise gradually while sliding the saw head back and forth. Reduce play while maintaining minimum sliding force.

Brushes

DISCONNECT PLUG FROM POWER SUPPLY

Inspect carbon brushes regularly by unplugging tool, removing the brush inspection cap (Figure 2) and withdrawing the brush assembly. Keep brushes clean and sliding freely in their guides. Always replace a used brush in the same orientation in the holder as it was prior to its removal. Carbon brushes have varying symbols stamped into their sides, and if the brush is worn down to the line closest to the spring, they must be replaced. Use only identical DeWALT brushes. Use of the correct grade of brush is essential for proper operation of electric brake. New brush assemblies are available at Black & Decker service centers. The tool should be allowed to "run in" (run at no load) for 10 minutes before use to seat new brushes. The electric brake may be erratic in operation until the brushes are properly seated (worn in).

While "running in" **DO NOT TIE, TAPE, OR OTHERWISE LOCK THE TRIGGER SWITCH ON. HOLD BY HAND ONLY.**

Operation

Plug the saw into 60 Hz power source. Be sure the cord will not interfere with your work.

SWITCH

To turn the saw on, depress the trigger switch as shown in Figure 17. To turn the tool off, release the switch. There is no provision for locking the switch on, but a hole is provided in the trigger for insertion of a padlock to lock the saw off.

CUTTING WITH YOUR SAW

NOTE: Although this saw will cut wood and many non-ferrous materials, we will limit our discussion to the cutting of wood only. The same guidelines apply to the other materials. **DO NOT CUT FERROUS (IRON AND STEEL) MATERIALS OR MASONRY WITH THIS SAW.** Do not use any abrasive blades.

CROSSCUTS

A crosscut is made by cutting wood across the grain at any angle. A straight crosscut is made with the miter arm at the zero degree position. Set and lock the miter arm at zero, hold the wood firmly on the table and against the fence. With the rail lock knob tightened, turn on the saw by squeezing the trigger switch as shown in Figure 17.

When the saw comes up to speed (about 1 second) lower the arm smoothly and slowly to cut through the wood. Let the blade come to a full stop before raising arm.

When cutting anything larger than 2x4, use an out-down-back motion. Pull the saw out, toward you, lower the saw head down toward the workpiece, and push the saw back to complete the cut. Do not allow the saw to contact the top of the workpiece while pulling out. The saw may run toward you, causing personal injury or damage to the workpiece.

NOTE: The rail lock knob (Figure 3) must be loose to allow the saw to slide along its rails.

Miter crosscuts are made with the miter arm at some angle other than zero. This angle is often 45 degrees for making corners, but can be set anywhere from 50° left to 60° right. After selecting the desired miter angle, be sure to lock-down the miter adjustment/lock lever. Make the cut as described above.

NOTE: Cutting of multiple pieces is not recommended, but can be done safely by ensuring that each piece is held firmly against the table and fence.

BEVEL CUTS

A bevel cut is a crosscut made with the saw blade at a bevel to the wood. In order to set the bevel, unlock the bevel adjustment/lock lever and move the saw to the left or right as desired. Once the desired bevel angle has been set, lock the bevel adjustment/lock lever firmly.

The bevel stop pins (Figure 2) allow you to override built-in bevel stops at 0° and 45° left and right. See page 4 for more information.

Bevel angles can be set from 48° left to 48° right and can be cut with the miter arm set between 50° left and 60° right. Ensure the fence has been adjusted properly.

QUALITY OF CUT

The smoothness of any cut depends on a number of variables. Things like material being cut, blade type, blade sharpness and rate of cut all contribute to the quality of the cut.

When smoothest cuts are desired for molding and other precision work, a sharp (60 tooth carbide) blade and a slower, even cutting rate will produce the desired results.

To ensure that material does not creep while cutting, clamp it securely in place. Always let the blade come to a full stop before raising the arm. If small fibers of wood still split out at the rear of the workpiece, stick a piece of masking tape on the wood where the cut will be made. Saw through the tape and carefully remove tape when finished.

For varied cutting applications, refer to the list of recommended saw blades for your saw and select the one that best fits your needs.

BODY AND HAND POSITION (See Figure 18)

Proper positioning of your body and hands when operating the sliding compound miter saw will make cutting easier, more accurate and safer. Never place hands near cutting area. Place hands no closer than 6" (152mm) from the blade. Hold the workpiece tightly to the table and the fence when cutting. Keep hands in position until the trigger has been released and the blade has completely stopped. **ALWAYS MAKE DRY RUNS (UNPOWERED) BEFORE FINISH CUTS SO THAT YOU CAN CHECK THE PATH OF THE BLADE. DO NOT CROSS HANDS.**

Keep both feet firmly on the floor and maintain proper balance. As you move the miter arm left and right, follow it and stand slightly to the side of the saw blade. Sight through the guard louvers when following a pencil line.

CLAMPING THE WORKPIECE TURN OFF AND UNPLUG SAW

ALWAYS CLAMP WOOD TO THE SAW WHEN POSSIBLE. You can clamp to either side of the saw and remember to position your clamp against a solid, flat surface of the base. For best results use the DW7082 material clamp made for use with your saw. Available from your dealer at extra cost.

When cutting small pieces requiring your hand to be dangerously close (within 6" (152mm) to the saw blade, a clamp **MUST** be used to prevent loss of control. The left or right fence may be adjusted to aid clamping.

FIG. 18

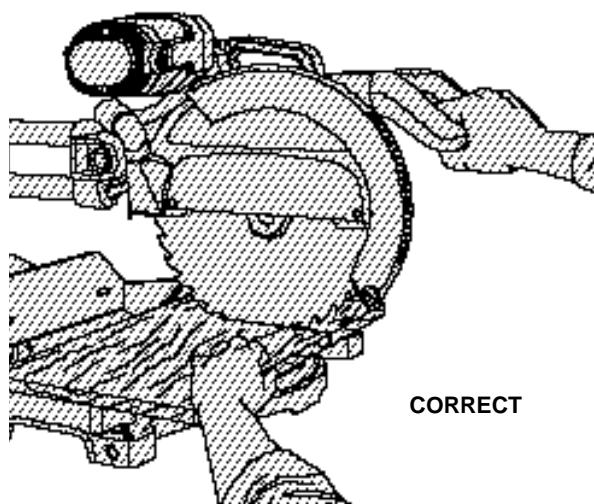

CORRECT

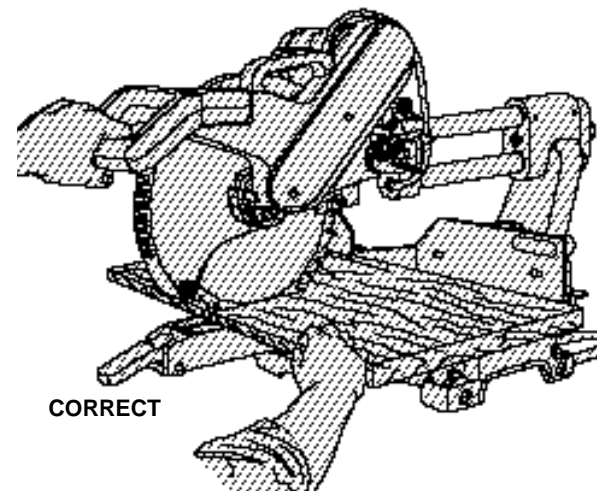

CORRECT

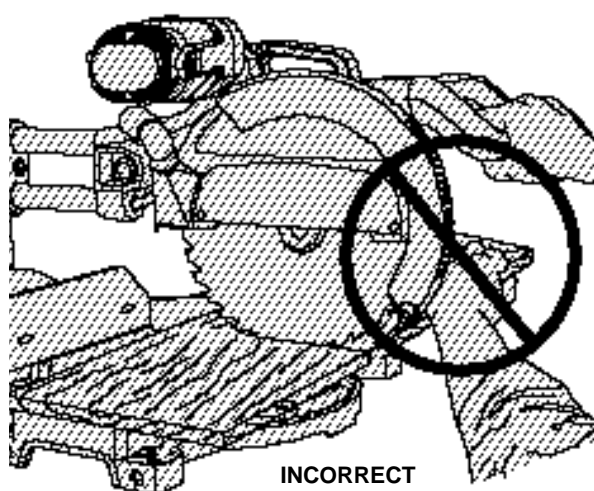

INCORRECT

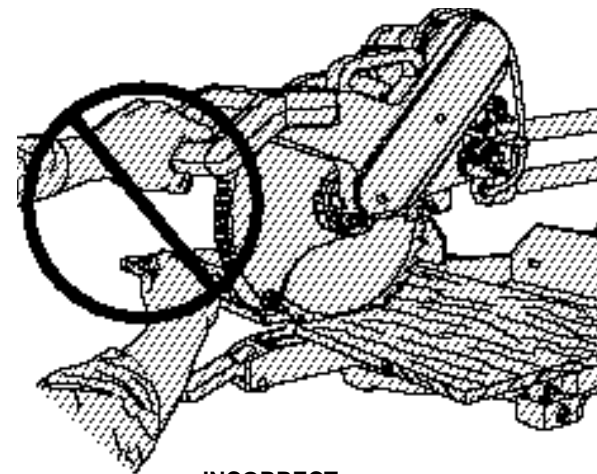

INCORRECT

SUPPORT FOR LONG PIECES

Turn Off and Unplug Saw

ALWAYS SUPPORT LONG PIECES

For best results, use the DW7080 extension kit to extend the table width of your saw. Available from your dealer at extra cost. Support long workpieces using any convenient means such as sawhorses or similar devices to keep the ends from dropping. The base top is 3.5" tall, allowing a 4x4 or 2 2x4s to be used on a long table or bench.

CUTTING PICTURE FRAMES, SHADOW BOXES AND OTHER FOUR SIDED PROJECTS

To best understand how to make the items listed here, we suggest that you try a few simple projects using scrap wood until you develop a FEEL for your saw.

Your saw is the perfect tool for mitering corners like the one shown in Figure 19. Sketch A in Figure 19 shows a joint made by using the bevel adjustment to bevel the edges of the two boards at 45 degrees each to produce a 90 degree corner. For this joint the miter arm was locked in the zero position and the bevel adjustment was locked at 45 degrees. The wood was positioned with the broad flat side against the table and the narrow edge against the fence.

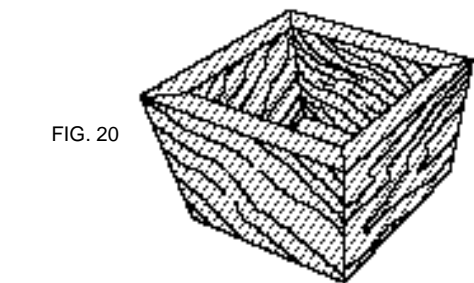

The cut could also be made by mitering right and left with the broad surface against the fence.

CUTTING TRIM MOLDING AND OTHER FRAMES

Sketch B in Figure 19 shows a joint made by setting the miter arm at 45 degrees to miter the two boards to form a 90 degree corner. To make this type of joint, set the bevel adjustment to zero and the miter arm to 45 degrees. Once again, position the wood with the broad flat side on the table and the narrow edge against the fence.

The two sketches in Figure 19 are for four sided objects only.

As the number of sides changes, so do the miter and bevel angles. The following chart gives the proper angles for a variety of shapes.

(The chart assumes that all sides are of equal length.) For a shape that is not shown in the chart, use the following formula. 180 degrees divided by the number of sides equals the miter or bevel angle.

- EXAMPLES -

| NO. SIDES | ANGLE MITER OR BEVEL |
|-----------|----------------------|
| 4 | 45° |
| 5 | 36° |
| 6 | 30° |
| 7 | 25.7° |

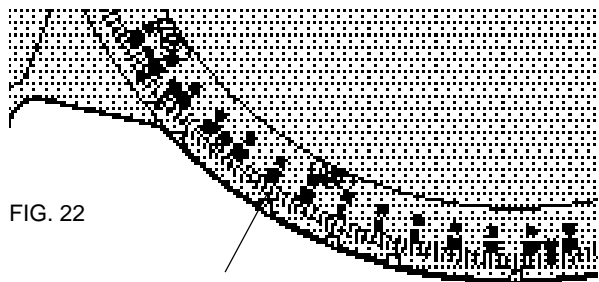

FIG. 22
DUAL RANGE MITER SCALE

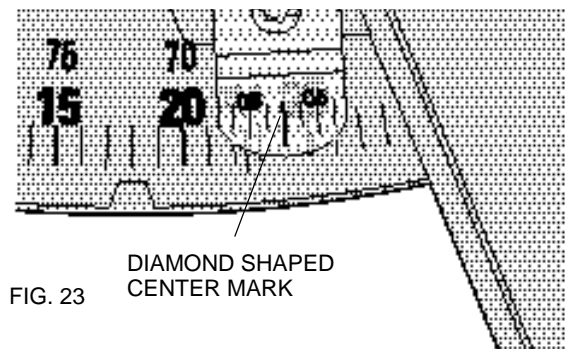

FIG. 23
DIAMOND SHAPED CENTER MARK

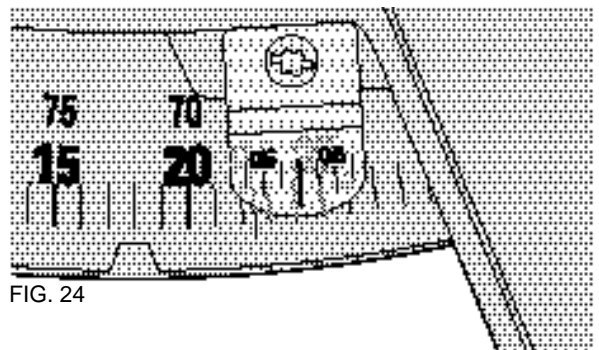

FIG. 24

| | |
|----|-------|
| 8 | 22.5° |
| 9 | 20° |
| 10 | 18° |

CUTTING COMPOUND MITERS

A compound miter is a cut made using a miter angle and a bevel angle at the same time. This is the type of cut used to make frames or boxes with slanting sides like the one shown in Figure 20.

NOTE: If the cutting angle varies from cut to cut, check that the bevel adjustment/lock lever and the miter adjustment/lock lever are securely tightened. These levers

must be tightened and locked after making any changes in bevel or miter.

The chart shown on page 14 will assist you in selecting the proper bevel and miter settings for common compound miter cuts. To use the chart, select the desired angle "A" (Figure 21) of your project and locate that angle on the appropriate arc in the chart. From that point follow the chart straight down to find the correct bevel angle and straight across to find the correct miter angle.

Set your saw to the prescribed angles and make a few trial cuts. Practice fitting the cut pieces together until you develop a feel for this procedure and feel comfortable with it.

Example: To make a 4 sided box with 25° exterior angles (Angle A, Figure 21), use the upper right arc. Find 25° on the arc scale. Follow the horizontal intersecting line to either side to get miter angle setting on saw (23°). Likewise, follow the vertical intersecting line to the top or bottom to get the bevel angle setting on the saw (40°). Always try cuts on a few scrap pieces of wood to verify settings on saw.

DUAL RANGE MITER SCALE

The miter scale has two ranges of numbers for convenience, as shown in Figure 22. One scale indicates 0 degrees when the blade is square to the fence. At this position the other scale reads 90 degrees.

The 0 degree scale (larger numbers closer to the front edge) is used when calculating angles. To calculate the proper miter angle, divide 180 degrees by the number of sides of the box or frame.

The 90 degree scale (smaller numbers behind the zero degree scale) is used when a corner of your box or frame is measured with a protractor. For example: if you measure the corner of an 8 sided box, the protractor will read 135 degrees. To determine the proper miter setting, divide the measured angle by two. The proper miter setting in this example is 67-1/2 degrees. Set this angle on the 90 degree scale. This is most useful when a corner is at an odd angle.

VERNIER SCALE

Your saw is equipped with a vernier scale for added precision. The vernier scale allows you to accurately set miter angles to the nearest 1/4 degree (15 minutes). To use the vernier scale follow the steps listed below.

(As an example, assume that the angle you want to miter is 24-1/4 degree right).

1. Turn off sliding compound miter saw.
2. Set the miter angle to the nearest whole degree desired by aligning the diamond-shaped center mark in the vernier scale, shown in Figure 23, with the whole degree number etched in the miter scale. Examine Figure 24 closely; the setting shown is 24 degrees right miter.
3. To set the additional 1/4 degree, move the first mark on the RIGHT of the diamond to the RIGHT until the 1/4 degree vernier mark aligns with the CLOSEST degree

mark on the miter scale. In our example, the closest degree mark on the miter scale happens to be 25 degrees. Figure 24 shows a setting of 24-1/4 degrees right miter.

- To set a 1/2 degree, align the second mark on the scale (marked 0.5) with the nearest whole degree number. For example, to miter 24-1/2 degrees to the right, move the SECOND mark on the RIGHT of the diamond to the RIGHT until the 1/2 degree vernier mark aligns with the CLOSEST degree mark on the miter scale.
- To set a 3/4 degree, align the THIRD mark on the scale with the nearest whole degree number. For example, to miter 24-3/4 degrees to the right, move the THIRD mark on the RIGHT of the diamond to the RIGHT until the 3/4 degree vernier mark aligns with the CLOSEST degree mark on the miter scale.

WHEN MITERING TO THE RIGHT

To increase the miter angle when mitering to the right, move the arm to align the appropriate vernier mark with the closest mark on the miter scale to the right. To decrease the miter angle when mitering to the right, move the arm to align the appropriate vernier mark with the closest mark on the miter scale to the left.

WHEN MITERING TO THE LEFT

To increase the miter angle when mitering to the left, move the arm to align the appropriate vernier mark with the closest mark on the miter scale to the left. To decrease the miter angle when mitering to the left, move the arm to align the appropriate vernier mark with the closest mark on the miter scale to the right.

CUTTING BASE MOLDING

ALWAYS MAKE A DRY RUN WITHOUT POWER BEFORE MAKING ANY CUTS.

Straight 90 degree cuts –

Position the wood against the fence and hold it tightly to the fence and table, as shown in Figure 25. Turn on the saw, allow the blade to reach full speed and lower the arm smoothly through the cut.

CUTTING BASE MOLDING UP TO 4-1/4" (108 mm) HIGH VERTICALLY AGAINST THE FENCE

Position molding as shown in Figure 26.

All cuts made with the back of the molding against the fence and bottom of the molding against the base.

INSIDE CORNER:

Left side

- Miter left 45°
- Save left side of cut

Right side

- Miter Right 45°
- Save right side of cut

OUTSIDE CORNER:

FIG. 25

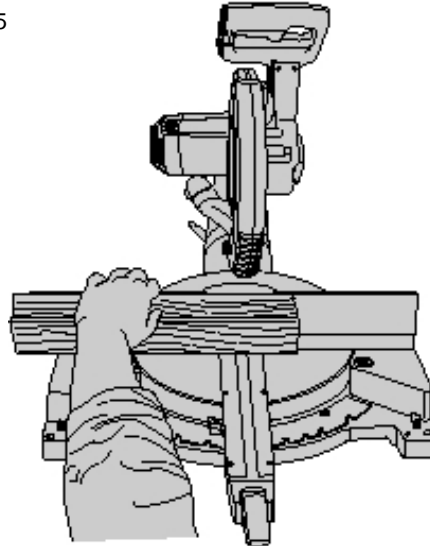

FIG. 27

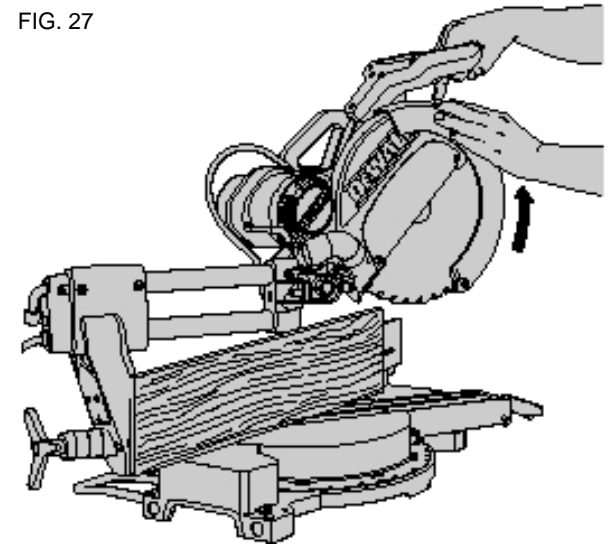

FIG. 26

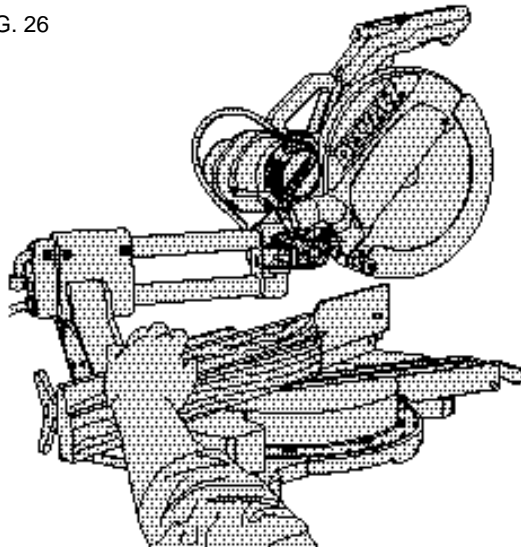
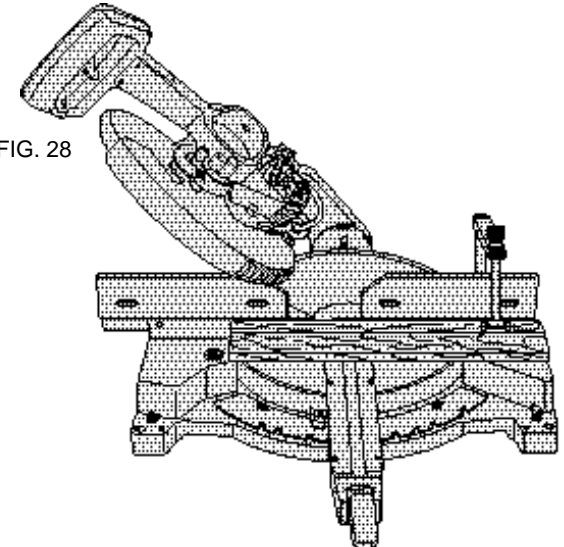
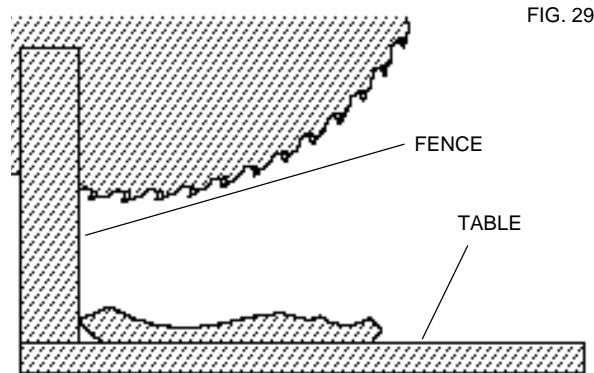
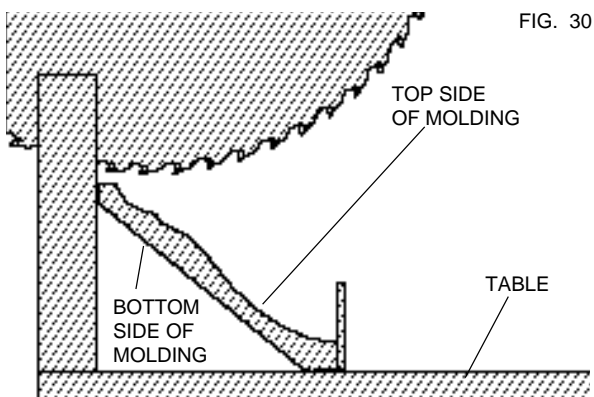

FIG. 28





CROWN MOLDING FLAT ON TABLE AND AGAINST FENCE



CROWN MOLDING BETWEEN FENCE AND TABLE

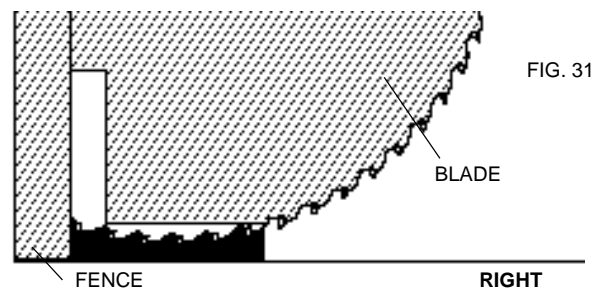

FIG. 29

Left side

1. Miter right at 45°
2. Save left side of cut

Right side

1. Miter left at 45°
2. Save right side of cut

Material up to 4.25" (108mm) can be cut as described above. For wider boards [up to 5.25" (133mm)] several minor concessions must be made.

When cutting a board between 4.25" (108mm) and 5.25" (133mm) in width the roller on the tip of the guard will hang up on the workpiece. If this occurs, roll the guard up just enough to clear the workpiece, as shown in Figure 27. Once you have cleared the workpiece, you can release the guard and it will continue to open as the cut progresses. Hold the workpiece securely against the fence and base before starting the cut.

When mitering to the right side of a base molding wider than 3.9" (99mm) standing vertically against the fence as in Figure 27, the saw can only cut through the board up to 1 inch from the end of the board. Trying to cut more than an inch will cause the saw's gear case to interfere with the workpiece. If you want to cut base molding between 4-1/4" (108mm) and 5-1/4" (133mm) wide vertically follow the directions below.

CUTTING 4-1/4"– 5-1/4" (108mm-133mm) BASE MOLDING VERTICALLY AGAINST THE FENCE

- Position molding as shown in Figure 26.
- All cuts made with the back of the molding against the fence

INSIDE CORNER:

Left side

1. Position molding with bottom of molding against the base of the saw
2. Miter left 45°
3. Save left side of cut

Right side

1. Position molding with top of the molding resting on the base of the saw
2. Miter left 45°
3. Save left side of cut

OUTSIDE CORNER:

Left side

1. Position molding with bottom of molding against the base of the saw
2. Miter right 45°
3. Save left side of cut

NOTE: If the cut must be made somewhere other than 1" (25.4mm) from the end of the molding: cut off the molding at 90° approx. 1" (25.4mm) longer than your final length then make the miter cut as described above.

Right side

1. Position molding with bottom of the molding against the base of the saw
2. Miter left 45°
3. Save the right side of cut

A third method of making the cut necessary for sketch A is to make a zero degree miter, 45 degree bevel cut. Your saw can cut a bevel 12" (305mm) wide.

CUTTING BASE MOLDING LAYING FLAT AND USING THE BEVEL FEATURE

- All cuts made with the saw set at 45° bevel and 0 miter
- All cuts made with back of molding laying flat on the saw and the bottom of the molding against the fence, as shown in Figure 28.

INSIDE CORNER:

Left side

1. Bevel 45° right
2. Save right side of cut

Right side

1. Bevel 45° left
2. Save left side of cut

OUTSIDE CORNER:

Left side

1. Bevel 45° left
2. Save right side of cut

Right side

1. Bevel 45° right
2. Save left side of cut

CUTTING CROWN MOLDING

To fit properly, crown molding must be cut with extreme accuracy.

The two flat surfaces on a given piece of crown molding are at angles that, when added together, equal exactly 90 degrees. Most, but not all, crown molding has a top rear angle (the section that fits flat against the ceiling) of 52 degrees and a bottom rear angle (the part that fits flat against the wall) of 38 degrees.

Your sliding compound miter saw has special pre-set miter latch points at 31.6 degrees left and right for cutting crown molding flat at the proper angle. There is also a mark on the bevel scale at 33.9 degrees.

The chart on the next page gives the proper settings for cutting crown molding. (The numbers for the miter and bevel settings are very precise and are not easy to accurately set on your saw.) Since most rooms do not have angles of precisely 90 degrees, you will have to fine tune your settings anyway.

TABLE 1 COMPOUND MITER CUT (POSITION WOOD WITH BROAD FLAT SIDE ON THE TABLE AND THE NARROW EDGE AGAINST THE FENCE)

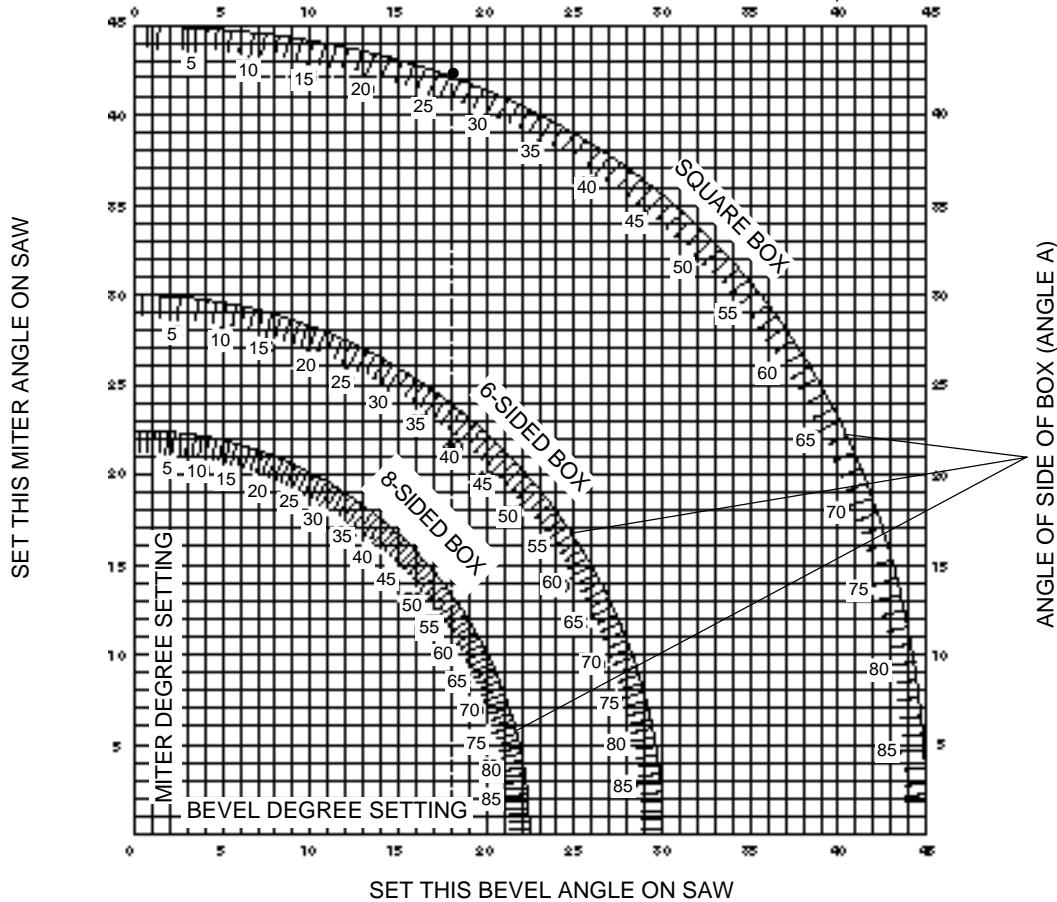

INSTRUCTIONS FOR CUTTING CROWN MOLDING LAYING FLAT AND USING THE COMPOUND FEATURES

1. Molding laying with broad back surface down flat on saw table (See Figure 26)
2. The settings below are for All Standard (U.S.) crown molding with 52° and 38° angles.

| BEVEL SETTING | TYPE OF CUT |
|---------------|---------------------------------|
| Left 33.9° | LEFT SIDE, INSIDE CORNER: |
| | 1. Top of molding against fence |
| | 2. Miter table set right 31.62° |
| Right 33.9° | RIGHT SIDE, INSIDE CORNER: |
| | 1. Top of molding against fence |
| | 2. Miter table set left 31.62° |
| Right 33.9° | LEFT SIDE, OUTSIDE CORNER: |
| | 1. Top of molding against fence |
| | 2. Miter table set left 31.62° |
| Left 33.9° | RIGHT SIDE, OUTSIDE CORNER: |
| | 1. Top of molding against fence |
| | 2. Miter table set right 31.62° |

When setting bevel and miter angles for all compound miters, remember that:

The angles presented for crown moldings are very precise and difficult to set exactly. Since they can easily shift slightly and very few rooms have exactly square corners, all settings should be tested on scrap molding.

PRETESTING WITH SCRAP MATERIAL IS EXTREMELY IMPORTANT!

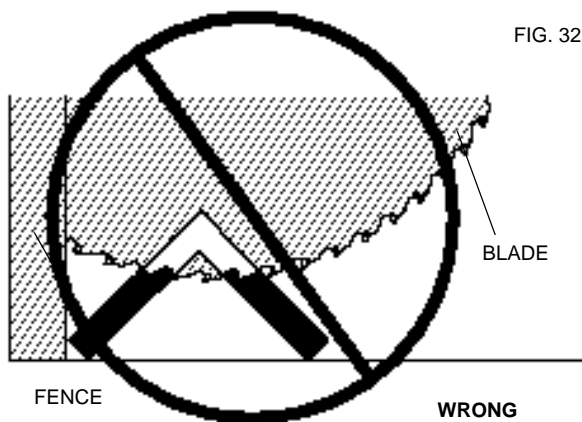

FIG. 32

PRETESTING WITH SCRAP MATERIAL IS EXTREMELY IMPORTANT!

METHOD FOR CUTTING CROWN MOLDING ANGLED BETWEEN THE FENCE AND TABLE

Place the molding on the table at an angle between the fence and the saw table, as shown in Figure 29. Use of the crown molding fence accessory (DW7054) is highly recommended because of its degree of accuracy and convenience. The crown molding fence accessory is available at extra cost from your local dealer.

The advantage to cutting crown molding using this method is that no bevel cut is required. Minute changes in the miter angle can be made without affecting the bevel angle. This way, when corners other than 90 degrees are encountered, the saw can be quickly and easily adjusted for them. Use the crown molding fence accessory to maintain the angle at which the molding will be on the wall.

INSTRUCTIONS FOR CUTTING CROWN MOLDING ANGLED BETWEEN THE FENCE AND BASE OF THE SAW FOR ALL CUTS:

1. Angle the molding so the bottom of the molding (part which goes against the wall when installed) is against the fence and the top of the molding is resting on the base of the saw, as shown in Figure 30.
2. The angled "flats" on the back of the molding must rest squarely on the fence and base of the saw.

INSIDE CORNER:

Left side

1. Miter right at 45°
 2. Save the right side of cut
- Right side

1. Miter left at 45°

2. Save left side of cut

OUTSIDE CORNER:

Left side

1. Miter left at 45°
2. Save right side of cut

Right side

1. Miter right at 45°
2. Save left side of cut

SPECIAL CUTS

NEVER MAKE ANY CUT WITHOUT FIRMLY CLAMPING THE MATERIAL.

Aluminum Cutting:

Aluminum extrusions such as those used when making aluminum screens and storm windows can easily be cut with your saw. Position the material so that you will be cutting the thinnest cross section, as shown in Figure 31. Figure 32 illustrates the wrong way to cut these extrusions. Use a wax lubricant when cutting aluminum such as Johnson's Stick Wax No. 140. Apply the stick wax directly to the saw blade before cutting. Never apply stick wax to a

moving blade.

The wax, available at most hardware stores and industrial mill supply houses, provides proper lubrication and keeps chips from adhering to the blade.

Bowed Material:

When cutting bowed material always position it as shown in Figure 33 and never like that shown in Figure 34. Positioning the material incorrectly will cause it to pinch the blade near the completion of the cut.

Cutting Plastic Pipe and Other Round Cross-Sectional Material

Plastic pipe and similar material can be easily cut with your saw. It should be cut just like wood and **CLAMPED OR HELD FIRMLY TO THE FENCE TO KEEP IT FROM ROLLING PARTICULARLY WHEN CUTTING ANGLES.**

Cutting Large Material

Occasionally you will encounter a piece of wood a little too large to fit beneath the blade guard. A little extra height can be gained by rolling the guard up out of the way, as shown in Figure 27. Avoid doing this as much as possible, but if need be, the saw will operate properly and make the bigger cut. **NEVER TIE, TAPE, OR OTHERWISE HOLD THE GUARD OPEN WHEN OPERATING THIS SAW.**

GROOVING

Your sliding compound miter saw is equipped with a grooving lever and thumbscrew to allow for groove cutting.

To use the grooving feature, flip the grooving lever toward the front of the saw, as shown in Figure 35.

Adjust the thumbscrew to change the depth of the groove cut. **ALWAYS MAKE DRY RUNS (UNPOWERED) BEFORE FINISH CUTS SO THAT YOU CAN CHECK THE DEPTH OF THE BLADE.**

NOTE: Your saw is not designed for use with dado blades.

Installing a New Saw Blade

UNPLUG THE SLIDING COMPOUND MITER SAW

DO NOT CUT FERROUS METAL (THAT WITH AN IRON OR STEEL CONTENT) OR MASONRY WITH THIS SLIDING COMPOUND MITER SAW.

Before installing or removing a blade, always lock the miter adjustment/lock lever, lock the rail lock knob, and lock the bevel adjustment/lock lever.

- 1) Loosen the arbor cover screw, and pivot the arbor cover up, as shown in Figure 36. **NOTE:** This screw is a specific length to provide a caliper for the blade to prevent guard damage. Do not replace this screw with a different screw.
- 2) While holding the spindle lock, use the supplied blade wrench to loosen (clockwise) the left hand threaded blade screw.

NOTE: To use the spindle lock (Figure 37), depress the button as shown and rotate the blade by hand until you

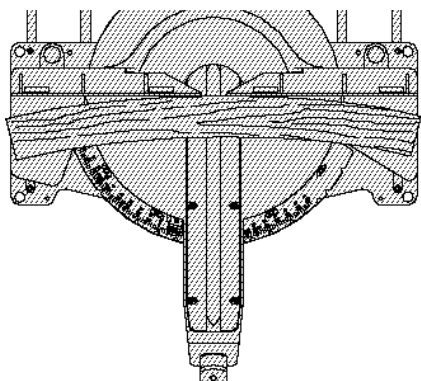

FIG. 33

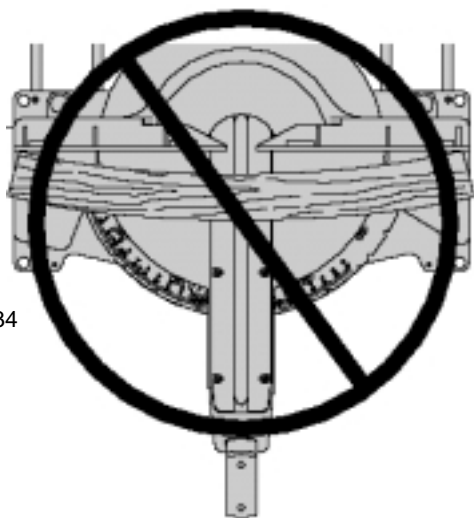

FIG. 34

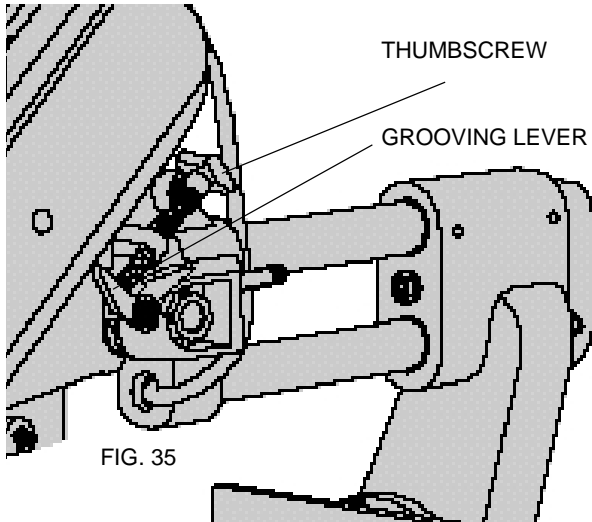

FIG. 35

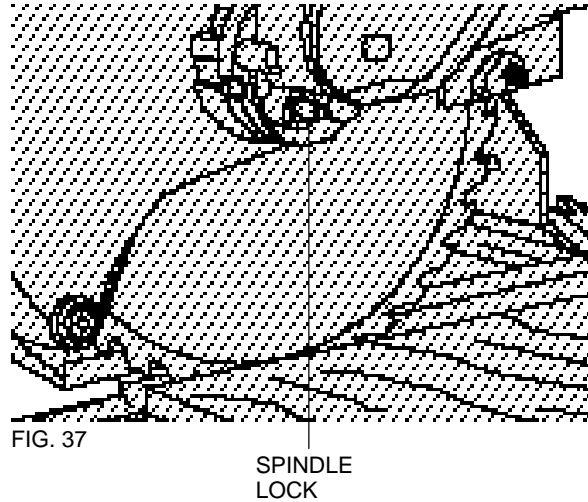

FIG. 37

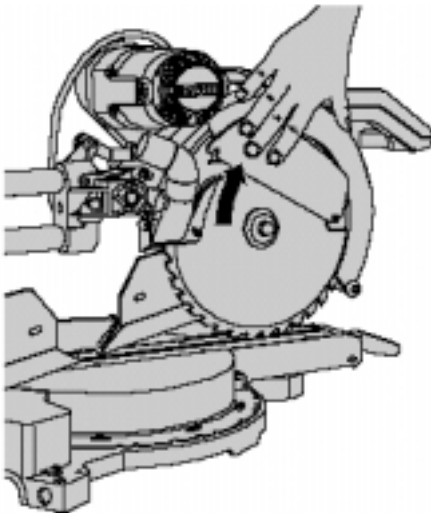

FIG. 36

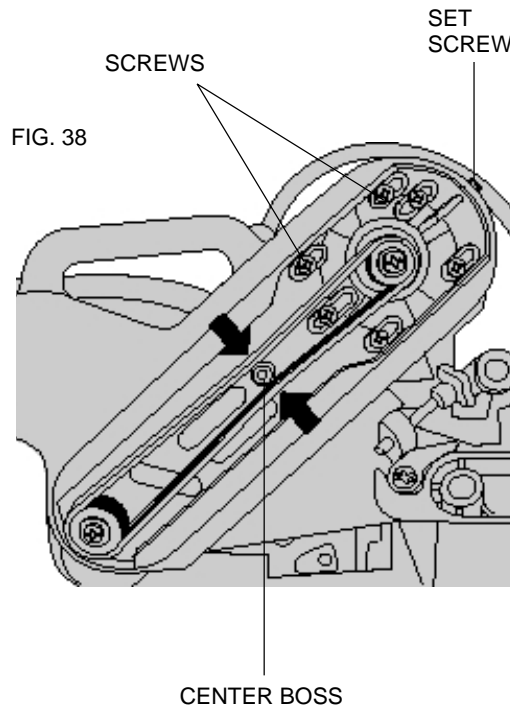

FIG. 38

feel the lock engage. Continue to hold the lock button in to keep the spindle from turning.

3) Using the blade wrench, remove the blade screw and carefully remove the blade.

The inner clamp washer is installed first, then the blade adapter. The blade adapter is designed to permit the use of saw blades with 1" (25.4mm) arbor holes as well as those with 5/8" (15.8mm) arbor holes.

When using blades with 1" (25.4mm) arbor holes, install the blade adapter over the spindle shaft and against the inner clamp washer. Next, install the saw blade making sure that the arbor hole in the blade fits on the blade adapter. Make sure that the teeth at the bottom of the blade are pointing toward the back of the saw (away from the operator). Install the outer clamp washer and install the blade screw. Tighten firmly using the spindle lock and the provided wrench (left hand threads). When using saw blades with 5/8" (15.8mm) arbor holes, remove the blade adapter! Save it in a safe place for future use. The rest of the blade assembly is exactly the same.

REPLACE AND SECURE ARBOR COVER TO PREVENT BLADE SCREW AND BLADE SEPARATION FROM SPINDLE SHAFT.

NEVER DEPRESS THE SPINDLE LOCK PIN WHILE THE BLADE IS ROTATING.

Removing and Replacing Belt

The belt is designed to last the life of the tool. However, abuse of the tool could cause the belt to fail.

If the blade does not turn when the motor is running, the belt has failed. To inspect or replace the belt, remove the belt cover screw. Remove the belt cover. Inspect the ribs of the belt for wear or failure. Check belt tension by squeezing the belt as shown in Figure 38. The belt should contact the center boss with medium pressure.

To adjust the tension, loosen, but do not remove, the six Phillips head screws (Figure 38). Then rotate the set screw on the top of the motor plate casting until the proper tension is achieved. Tighten the six screws securely and replace the belt cover. **NOTE:** Overtightening the belt will cause premature motor failure.

Maintenance

1. All bearings are sealed ball bearings. They are lubricated for life and need no further maintenance. Do not use WD-40 or any other lubricant.
2. Periodically clean all dust and wood chips from around the area of the saw. Even though slots are provided to allow debris to pass through, some dust will accumulate.
3. The brushes are designed to give you several years of use. If they ever need replacement follow the instructions on page 9 or return the tool to the nearest service center for repair. Service center locations are

packed with your tool.

Important

To assure product SAFETY and RELIABILITY, repairs, maintenance and adjustment (including brush inspection and replacement) should be performed by authorized service centers or other qualified service organizations, always using identical replacement parts.

Black & Decker (U.S.) Inc. industrial tool service centers are certified for servicing DeWALT industrial tools.

Full Warranty

DeWALT heavy duty industrial tools are warranted for one year from date of purchase. We will repair, without charge, any defects due to faulty materials or workmanship. Please return the complete unit to any DeWALT certified service center. This warranty does not apply to accessories or damage caused where repairs have been made or attempted by others.

In addition to the warranty, DeWALT tools are covered by our:

30 DAY NO RISK SATISFACTION GUARANTEE

If you are not completely satisfied with the performance of this tool within 30 days of purchase simply return it to your place of purchase to replace it with a new identical tool.



See 'Tools-Electric'
-Yellow Pages-
for Service & Sales

Trouble Shooting Guide

BE SURE TO FOLLOW SAFETY RULES AND INSTRUCTIONS

TROUBLE! SAW WILL NOT START

WHAT'S WRONG?

1. Saw not plugged in
2. Fuse blown or circuit breaker tripped
3. Cord damaged
4. Brushes worn out

WHAT TO DO...

1. Plug in saw.
2. Replace fuse or reset circuit breaker
3. Have cord replaced by authorized service center
4. Have brushes replaced by authorized service center.

TROUBLE! SAW MAKES UNSATISFACTORY CUTS

WHAT'S WRONG?

1. Dull blade
2. Blade mounted backwards
3. Gum or pitch on blade
4. Incorrect blade for work being done

WHAT TO DO...

1. Replace blade. See page 15.
2. Turn blade around. See page 15
3. Remove blade and clean with turpentine and coarse steel wool or household oven cleaner.
4. Change the blade. See page 15.

TROUBLE! BLADE DOES NOT COME UP TO SPEED

WHAT'S WRONG?

1. Extension cord too light or too long
2. Low house current

WHAT TO DO...

1. Replace with adequate size cord. See page 2.
2. Contact your electric company

TROUBLE! MACHINE VIBRATES EXCESSIVELY

WHAT'S WRONG?

1. Saw not mounted securely to stand or work bench
2. Stand or bench on uneven floor
3. Damaged saw blade

WHAT TO DO...

1. Tighten all mounting hardware. See page 6.
2. Reposition on flat level surface. See page 6.
3. Replace blade. See page 15.

TROUBLE! DOES NOT MAKE ACCURATE MITER CUTS

WHAT'S WRONG?

1. Miter scale not adjusted correctly
2. Blade is not square to fence
3. Blade is not perpendicular to table
4. Workpiece moving

WHAT TO DO...

1. Check and adjust. See page 7.
2. Check and adjust. See page 7.
3. Check and adjust fence. See page 8.
4. Clamp workpiece to fence or glue 120 grit sandpaper to fence with rubber cement.

TROUBLE! MATERIAL PINCHES BLADE

WHAT'S WRONG?

1. Cutting bowed material

WHAT TO DO...

1. Position bowed material as shown on page 15.