

DEWALT®



Instruction Manual

DW12A-01T9739
DW12AVP2R3739
Self-Propelled Mower

www.DEWALT.com

If you have questions or comments, contact us.

1-855-971-1123



Form No. 769-26879
(November 21, 2023)

English (***original instructions***)

3





Spanish (*Español*)

19

SAFE OPERATION PRACTICES

Definitions: Safety Alert Symbols and Words

This instruction manual uses the following safety alert symbols and words to alert you to hazardous situations and your risk of personal injury or property damage.

-  **DANGER:** Indicates an imminently hazardous situation which, if not avoided, will result in death or serious injury.
 -  **WARNING:** Indicates a potentially hazardous situation which, if not avoided, could result in death or serious injury.
 -  **CAUTION:** Indicates a potentially hazardous situation which, if not avoided, may result in minor or moderate injury.
 -  (Used without word) Indicates a safety related message.
- NOTICE:** Indicates a practice **not related to personal injury** which, if not avoided, **may** result in property damage.
-

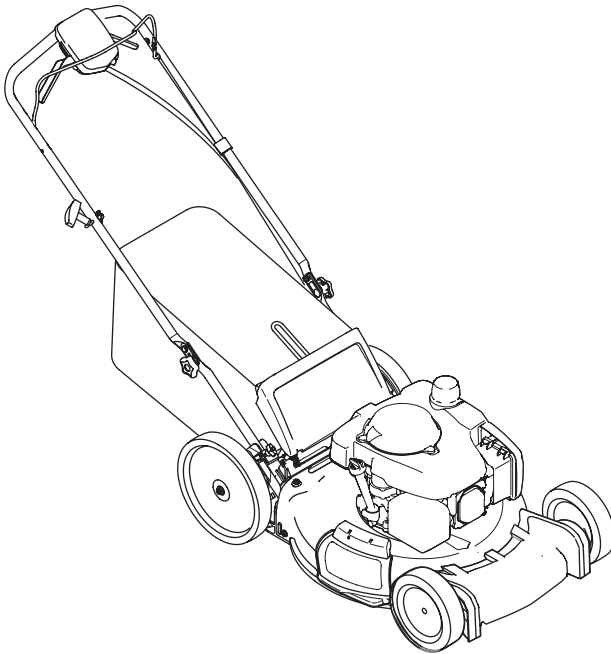

 **WARNING!** Read all safety warnings and all instructions. Failure to follow the warnings and instructions may result in electric shock, fire, and/or serious injury.

NOTE: This Operator's Manual covers several models. Features may vary by model. Not all features in this manual are applicable to all models and the model depicted may differ from yours.

If you have any questions or comments about this or any DeWALT tool, call us toll free at: 1-855-971-1123.

SAFE OPERATION PRACTICES



WARNING:  This symbol points out important safety instructions which, if not followed, could endanger the personal safety and/or property of yourself and others. Read and follow all instructions in this manual before attempting to operate this machine. Failure to comply with these instructions may result in personal injury. When you see this symbol. **HEED ITS WARNING!**



DANGER: This machine was built to be operated according to the safe operation practices in this manual. As with any type of power equipment, carelessness or error on the part of the operator can result in serious injury. This machine is capable of amputating hands and feet and throwing objects. Failure to observe the following safety instructions could result in serious injury or death.

General Information

1. Read, understand, and follow all instructions on the mower and in the manual(s) before attempting to assemble and operate. Keep this manual in a safe place for future and regular reference and for ordering replacement parts.
2. Be familiar with all controls and their proper operation.
3. Never allow children under 14 years of age to operate this mower. Children 14 and over should read and understand the instructions and safe operation practices in this manual and on the mower and should be trained and supervised by an adult.
4. Never allow adults to operate this mower without proper instruction.
5. Store mower in a dry, clean area. Do not store next to corrosive materials, such as fertilizer.
6. If situations occur which are not covered in this manual, use care and good judgment. Contact your customer service representative for assistance.
7. According to the U.S. Consumer Products Safety Commission (CPSC) and the U.S. Environmental Protection Agency (EPA), this product has an estimated useful life of seven (7) years, under ordinary use conditions. At the end of its useful life, have the product inspected annually to ensure all mechanical and safety systems are operating properly, safely, and are not worn excessively. Failure to do so may result in accident, injury, or death.

Preparation Before Operating

1. Thoroughly inspect the area where the mower is to be used. Remove all stones, sticks, wire, bones, toys, and other foreign objects which could be tripped over or picked up and thrown by the blade(s). Thrown objects can cause serious personal injury.
2. To help avoid blade contact or a thrown object injury, stay in the operator zone behind the mower handles. Keep helpers at least 75 feet (23 meters) from the mower while it is in operation. Keep bystanders, children and pets inside while the mower is in operation. Stop mower if anyone enters the area.
3. Be aware of the mower and attachment discharge direction and do not point the mower discharge at anyone.
4. Always wear safety glasses or safety goggles during operation and while performing an adjustment or repair to protect your eyes. Thrown objects which ricochet can cause serious injury to the eyes.
5. Wear sturdy, rough-soled work shoes and close-fitting slacks and shirts. Loose fitting clothes, jewelry and long hair can be caught in moving parts. Shirts and pants that cover the arms and legs and steel-toed shoes are recommended.
6. Never operate mower in bare feet, sandals, slippery or light-weight (e.g. canvas) shoes.
7. Never over fill fuel tank. Fill tank to no more than 1" (2.5 cm) below bottom of filler neck to allow space for fuel expansion.
8. Replace gasoline cap and tighten securely.
9. Use only accessories and attachments approved for this mower by the mower manufacturer. Read, understand and follow all instructions provided with the approved accessory or attachment.

Operating

1. Data indicates that operators, age 65 years and above, are involved in a large percentage of mower-related injuries. These operators should evaluate their ability to operate the mower safely enough to protect themselves and others from serious injury.
2. Many injuries occur as a result of the mower being pulled over the foot during a fall caused by slipping or tripping. Do not hold on to the mower if you are losing your balance or footing; immediately release the handle.
3. Never pull the mower back toward you while you are walking. If you must back the mower away from a wall or obstruction first look down and behind to avoid tripping and then follow these steps:
 - a. Step back from mower to fully extend your arms.
 - b. Be sure you are well balanced with sure footing.

SAFE OPERATION PRACTICES, cont'd

- c. Pull the mower back slowly, no more than half way toward you.
- d. Repeat these steps as needed.
4. Do not engage the drive control (if equipped) while starting engine.
5. The blade control is a safety device. Never attempt to bypass its operation. Doing so makes the safety device inoperative and may result in personal injury through contact with the rotating blade. The blade control must operate freely in both directions and automatically return to the disengaged (off) position when released. The cutting blade continues to rotate for up to three seconds after the blade control is released. Never place any part of the body in the blade area until you are certain the blade has stopped rotating.
6. If the mower should start to vibrate abnormally, stop the engine and check immediately for the cause. Vibration is generally a warning of trouble.
7. Never operate mower without the proper trail shield, discharge cover, grass catcher, blade control or other safety protective devices in place and working. Never operate mower with damaged safety devices. Failure to do so can result in personal injury.
8. When starting engine, pull cord slowly until resistance is felt, then pull rapidly. Rapid retraction of starter cord (kickback) will pull hand and arm toward engine faster than you can let go. Broken bones, fractures, bruises or sprains could result.
9. Do not put hands or feet near rotating parts or under the cutting deck. Contact with the blade(s) can amputate hands and feet.
10. Watch for holes, ruts, bumps, rocks, or other hidden objects. Uneven terrain or hidden objects could cause a slip and/or trip accident. Tall grass can hide obstacles.
11. Your mower is designed to cut normal residential grass of a height no more than 7" (17.5 cm). Do not attempt to mow through unusually tall, dry grass (e.g., pasture) or piles of dry leaves.
12. Plan your mowing pattern to avoid discharge of material toward roads, sidewalks, helpers and the like. Avoid discharging material against a wall or obstruction which may cause discharged material to ricochet back toward the operator.
13. Shut the engine off and wait until the blade comes to a complete stop before removing the grass catcher or unclogging the chute. The cutting blade continues to rotate for up to three seconds after the blade control is released. Never place any part of the body in the blade area until you are certain the engine is off and the blade has stopped rotating.
14. A missing or damaged discharge door, chute or mulch plug can cause blade contact or thrown object injuries.
15. Do not operate the mower without the discharge door, chute, mulch plug or the entire grass catcher in its proper place.
16. Stop the mower blade when crossing gravel drives, walks, or roads and while not cutting grass.
17. Mow only in daylight or good artificial light.
18. Do not operate the mower while under the influence of alcohol or drugs.
19. The muffler and engine become very hot and can cause serious burn injuries. Do not touch. Allow the mower to cool for at least five minutes before storing or attempting any service.
20. Never run an engine indoors or in a poorly ventilated area. Engine exhaust contains carbon monoxide, an odorless and deadly gas.

Children

1. Tragic accidents can occur if the operator is not alert to the presence of children. Children are often attracted to the mower and the mowing activity. They do not understand the dangers. Never assume that children will remain where you last saw them.
2. Keep bystanders, children and pets inside while the mower is in operation under watchful care of a responsible adult other than the operator. Stop mower if anyone enters the area.
3. Be alert and turn mower off if a child or bystander enters the area.
4. Never allow children under 14 years of age to operate this mower. Children 14 and over should read and understand the instructions and safe operation practices in this manual and on the mower and should be trained and supervised by an adult.
5. This mower is a precision piece of power equipment, not a plaything. Therefore, exercise extreme caution at all times. This mower has been designed to perform one job: to mow grass. Do not use it for any other purpose.
6. Use extreme care when approaching blind corners, doorways, shrubs, trees or other objects that may block your vision of a child who may run into the path of the mower.
7. Keep children away from hot or running engines. They can suffer burns from a hot engine or muffler.
8. If your mower is equipped with an Electric Start Push Key, remove the key when the mower is unattended to prevent unauthorized operation. Make certain the key is inaccessible to small children.

SAFE OPERATION PRACTICES, cont'd

Slope Operation for Walk-Behind Mowers

1. Slopes are a major factor related to slip and fall accidents which can result in severe injury or death. All slopes require extra caution. If you feel uneasy on the slope, do not mow it.
2. For your safety, measure any slope before using the mower on the sloped area. Use a slope measuring device in addition to the slope gauge included as part of this manual to measure slopes before operating this mower on a sloped or hilly area. Smart phone applications can be also utilized to measure slopes. If the slope is greater than 15 degrees (25%) as shown on the slope gauge or a slope measuring device, do not operate this mower on that area or serious injury could result.
3. Do not mow on slopes greater than 15 degrees (25%).
4. Only mow across slopes, never mow up and down slopes.
5. The mower may speed up when turning downhill, always turn uphill. Maintain control of the mower at all times.
6. Do not mow on wet grass. Unstable footing could cause slipping.
7. Do not operate the mower under any conditions where traction or stability is in question. Always be sure of your footing. A slip and fall can cause serious personal injury. If you feel you are losing your balance or footing, release the blade control handle immediately and the blade will stop rotating within three (3) seconds.
8. Stay at least 3 feet (1 meter) from drop-offs, ditches, embankments or the edge of water. You could lose your balance or footing.

Fire & Fuel

1. To avoid personal injury or property damage use extreme care in handling gasoline. **Gasoline is extremely flammable and the vapors are explosive.** Serious personal injury can occur when gasoline is spilled on yourself or your clothes which can ignite. Wash your skin and change clothes immediately.
2. Extinguish all cigarettes, cigars, pipes and other sources of ignition.
3. Only use an approved portable fuel (gasoline) container. Use only containers certified by EPA, CARB, and/or OSHA.
4. Never remove gas cap or add fuel while the engine is hot or running. Allow engine to cool at least five minutes before refueling.
5. Never fuel the mower indoors.
6. Never store the mower or fuel container inside where there is an open flame, spark or pilot light as on a water heater, space heater, furnace, clothes dryer or other gas appliances.
7. If fuel is spilled, wipe it off the engine and mower. Clean up oil or fuel spillage and remove any fuel soaked debris. Move the mower to another area. Wait at least 5 minutes before starting the engine.
8. To reduce fire hazards, keep mower free of grass, leaves, or other debris build-up. Follow the instructions in the Service and Maintenance section to keep your mower free of debris.
9. Never over fill fuel tank. Fill tank to no more than 1" (25mm) below bottom of filler neck to allow space for fuel expansion.
10. Replace gas cap and tighten securely.
11. Allow a mower to cool at least five minutes before fueling or storing.
12. Never fill containers inside a vehicle or on a truck or trailer bed with a plastic liner. Always place containers on the ground away from your vehicle before filling.
13. When practical, remove gas-powered equipment from the truck or trailer and refuel it on the ground. If this is not possible, then refuel such equipment on a trailer with a portable container, rather than from a gasoline dispenser nozzle.
14. Keep the nozzle in contact with the rim of the fuel tank or container opening at all times until fueling is complete. Do not use a nozzle lock-open device.

Service

1. Keep the mower in good working order. Replace worn or damaged parts.
2. To avoid serious injury or death, do not modify engine in any way. Tampering with the governor setting can lead to a runaway engine and cause it to operate at unsafe speeds. Never tamper with factory setting of engine governor. Do not change the engine governor settings or over-speed the engine. The governor controls the maximum safe operating speed of the engine.
3. Mower blades are sharp. Wrap the blade or wear gloves, and use extra caution when servicing them.
4. Before cleaning, repairing, or inspecting, make certain the blade and all moving parts have stopped. Disconnect the spark plug wire and ground against the engine to prevent unintended starting.
5. Ensure the blade comes to a complete stop within (3) three seconds after operating the blade control. If the blade does not stop in less than three seconds, your mower must be serviced professionally by an authorized service dealer. Check for proper operation per the Service and Maintenance section.

SAFE OPERATION PRACTICES, cont'd

6. Regularly check the safety interlock system for proper function, as described later in this manual. If the safety interlock system does not function properly, have your mower serviced professionally by an authorized service dealer.
7. Never tamper with the blade control safety interlock or other safety devices. Check for proper operation per the Service and Maintenance section.
8. Check the mower blade and engine mounting bolt torque in accordance to the Service and Maintenance section in this manual. Also, visually inspect blade for damage (e.g., excessive wear, bent, cracked). Replace the blade with the original equipment manufacturer's (O.E.M.) blade only.
9. Use of service parts which do not meet the original equipment specifications may lead to improper performance and compromise safety.
10. Keep all nuts, bolts, and screws tight to be sure the equipment is in safe working condition. Check all hardware for tightness per the Service and Maintenance section.
11. After striking a foreign object, stop the engine, disconnect the spark plug wire(s) and ground against the engine. Thoroughly inspect the mower for any damage. Repair the damage before starting and operating.
12. Never attempt to make wheel cutting height adjustments or repairs to the mower while the engine is running.
13. Grass catcher components and the discharge cover are subject to wear and damage which could expose moving parts or allow objects to be thrown. For safety protection, frequently check components and replace immediately with original equipment manufacturer's (O.E.M.) parts only. "Use of parts which do not meet the original equipment specifications may lead to improper performance and compromise safety."
14. Maintain or replace safety and instruction labels, as necessary.
15. Observe proper disposal laws and regulations for gas, oil, etc. to protect the environment.

Notice Regarding Emissions

Engines which are certified to comply with California and federal EPA emission regulations for SORE (Small Off Road Equipment) are certified to operate on regular unleaded gasoline, and may include the following emission control systems: Engine Modification (EM) and Three Way Catalyst (TWC) if so equipped.

When required, models are equipped with low permeation fuel lines and fuel tanks for evaporative emission control. California models may also include a carbon canister. Please contact Customer Support for information regarding the evaporative emission control configuration for your model.

Spark Arrestor



WARNING: *This mower is equipped with an internal combustion engine and should not be used on or near any unimproved forest-covered, brush-covered or grass-covered land unless the engine's exhaust system is equipped with a spark arrestor meeting applicable local or state laws (if any).*

If a spark arrestor is used, it should be maintained in effective working order by the operator. In the State of California the above is required by law (Section 4442 of the California Public Resources Code). Other states may have similar laws. Federal laws apply on federal lands.

A spark arrestor for the muffler is available through your nearest engine authorized service dealer or contact the service department, P.O. Box 361131 Cleveland, Ohio 44136-0019.

Slope Gauge (Back Cover)



WARNING: *Slopes are a major factor related to slip and fall accidents which can result in severe injury or death. All slopes require extra caution. If you feel uneasy on the slope, do not mow it. Do not mow on slopes greater than 15 degrees (25%). Only mow across slopes, never mow up and down slopes.*











USE THE SLOPE GAUGE ON THE BACK COVER AS SHOWN TO DETERMINE IF A SLOPE IS TOO STEEP FOR SAFE OPERATION!

To check the slope, proceed as follows:

1. Open manual to page and fold along the dashed line.
2. Locate a vertical object on or behind the slope (e.g. a pole, building, fence, tree, etc.)
3. Align either side of the slope gauge with the object.
4. Adjust gauge up or down until the left corner touches the slope.
5. If there is a gap below the gauge, the slope is too steep for safe operation.

SAFE OPERATION PRACTICES, cont'd

This page depicts and describes safety symbols that may appear on this mower. Read, understand, and follow all instructions on the mower before attempting to assemble and operate.

Symbol	Description
 <p>OPESymbol.com</p>	<p>WARNING — READ THE OPERATOR'S MANUAL(S) - Read, understand and follow all the safety rules and instructions in the manual(s) and on the mower before attempting to operate this mower. Failure to comply with this information may result in personal injury or death. Keep this manual in a safe location for future and regular reference.</p>
	<p>DANGER — AVOID AMPUTATION INJURY - Do not put hands or feet near or under the cutting deck. Contact with the blade can amputate hands and feet.</p>
	<p>DANGER — AVOID THROWN OBJECT INJURY - Remove all stones, sticks, wire, bones, toys, and other foreign objects which could be picked up and thrown by the blade(s). Stay in the operator zone behind the mower handles. Keep helpers at least 75 feet (23 meters) from mower during operation. Stop mower if anyone enters the area.</p>
	<p>DANGER — AVOID CHILD BLADE CONTACT/THROWN OBJECT INJURY - To help avoid blade contact or a thrown object injury, do not mow when children or others are around. Keep bystanders, children and pets inside while the mower is in operation. Stop mower if anyone enters the area.</p>
	<p>DANGER — AVOID THROWN OBJECT INJURY - Do not operate the mower without the trail shield, discharge cover or entire grass catcher in its proper place. Stay in the operator zone behind the mower handles.</p>
	<p>DANGER — ROTATING BLADES - To reduce the risk of injury, keep hands and feet away. Do not operate unless discharge cover or entire grass catcher is in its proper place. If damaged, replace immediately.</p>
	<p>DANGER — AVOID SLIP AND FALL ON SLOPES - Slopes are a major factor related to slip and fall accidents which can result in severe injury or death. All slopes require extra caution. If you feel uneasy on the slope, do not mow it. Do not mow on slopes greater than 15 degrees (25%). Only mow across slopes, never mow up and down slopes.</p>
	<p>DANGER — AVOID EYE INJURY - Always wear safety glasses or safety goggles during operation and while performing an adjustment or repair to protect your eyes. Thrown objects which ricochet can cause serious injury to the eyes.</p>
	<p>DANGER — AVOID TRIPPING INJURY - Never pull the mower back toward you while you are walking. If you must back the mower away from a wall or obstruction first look down and behind to avoid tripping.</p>
	<p>WARNING — GASOLINE IS FLAMMABLE - Allow the engine to cool at least five minutes before refueling.</p>
	<p>WARNING — AVOID BURN INJURY - The muffler and engine become very hot and can cause serious burn injuries. Do not touch. Allow the mower to cool for at least five minutes before storing or attempting any service.</p>

! WARNING: YOUR RESPONSIBILITY—Restrict the use of this power machine to persons who read, understand and follow the warnings and instructions in this manual and on the machine - SAVE THESE INSTRUCTIONS!

ASSEMBLY

IMPORTANT: This mower is shipped without gasoline or oil in the engine. Be certain to service engine with gasoline and oil as instructed in the Operation section of the Engine Manual before starting or operating your mower.

NOTE: Reference to right and left hand side of the Lawn Mower is observed from the operating position.

Unpacking

Opening Carton

1. Cut each corner of the carton vertically from top to bottom.
2. Remove all loose parts:
 - Grass Catcher (if equipped)
 - Engine Oil
3. Remove loose packing material.

Removing Mower From Carton

1. Lift mower from the rear to detach it from underlying carton material and roll mower out of carton.
2. Check carton thoroughly for any other loose parts.
3. Remove all packing material from the upper and lower handle including any packaging securing the blade control to the upper handle and any packaging between upper and lower handles.

Mower Assembly

Perform the following procedures to assemble and set up the mower:

- **Handle Assembly**
- **Recoil Starter Rope Handle Assembly**
- **Attaching the Grass Catcher (if equipped)**
- **Attaching Side Discharge Chute or Side Discharge Blower (if equipped)**

NOTE: Refer to the procedures in Adjustments to adjust the cutting height, handle angle (if equipped) and drive control (if equipped) as necessary.

Handle Assembly

1. Remove knobs or wing nuts (a) and carriage bolts (b) from the handle (Figure 1).

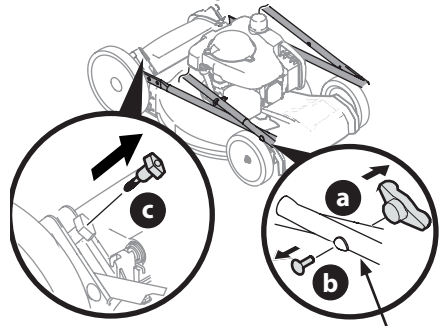

Do not loosen or remove hex head screws.

Figure 1

2. Remove the T-bolts (c) from the handle brackets (Figure 1).
3. While stabilizing mower so it doesn't move, gently lift and pivot the upper handle into the operating position (Figure 2). Make certain the lower handle is seated securely into the handle brackets. Do not crimp control cables while lifting the handle up.

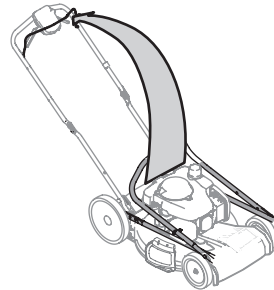

Figure 2

ASSEMBLY, cont'd

4. Reattach knobs or wing nuts (a) and carriage bolts (b) removed in STEP 2 into the handle (Figure 3).

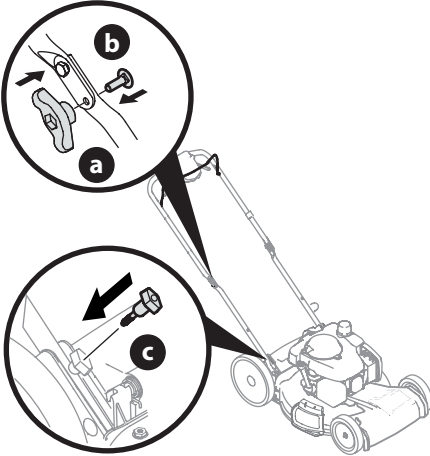

Figure 3

Recoil Starter Rope Handle Assembly

NOTE: The rope guide is attached to the right side of the upper handle. Loosen the knob securing the rope guide (Figure 4).

NOTE: Select units include a slip knot in the recoil starter rope to reduce slack during shipping. Ensure slip knot is released before performing this procedure.

1. Hold blade control against upper handle.
2. Slowly pull recoil starter rope handle from engine and slip starter rope into the rope guide.
3. Tighten rope guide knob.

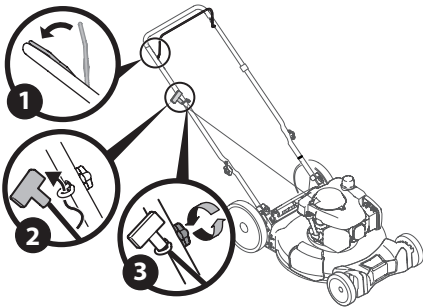

Figure 4

4. If necessary, tighten any loose cable ties (a) securing cables to the handle (Figure 5).

IMPORTANT: To reduce wear and allow for proper operation, make sure to leave some slack in the upper portion of the cables.

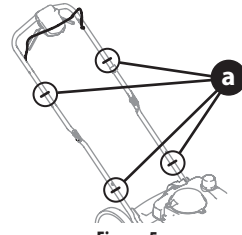

Figure 5

Attaching the Grass Catcher (If Equipped)

1. Perform the following to assemble the grass catcher (Figure 6).

NOTE: Before assembling the grass catcher, ensure the grass bag is turned right side out, with the warning label showing on the outside.

- a. Place bag over frame so that its black plastic side is at the bottom.
- b. Slip plastic channels (a) of grass bag over the frame (b).

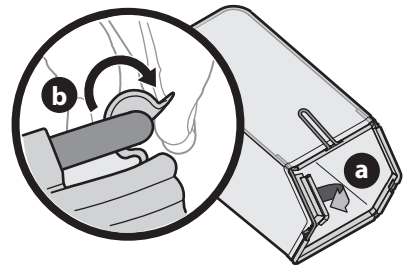

Figure 6

2. Follow steps below to attach grass catcher (Figure 7):
 - a. Lift rear discharge door (a).
 - b. Remove the rear mulch plug (b) (if equipped).
 - c. Place grass catcher into the slots in the handle brackets (c). Lower the discharge door so that it rests on the grass catcher.

NOTE: To remove grass catcher, lift rear discharge door on the mower. Lift grass catcher up and off the slots in

ASSEMBLY, cont'd

the handle brackets. Reinstall the rear mulch plug (if equipped). Release rear discharge door to allow it to close rear opening of mower.

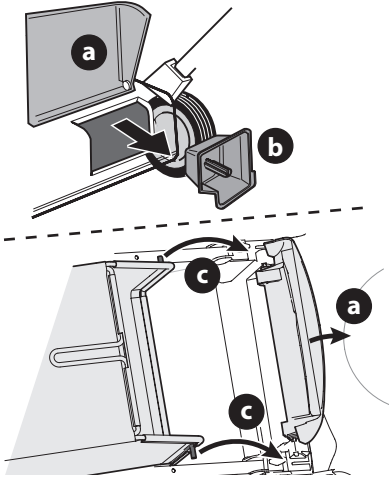

Figure 7

Attaching Side Discharge Chute (If Equipped)

The mower is shipped as a mulcher. To convert to side discharge, ensure the grass catcher is removed, the rear mulch plug is installed (if equipped) and the rear discharge door is closed.

1. Lift the mulch plug (Figure 8).
2. Slide the two hooks of the side discharge chute (a) under the mulch plug hinge pin. Lower the mulch plug.

IMPORTANT: Do not remove side mulch plug at any time.

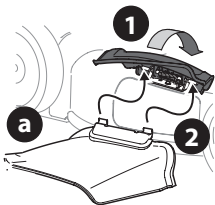

Figure 8

Cutting Height Adjustments

This mower is equipped with one of three types of cutting height adjustment. Refer to Single Lever, Dual Lever or Rear Wheel/Caster Wheels in this section.

Rear Wheel Drive Mowers - The dual lever cutting height adjustment levers are located above the front and rear left wheels.

NOTE: On select mowers - The front and rear height adjustment levers move in the opposite direction to adjust height.

1. Carefully pull the height adjustment lever outward towards wheel (mower will tend to fall when lever is moved outward). Figure 9
2. Move lever to desired position for a change in cutting height.
3. Release lever towards deck.

IMPORTANT: All wheels must be placed in the same position. For rough or uneven lawns, move each height adjustment lever to a higher position. This will prevent you from cutting the grass too close to the ground.

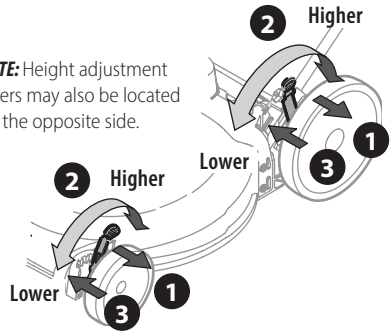

Figure 9

ASSEMBLY, cont'd

Handle Pitch (If Equipped)

For convenience of operation, you may adjust the pitch of the handle. Perform one of the following.

1. Remove wing nuts and carriage bolts from handle (Figure 10).
2. Position the handle in one of the three positions that is most comfortable. See Figure 10 inset.
3. Secure into position with wing nuts and carriage bolts removed in STEP 1.

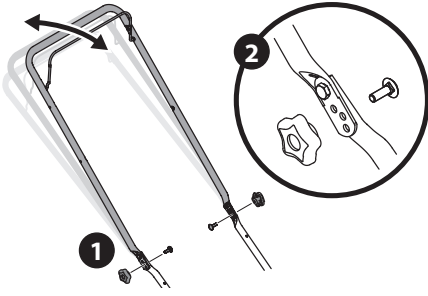

Figure 10

Drive Control Adjustment

Single Lever and Dual Lever Drive Controls (If Equipped)

If equipped, there is an adjustment wheel located in the drive control handle housing that is used to tighten or loosen the drive belt. You will need to adjust the drive control if the mower does not propel itself with the drive control engaged or if the mower's wheels hesitate with the drive control engaged. If either of these conditions occur, rotate adjustment wheel clockwise to tighten cable or counterclockwise to loosen the cable. See Figure 11 for location on Single Lever Drive Control and Figure 12 for Dual Lever Drive Control.

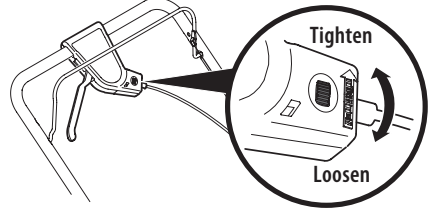

Figure 11

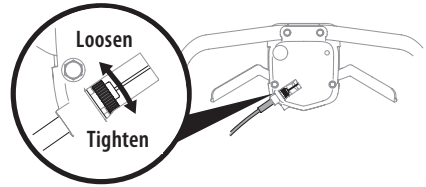

Figure 12

CONTROLS & OPERATION

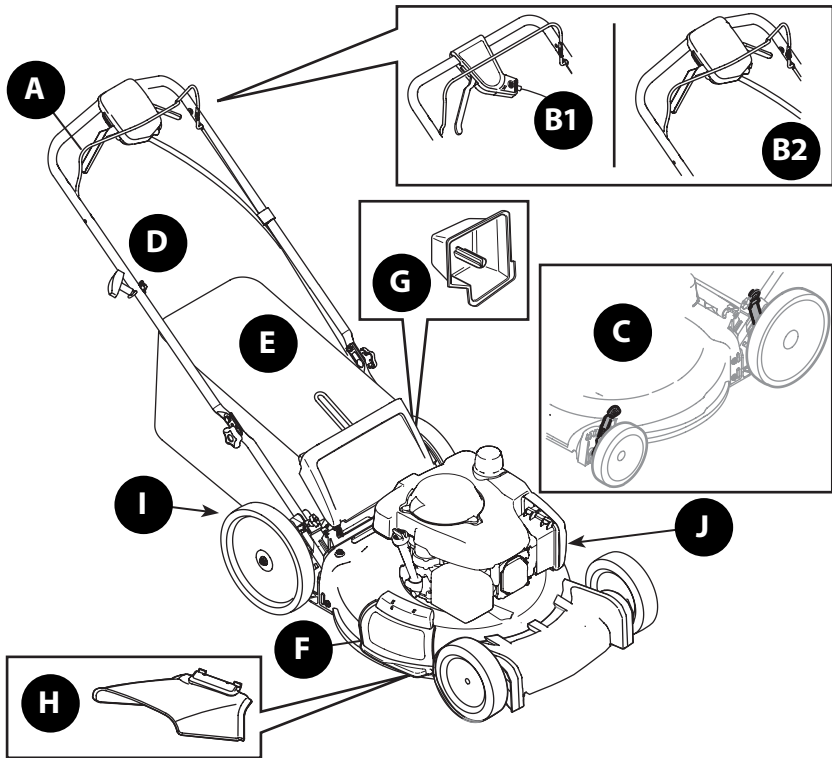

Figure 13

Features

A. BLADE CONTROL

The blade control is attached to the upper handle of the mower. Depress and squeeze it against the upper handle to operate the mower. Release the blade control to stop blade and engine.

! **WARNING:** *This blade control is a safety device. Never attempt to bypass its operation.*

B. DRIVE CONTROL

There are four drive control configurations.

- 1. Single Lever Drive Control (If Equipped)** - The single lever drive control is located on top of the upper handle and is used to engage the drive. Squeeze it against the upper handle to engage the drive; release it to slow down or stop mower.
- 2. Dual Lever Drive Controls (If Equipped)** - The dual lever drive controls are located on top of the upper handle and are used to engage the drive. Squeeze the right, left, or both right and left controls against the upper handle to engage the drive; release it/them to slow down or stop mower.

C. CUTTING HEIGHT ADJUSTMENT LEVER

The dual lever cutting height adjustment levers are located above the front and rear wheels. To adjust the cutting height, refer to Cutting Height Adjustment on page 11.

D. RECOIL STARTER

The recoil starter is attached to the right upper handle. Stand behind the mower and pull the recoil starter rope to start the mower.

E. GRASS CATCHER (IF EQUIPPED)

The grass catcher, located at the rear of the mower, is used to collect the grass clippings for disposal. Once the bag is full, remove it up through the handles and empty it before any further mowing.

F. MULCH PLUG (IF EQUIPPED)

The mulch plug is located on the right side of the mower and is used for mulching purposes (recirculating the clippings back to the lawn).

CONTROLS & OPERATION, cont'd

G. REAR MULCH PLUG (IF EQUIPPED)

On select mowers, the mulch plug is a separate component. If equipped, this mulch plug must be installed into the rear bagging discharge area when using the mower as a mulcher (recirculating the clippings back to the lawn) or side discharge.

H. SIDE DISCHARGE CHUTE (IF EQUIPPED)

The side discharge chute is used to discharge grass clippings to the side of the mower instead of collecting the clippings in the grass catcher or using the mower as a mulcher.



WARNING: *Keep hands and feet away from the chute area on cutting deck. Refer to warning label on the unit.*

I. TRAIL SHIELD

The trail shield is attached to the rear of the mower and is there to protect the operator from flying debris. Do not use the mower unless the shield is fully functional and in place.

J. DECK WASH (IF EQUIPPED)

Your mower's deck may be equipped with a fast attach deck wash nozzle on its surface as part of its deck wash system. Use the deck wash to rinse grass clippings from the deck's underside.

Gasoline And Oil Fill-up

IMPORTANT: Refer to the separate Engine Operator's Manual for additional engine information.

This mower is shipped without gasoline (fuel) or oil in the engine. Be certain to service engine with gasoline and oil as instructed before starting or operating your lawn mower.

1. Add provided oil before starting mower for the first time as instructed in the separate Engine Operator's Manual.
2. Service the engine with gasoline as instructed in the separate Engine Operator's Manual.



WARNING: *Use extreme care when handling gasoline. Gasoline is extremely flammable and the vapors are explosive. Never fuel the machine indoors or while the engine is hot or running. Extinguish cigarettes, cigars, pipes and other sources of ignition.*

To Start Engine



WARNING: *Be sure no one other than the operator is standing near the lawn mower while starting engine or operating mower. Never run engine indoors or in enclosed, poorly ventilated areas. Engine exhaust contains carbon monoxide, an odorless and deadly gas. Keep hands, feet, hair and loose clothing away from any moving parts on engine and lawn mower.*

Refer to the Engine Operator's Manual for instructions on starting and stopping the engine.

To Stop Engine

Release blade control to stop the engine and blade.

NOTE: If equipped with an electric starter push key, remove the key when the mower is unattended to prevent unauthorized operation.



WARNING: *Wait for the blade to stop completely before performing any work on the mower or to remove the grass catcher.*

Check blade stopping time is within 3 seconds. If blade does not stop within 3 seconds contact your Service Center.

Using Your Lawn Mower



WARNING: *The operation of any lawn mower can result in foreign objects being thrown into the eyes, which can damage your eyes severely. Always wear safety glasses while operating the mower, or while performing any adjustments or repairs.*

Be sure lawn is clear of stones, sticks, wire, or other objects which could damage lawn mower or engine. Such objects could be thrown by the blade in any direction and cause serious personal injury to the operator and helpers.

CONTROLS & OPERATION, cont'd

Single Lever Drive Control (If Equipped)

1. Once the engine is running, squeeze the single lever drive control against the upper handle to propel mower.
2. Release the single lever drive control to slow down or stop mower from propelling.

Dual Lever Drive Controls (If Equipped)

1. Once the engine is running and while continuing to hold the blade control down, squeeze either (or both) drive controls against the upper handle to propel mower (Figure 14).

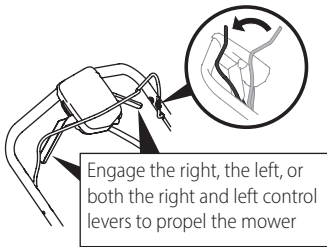

Figure 14

2. Release the dual lever drive controls to slow down or stop mower.
3. Speed Control (if equipped) - To change speed, move speed control to the desired speed.

NOTE: When selecting a drive speed, use the first speed until you are comfortable and familiar with the operation of the mower.

IMPORTANT: If you are shifting speeds while the mower is stationary it may be difficult to shift into first speed under certain conditions. This is easily remedied by briefly engaging the drive lever.

NOTE: Your mower is equipped with an advanced internal drive system for ease of use and smooth shifting. When turning or pulling the unit rearward, you may notice higher than normal resistance in the rear wheels under certain conditions. This is perfectly normal and can be remedied by allowing the unit to roll forward slightly without the drive lever(s) engaged before pulling backwards.

Using Side Discharge Chute (If Equipped)

To use the mower without mulching or collecting grass, remove the grass catcher and ensure the rear mulch plug (if equipped) is installed. Allow the rear discharge door to close the rear opening of mower. Refer to Attaching The Side Discharge Chute in on page 11.

Using Mower as a Mulcher (If Equipped)

For mulching grass, remove the grass catcher or side discharge chute from the mower. When you remove the grass catcher from the mower, ensure the rear mulch plug (if equipped) is installed and allow the rear discharge door to close the rear opening of mower. When you remove the side discharge chute, the mulching plug will close. For effective mulching, do not cut wet grass. If the grass has been allowed to grow in excess of four inches, mulching is not recommended. Use the grass catcher to collect clippings instead.

Using Mower with Grass Catcher (If Equipped)

You can use the grass catcher to collect clippings while you are operating the mower.

1. Attach grass catcher, refer to Attaching the Grass Catcher on page 10. Grass clippings will automatically collect in bag. Operate mower until grass bag is full.
2. Stop engine by releasing the blade control. Make sure that the engine has come to a complete stop.
3. Lift rear discharge door and pull grass bag up and away from the mower to remove the bag. Dispose of the grass clippings and reinstall the bag when complete.

WARNING: If you strike a foreign object, stop the engine. Disconnect the spark plug wire, thoroughly inspect mower for any damage, and repair damage before restarting and operating. Extensive vibration of mower during operation is an indication of damage. The mower should be promptly inspected and repaired.

WARNING: Before performing any type of maintenance/service, disengage all controls and stop the engine. Wait until all moving parts have come to a complete stop. Allow the engine to cool. Disconnect spark plug wire and ground it against the engine to prevent unintended starting.

PRODUCT CARE

General Recommendations

- Always observe safety rules on the mower and in the manual(s) when performing any maintenance.
- The warranty on this mower does not cover items that have been subjected to operator abuse or negligence. To receive full value from warranty, operator must maintain the mower as instructed here.
- Changing of engine-governed speed will void engine warranty.
- Check that all hardware is in place & secure and tight before each use and before off season storage.

Lubrication

Blade Control

Lubricate pivot points on the blade control at least once a season and before storage with light oil. This control must operate freely in both directions (Figure 15).

Wheels

Lubricate all wheel hubs/axles at least once a season and before storage with light oil (Figure 15).

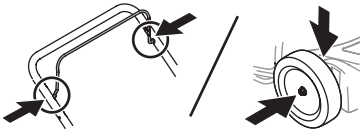

Figure 15

Engine Maintenance

Annually check the engine mounting bolts torque: Min. 29.2 ft-lbs (39.6 N-m), Max. 41.7 ft-lbs (56.3 N-m).

Refer to the Engine Operator's Manual packed with your mower for a detailed description of all engine-related service specifications and storage.

If engine fails to start, runs erratic, overheats, skips (hesitates) or idles poorly refer to the Engine Operator's Manual.

IMPORTANT: Check engine oil level before each use. Refer to Engine Operator's Manual.

Clean Engine

- Before every use, clean grass, chaff or accumulated debris from engine. Keep linkage, spring, and controls clean. Keep area around and behind muffler free of any combustible debris.
- Keeping engine clean allows air movement around engine.
- Engine parts should be kept clean to reduce the risk of overheating and ignition of accumulated debris.

CAUTION: Do not use water to clean engine parts. Water could contaminate fuel system. Use a brush or dry cloth.

Mower Maintenance

Deck Cleaning

At least once a season and before storage, clean the underside of the mower deck to prevent build-up of grass clippings or other debris.

1. Allow the engine to run until it is out of fuel. Do not attempt to pour fuel from the engine. Disconnect spark plug wire. Refer to Engine Operator's Manual.
2. Turn mower on its side keeping the muffler side down and making sure that the air filter and the carburetor are facing up. Hold mower firmly.
3. Scrape and clean the underside of the deck with a suitable tool. Do not spray with water.

IMPORTANT: Do not use a pressure washer or garden hose to clean your mower. These may cause damage to bearings, or the engine. The use of water will result in shortened life and reduce serviceability.

4. Put the mower back on its wheels on the ground.

Blade Care

WARNING: Wait for the blade to stop completely before performing any work on the mower or to remove the grass catcher.

Check blade stopping time is within 3 seconds. If blade does not stop within 3 seconds contact your Service Center.

WARNING: When removing the cutting blade for sharpening or replacement, protect your hands with a pair of heavy gloves or use a heavy rag to hold the blade.

Annually check the mower blade mounting bolt torque: Min. 37.5 ft-lbs (50.8 N-m), Max. 50.0 ft-lbs (67.8 N-m).

Periodically inspect the blade and blade adapter for bends or cracks, especially if you strike a foreign object or experience excessive vibration. Replace when necessary. Follow the steps below for blade service:

1. Allow the engine to run until it is out of fuel. Do not attempt to pour fuel from the engine.
2. Disconnect spark plug wire. Refer to Engine Operator's Manual.

PRODUCT CARE, cont'd

- Turn mower on its side keeping the muffler side down and making sure that the air filter and the carburetor are facing up.
- Remove bolt (a) and blade bell support (b) which hold the blade and the blade adapter to the engine crankshaft (Figure 16).
- Remove blade (c) and blade adapter (d) from the crankshaft (Figure 16).
- Remove blade from the blade adapter for testing balance.
 - Balance the blade on a round shaft screwdriver to check.
 - Remove metal from the heavy side until it balances evenly.

NOTE: When sharpening the blade, follow the original angle of grind. Grind each cutting edge equally to keep the blade balanced.

! **WARNING: An unbalanced blade will cause excessive vibration when rotating at high speeds. It may cause damage to engine and blade could break causing personal injury.**

- Lubricate the engine crankshaft and the inner surface of the blade adapter with light oil (Figure 16 inset).
 - Slide the blade adapter (d) onto the engine crankshaft.
 - Place the blade on the adapter such that the side of the blade marked "Grass Side" (or with part number) faces the ground when the mower is in the operating position.
 - Make sure that the blade is aligned and seated on the blade adapter flanges.

- Place blade bell support (b) on the blade (c). Align notches on the blade bell support with small holes in blade.
- Replace hex bolt (a) and tighten hex bolt to torque: Min. 37.5 ft-lbs (50.8 N-m), Max. 50.0 ft-lbs (67.8 N-m).

NOTE: To ensure safe operation of your mower, periodically check the blade bolt for correct torque.

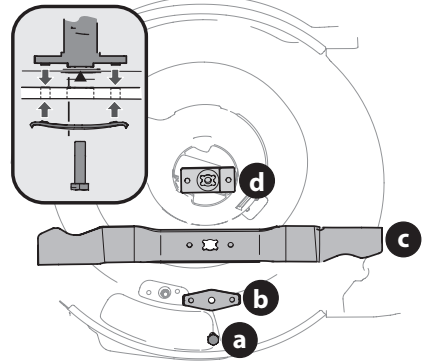

Figure 16

Belt Care

A damaged or worn belt may prevent the mower from self-propelling. Periodically inspect the belt and pulley system for damage or wear. If necessary contact an authorized Service Center to have belt replaced.

NOTE: Several components must be removed in order to change the mower's drive belt. See an authorized Service Center to have belt replaced.

PRODUCT CARE, cont'd

Customer Support



For machines needing service or parts replacement please contact your local DEWALT® Service Center or the Customer Support Department before attempting to return the machine.

If you have difficulty assembling this product, have questions regarding the controls, operation, or maintenance of this machine, want to order replacement parts/attachments/accessories, or want to view an online How-To video; you can seek help from the experts. Have your full model number and serial number ready. Choose from the options below:

◇ **Web:** www.DeWALT.com

◇ **Phone:** (855) 971-1123

Replacement Parts

Part Number	Description
634-07619	Wheel (Front - 8" x 2")
634-07731	Wheel (Rear - 8" x 2")
634-07634	Wheel (Rear - 11" x 2")
942-0741A	Mulching Blade (Bow Tie Mount )
742P05643	Mulch Blade (S Mount  , Serial numbers starting with the number 2 only.)
731-07486	Discharge Chute
664-05794	Grass Bag (Bag Only)
954-04282	Belt (RWD)

Accessories Parts

Part Number	Description
490-850-0005	Blade Removal Tool
490-850-0018	Spark Plug Wrench
490-850-0008	Oil Siphon
490-850-0016	Side Discharge Blower
490-290-0012	Mower Cover

DEWALT® -- LIMITED WARRANTY

Three Year Limited Warranty

For warranty terms, go to www.dewalt.com/support/warranty.

To request a written copy of the warranty terms, contact: Customer Service at DEWALT Industrial Tool Co., 701 East Joppa Road, Towson, MD 21286 or call 1 800 4 DEWALT (1 800 433 9258).

Latin America: This warranty does not apply to products sold in Latin America. For products sold in Latin America, see country specific warranty information contained in the packaging, call the local company or see website for warranty information.

free warning label replacement: If your warning labels become illegible or are missing, call 1 800 4 DEWALT (1 800 433 9258) for a free replacement.

SLOPE GAUGE

