

DCN890 Disassembling Procedure and General Information



BATTERY INDICATOR

Battery Indicator



	<p>Low Battery Replace battery with charged back</p>
	<p>Hot Pack Let the battery cool or replace it with a cool pack</p>
	<p>Jam/Stall Condition Rotate the stall release lever to release Refer to stall release</p>
	<p>Hot Tool Let the tool cool down before continuing use</p>
	<p>Error Reset the tool by removing and reinstalling battery pack, or cycling trigger lock off. If error code persist, take the tool to an authorized DEWALT service center</p>

FORCED ENTRY USERS

1. DRYWALL TRACK

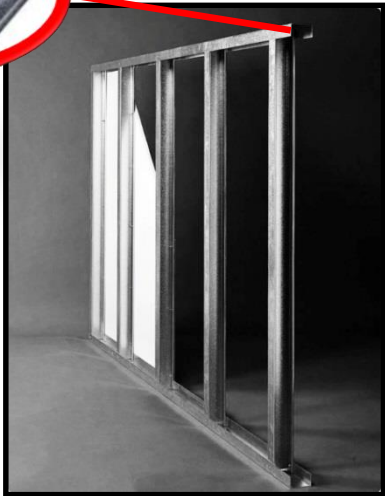

Range : 25-40mm
15mm Penetration for hard material
32mm Penetration for soft material



Range : 15-40mm
7mm Penetration

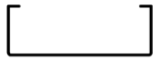

40-150mm
25-16Ga (0.45 – 1.29mm)



Tool Free Stall Release

XR Li-ion System 5 Amp

Angled Magazine

Easy Access Probe

DeWALT Proprietary pins 13-57mm

REMOVAL FOOT

HOW WE WIN



Quick Release Nose Piece



Brushless Motor



Stall Indicator (Underside of Magazine)



Battery Indicator



Single or Rapid Mode



Speed Control



1. PINS

- **3 TYPES OF PIN**
 - **Std – Collation colour – Yellow**
 - **HD- High Shear – Collation colour – Black**
 - **XH Extra Hard – Collation Colour Red**
- **COLLATION**
 - **Std – 15 Pins per strip**
 - **1 Exception 13mm XH due to pin length Collation Qty 10**
- **CARTON QTY**
 - **510, 1000, 1005 Dependant on Pin length and collation Qty**
 - **MASTER CARTON QTY**
 - **6 x pin pack**



ACCESSORIES - PINS

STD PINS							
CAT No	Length (mm)	Dia (mm)	Collation Qty	Box Qty	M Carton Qty *	BAR CODE	APPLICATIONS
DCN8901015	15	2.6	15	1005	6030	5054905022334	CONCRETE
DCN8901020	20	2.6	15	1005	6030	5054905022341	CONCRETE
DCN8901025	25	2.6	15	1005	6030	5054905022358	CONCRETE
DCN8901030	30	2.6	15	1005	6030	5054905022365	CONCRETE
DCN8901035	35	2.6	15	1005	6030	5054905022372	CONCRETE
DCN8901040	40	2.6	15	1005	6030	5054905022389	CONCRETE
DCN8901045	45	2.6	15	510	3060	5054905022396	CONCRETE
DCN8901050	50	2.6	15	510	3060	5054905022402	CONCRETE
DCN8901055	55	2.6	15	510	3060	5054905022419	CONCRETE
DCN8901057	57	2.6	15	510	3060	5054905022426	CONCRETE
HD pins							
	Length (mm)	Dia (mm)	Collation Qty	Box Qty	M Carton Qty	BAR CODE	
DCN8902015	15	3.7	15	1005	5025	5054905022433	MET SEC APPLICATIONS
DCN8902020	20	3.7	15	1005	5025	5054905022440	MET SEC APPLICATIONS
DCN8902025	25	3.7	15	1005	5025	5054905022457	
XH pins							
	Length (mm)	Dia (mm)	Collation Qty	Box Qty	M Carton Qty	BAR CODE	
DCN8903013	13	3.0	10	1000	6000	5054905022464	Steel to Steel
DCN8903017	17	3.0	15	1005	6300	5054905022471	
DCN8903022	22	3.0	15	1005	6300	5054905022488	Track or metal clips on hard concrete
DCN8903027	27	3.0	15	1005	6300	5054905022495	
DCN8903032	32	3.0	15	1005	6300	5054905022501	
DCN8903038	38	3.0	15	1005	6300	5054905022518	
DCN8903043	43	3.0	15	510	3060	5054905022525	Single 19mm deflector
DCN8903048	48	3.0	15	510	3060	5054905022532	Double 12.5mm deflector
DCN8903053	53	3.0	15	510	3060	5054905022549	Double 15mm defelctor
DCN8903057	57	3.0	15	510	3060	5054905022556	Double 19mm deflector (temp fixing before mechanical fixing is used)

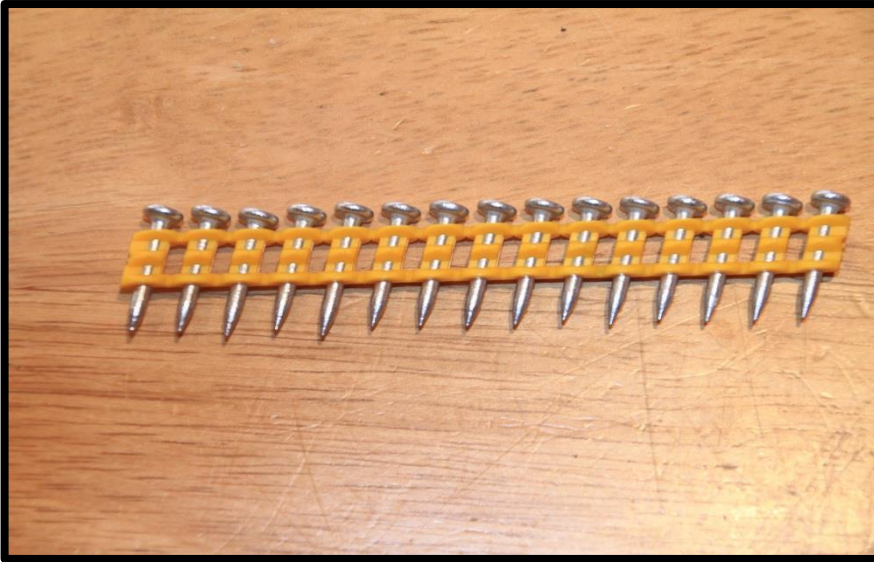

- **PINS**
 - **13 – 57mm**
 - **Diameter 2.6-3.7mm**
 - **Angle 15 degrees**
 - **Machine Capacity 33 Pins**

DDF6755012	TILW-PULSA-LW	
DDF6755315	ST-COND-24-DBL	
DDF6775320	*ST-COND-28-DBL	
DDF6710000	COND-16-DBL	
DDF6710050	COND-20-DBL	
DDF6710100	COND-24-DBL	
DDF6750000	25mm Lathing Washer	
DDF6750050	36mm Insulated Washer	
DDF6750100	13mm Lathing Washer	
DDF6750150	DDF6750150	

DDF6770000	Eye Clip	
DDF6720000	25mm cable tie	
DDF6755402	QKCLPII14-18	
DDF6755404	QKCLPII20-25	
DDF6755406	QKCLPII26-32	
DDF6753200	TICOND20MM metal conduit Clip	
DDF6753205	TICOND22MM metal conduit Clip	
DDF6755000	CABLE-BOW-SINGLE	
DDF6755003	CABLE-BOW-DOUBLE	

Magnetic Stick E Tip DCN8902-XJ APPLICATIONS

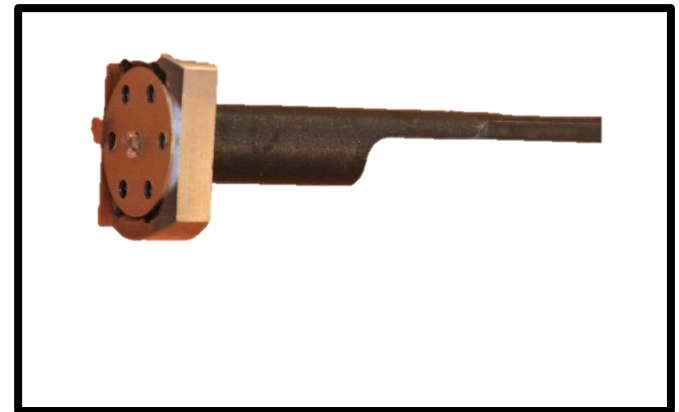
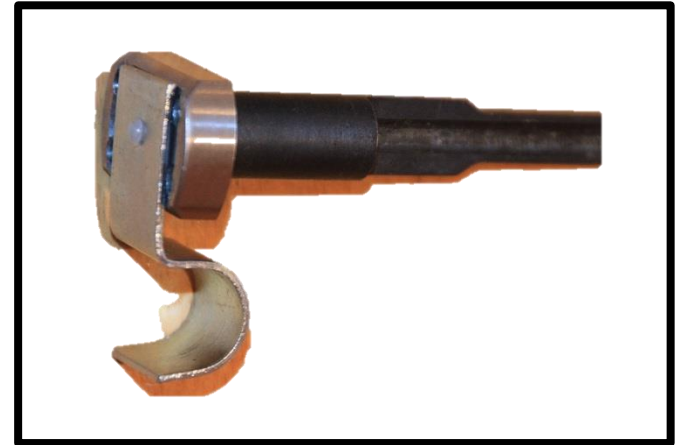

**Non Magnetic Stick E Tip
DCN8903-XJ APPLICATIONS**



CONTACT TRIPS REMOVAL & REPLACEMENT

Magnetic Contact Trip
DCN8902



DEWALT DCN8903-XJ NON-MAGNETIC CONTACT



**REPLACEMENT
DRIVER**



DCN8901-XJ

TRACK IT POLE



**DCN8905-XJ SIMILAR TO
POWERS 55048**

Core Kitted SKU



DCN890P2

- 1 x DCN890P2
- 2 x 5.0Ah Batteries
- 1 x M/V Charger
- 1 x Kitbox
- 2 x Contact Trips
DCN8903 DCN8904

Core Naked SKU

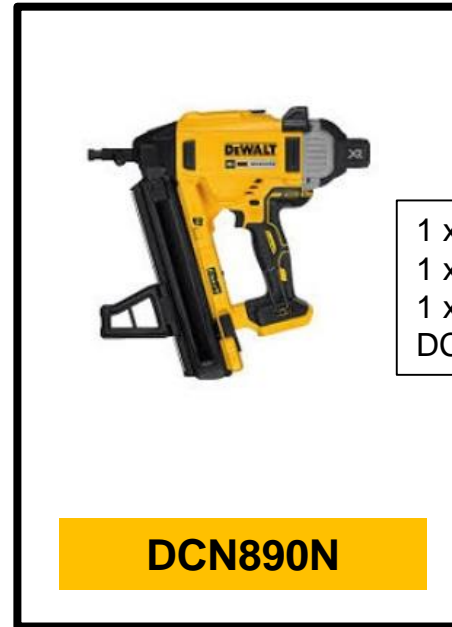

DCN890N

- 1 x DCN890
- 1 x cardboard carton
- 1 x Contact Trip Only
DCN8904

Single Flywheel System

- Quantify Key Design Parameters
 - Inertia, Flywheel Speed, Driver Mass, Pinch Force, V Angle
- Performance Verification - Prototype
 - Penetration in 4000 psi concrete / A36 steel
 - Pin retention force in steel and concrete
 - Recoil acceleration benchmarking
 - End-user validation
- Size and Weight Limits – User Research
 - 4.2 Kgs Determined Acceptable

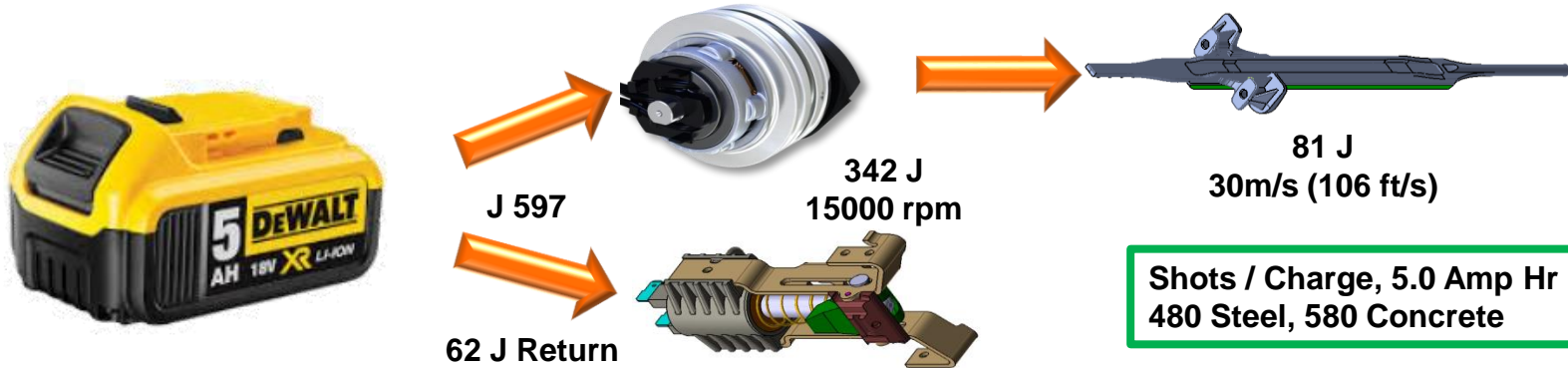

ENGINEERING – DRIVER SYSTEM (REASSEMBLED)

Material

Induction Hardened AISI 6150

Profile / Driver Design -
Hot forging with Return Rack

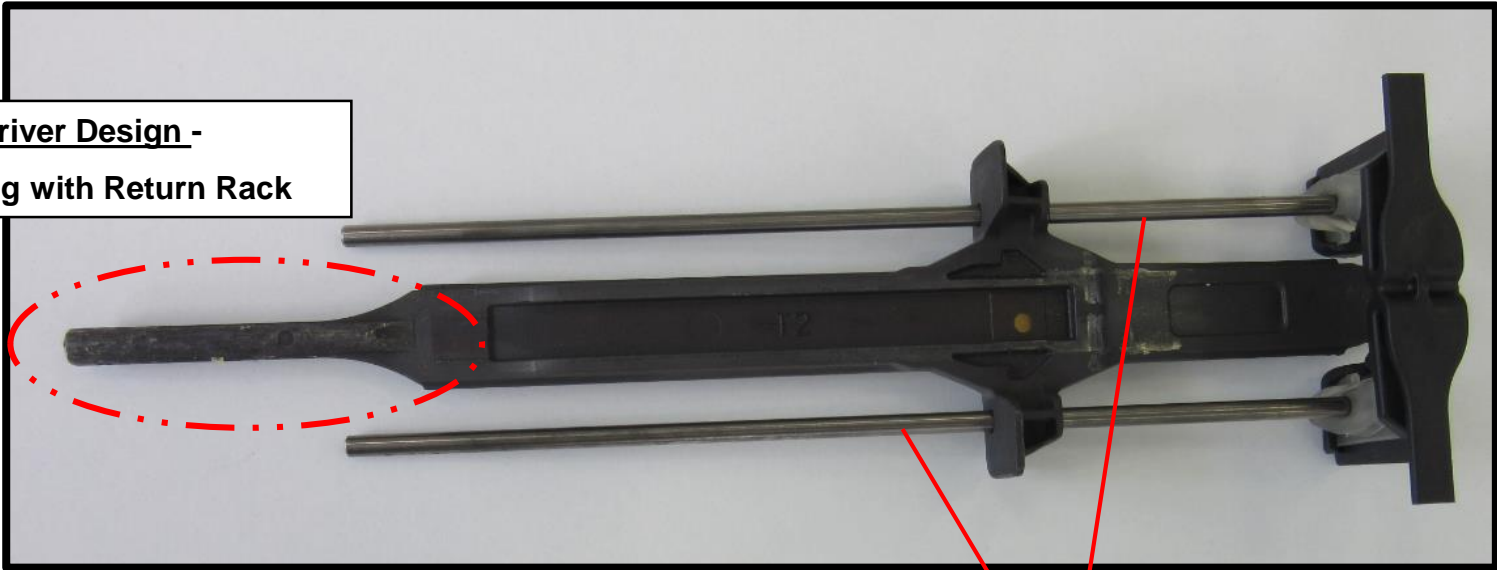

GUIDE RODS

ENGINEERING – DRIVER SYSTEM

FRICION SURFACE



VIEW FROM TOP

CONTACT TIP

BUMPER INTERFACE

FRICION SURFACE

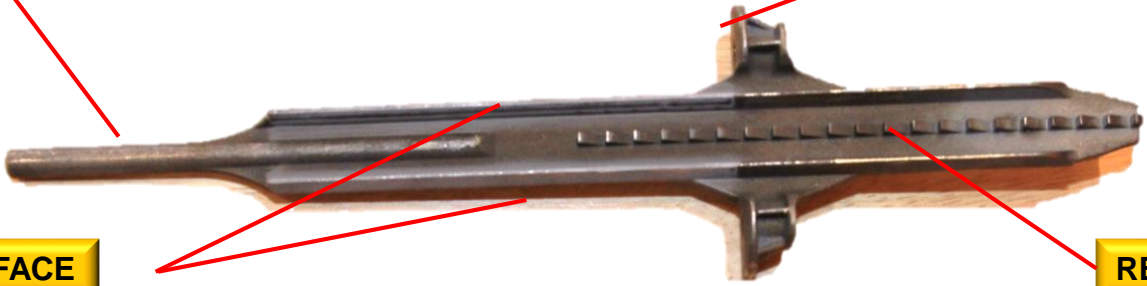

VIEW FROM UNDERSIDE

RETURN RACK

Return System – Multi Stroke Solenoid Ratchet

Operation

- Return in < 0.3 s
- 4 Strokes
- Basic Engineering

Analysis / Testing

- Dynamic simulations
- Rig test at 55K... running
- Extreme temp, low voltage
- End-user validation on framer

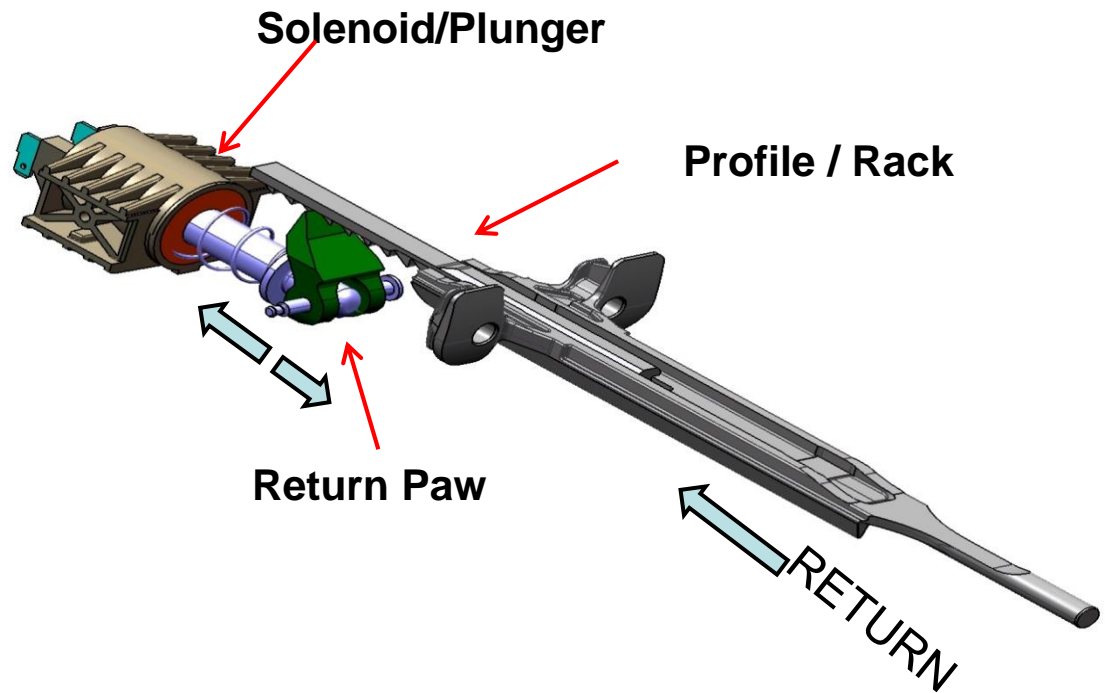

ENGINEERING – BUMPERS



LOWER BUMPERS



UPPER BUMPERS

ENGINEERING – MOTOR

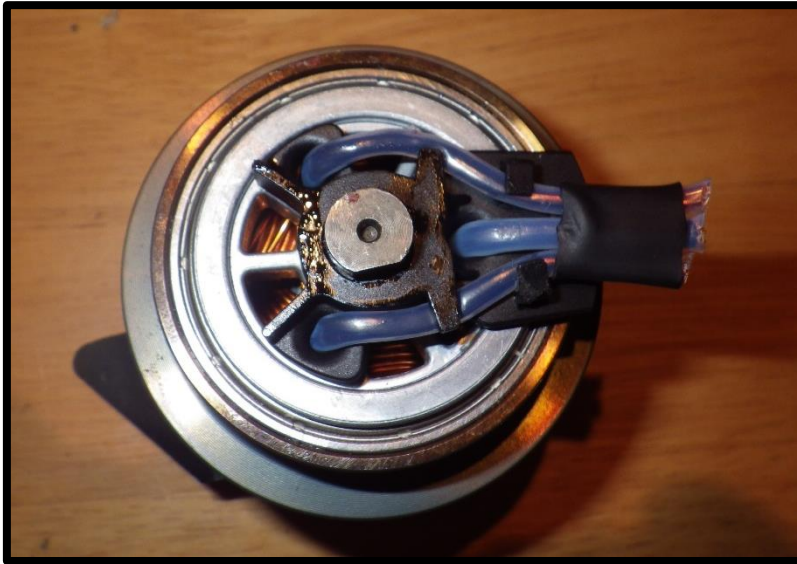









Speed Control

SPEED 1: 13,000 RPM Fastening Steel/Wood to low strength Masonry or Block (<4000 PSI) Typically 19-25mm







SPEED 2: 14,000 RPM Fastening Steel/Wood to high strength Masonry or Block (>4000 PSI) Typically 19-29mm

SPEED 3: 15,000 RPM Fastening Structural Steel/Concrete 13-57mm

	ENGLISH	GERMAN	ITALIAN	FRENCH	SPANISH	PORTUGUESE	DUTCH
	CHECK	ÜBERPRÜFEN	CONTROLLARE	CONTROLLER	COMPROBAR	VERIFIQUE	CONTROLEREN
	ATTENTION !	ACHTUNG !	ATTENZIONE !	ATTENTION !	ATENCION !	ATENÇÃO!	ATTENTIE !
	TURN COUNTER CLOCKWISE	DREHEN GEGEN UHRZEIGERSINN	GIRARE IN SENSO ANTIORARIO	TOURNEZ DANS LE SENS INVERSE DES AIGUILLES D'UNE MONTRE	GIRO IZQUIERDA	GIRAR SENTIDO ANTI- HORARIO	DRAAI LINKSOM
	TURN CLOCKWISE	DREHEN IN UHRZEIGERSINN	GIRARE IN SENSO ORARIO	TOURNEZ DANS LE SENS DES AIGUILLES D'UNE MONTRE	GIRO DERECHA	GIRAR NO SENTIDO HORARIO	DRAAI RECHTSOM
	MOVE IN THIS DIRECTION	IN RICHTUNG BEWEGEN	MUOVI IN DIREZIONE	BOUFEZ DANS CETTE DIRECTION	DIRECION DE LA FLECHA	AVANÇAR NESSA DIREÇÃO	BEWEEG IN DE RICHTING VAN DE PIJL
	CORRECT	RICHTIG	CORRETTO	CORRECT	CORRECTO	CORRECTO	GOED
	NOT CORRECT	NICHT RICHTIG	NON CORRETTO	INCORRECT	NO ES CORRECTO	NÃO É CORRECTO	FOUT
	LIFT OVER	ANHEBEN	SOLLEVARE	SOULEVEZ	LEVANTAR	LEVANTAR SOBRE A	OPHEFFEN

	ENGLISH	GERMAN	ITALIAN	FRENCH	SPANISH	PORTUGUESE	DUTCH
	PUSH	DRÜCKEN	PREMERE	APPUYEZ	APRETAR	EMPURRAR	DUWEN
	DISCONNECT	TRENNEN	SCOLLEGARE	DEBRANCHEZ	DESCONECTADO	DESLIGAR	ONTKOPPELEN
	ATTENTION! REMOVE NAILS	ACHTUNG NÄGEL ENTNEHMEN	ATTENZIONE RIMUOVERE I CHIODI	ATTENTION ! RETIREZ LES PROJECTILES	ATENCION! QUITAR LOS CLAVOS	ATENÇÃO! RETIRAR OS PREGOS	OPGELET ! VERWIJDER DE NAGELS
	CHECK THE CORRECT NAILS HAVE BEEN USED	ÜBERPRÜFEN DASS DIE NÄGEL KORREKT SIND	CONTROLLARE CHE I CHIODI SONO CORRETTI	VERIFIEZ QUE LES CLOUS UTILISES SOIENT CORRECTS	VER SI LOS CLAVOS USADOS SON LOS CORRECTOS	VERIFIQUE SE FORAM UTILIZADOS OS PREGOS CORRECTOS	CONTROLEER DAT DE JUISTE NAGELS GEBRUIKT WORDEN
	CHECK THE CHARGE OF THE BATTERY	LADEGERÄT ÜBERPRÜFEN	CONTROLLARE CHE LA BATTERIA SIA CARICA	VERIFIEZ LA CHARGE DE LA BATTERIE	COMPRUEBE LA CARGA DE LA BATERIA	VERIFIQUE A CARGA DA BATERIA	CONTROLEER DE BATTERIJ

	ENGLISH	GERMAN	ITALIAN	FRENCH	SPANISH	PORTUGUESE	DUTCH
	LUBRICATION	BEFETTEN	LUBRIFICAZIONE	LUBRIFICATION	ENGRASE	LUBRIFICAÇÃO	SMERING
	HEX KEY SIZE	GRÖSSE INNENSECHSKANT-SCHLÜSSEL	DIMENSIONE VITE ESAGONALE	TAILLE SIX PAN	TAMAÑO LLAVE EXAGONAL	TAMANHO CHAVE HEX	AFMETING VAN DE INBUSSLEUTEL
	SCREW THREAD SIZE AND LENGTH	SCHRAUBENKOPF GRÖSSE UND SCHRAUBENLÄNGE	CARATTERISTICHE DELLA VITE	FILETAGE DE LA VIS, DIAMETRE ET LONGUEUR	ROSCA DEL TORNILLO TAMAÑO, LONGITUD	TAMANHO DE ROSCA E COMPRIMENTO DO PARAFUSO	SCHROEFTYPE EN AFMETINGEN
	SPANNER	SCHRAUBEN-SCHLÜSSEL	CHIAVE	CLEF	LLAVE FIJA	CHAVE DE BOCAS	MOERSLEUTEL
	QUESTION ?	FRAGE?	DOMANDE ?	QUESTION ?	¿PREGUNTA?	PERGUNTA?	VRAGEN?
WWW.2HELPU.COM	GO TO WEB SITE FOR MORE INFORMATION	GEHE ZUR WEB SEITE FÜR WEITERE INFORMATIONEN	VISITARE IL SITO PER MAGGIORI INFORMAZIONI	ALLEZ SUR NOTRE SITE POUR PLUS D'INFORMATION	VISITA LA PAGINA WEB PARA MAS INFORMACION	PARA MAIS INFORMAÇÕES VISITE PAGINA WEB	GA NAAR ONZE WEBSITE VOOR MEER INFORMATIE

	ENGLISH	GERMAN	ITALIAN	FRENCH	SPANISH	PORTUGUESE	DUTCH
	ACTIVATE	SCHIESSEN	SPARARE	ACTIVEZ	ACTIVAR	ACTIVAR	SCHIETEN
	CLEANING MACHINE	WASCH MASCHINE	LAVAPEZZI	BAC DE LAVAGE	MAQUINA DE LIMPIEZA	MÁQUINA DE LIMPEZA	WASMACHINE
	FUNCTION TEST	FUNKTIONSTEST DURCHFÜHREN	ESEGUIRE IL TEST	TEST FONCTIONNEL	PRUEVA DE FUNCIONAMIENTO	TESTE DE FUNCIONAMENTO	FUNCTIETEST
	NUMBER OF NAILS FIRED	ANZAHL DER VERSCHOSSENE N NÄGEL	CHIODI SPARATI	NOMBRE DE CLOUS TIRES	NUMERO DE CLAVOS DISPARADOS	NÚMERO DE PREGOS DISPARADOS	AANTAL AFGEVUURDE NAGELS
	CLEAN THE TOOL	GERÄT REINIGEN	PULIRE L'UTENSILE	NETTOYEZ L'OUTIL	LIMPIEZA DE HERRAMIENTAS	LIMPE A FERRAMENTA	REINIG HET TOESTEL
	SEND THE TOOL TO THE CUSTOMER	GERÄT ZUM KUNDEN SENDEN	SPEDIRE L'UTENSILE AL CLIENTE	EXPEDIEZ L'OUTIL AU CLIENT	ENVIAR LA HERRAMIENTA AL CLIENTE	ENVIAR A FERRAMENTA AO CLIENTE	VERZEND HET TOESTEL NAAR DE KLANT

Before dismantling



The CCN does have the blinking LED's to signal 1k shots. Hold the trigger for 10 - 15 seconds before the blinking will start.

Before dismantling

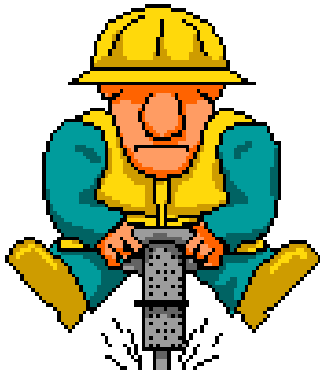

Before dismantling



Before dismantling



Charge Indicators		
	Charging	--- ---
	Fully Charged	====
	Hot/Cold Pack Delay*	--- ---

Magazine Removal

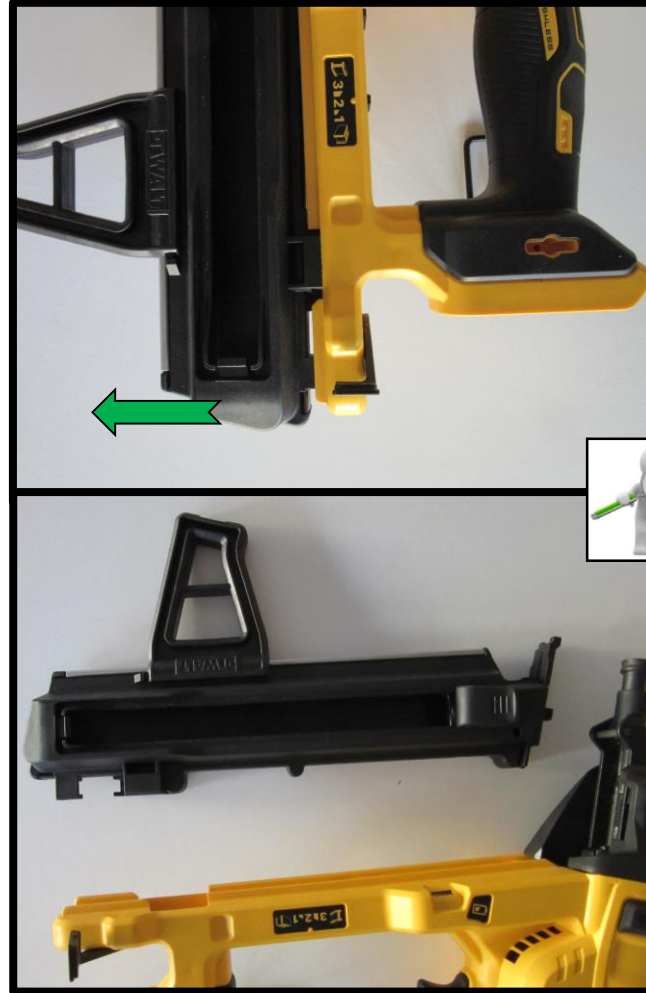

ENGINEERING – DRY FIRE LOCK OUT

TAB IS EXPOSED WHEN NO NAILS ARE IN MAGAZINE

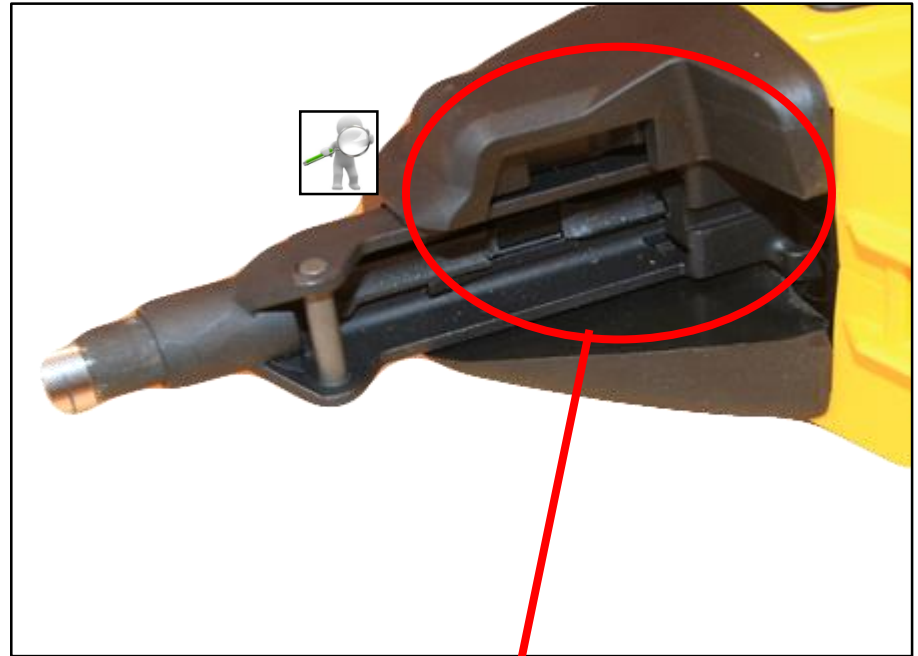

TAB ENGAGES INTO CONTACT TRIP AND STOPS MOVEMENT

Profile Removal

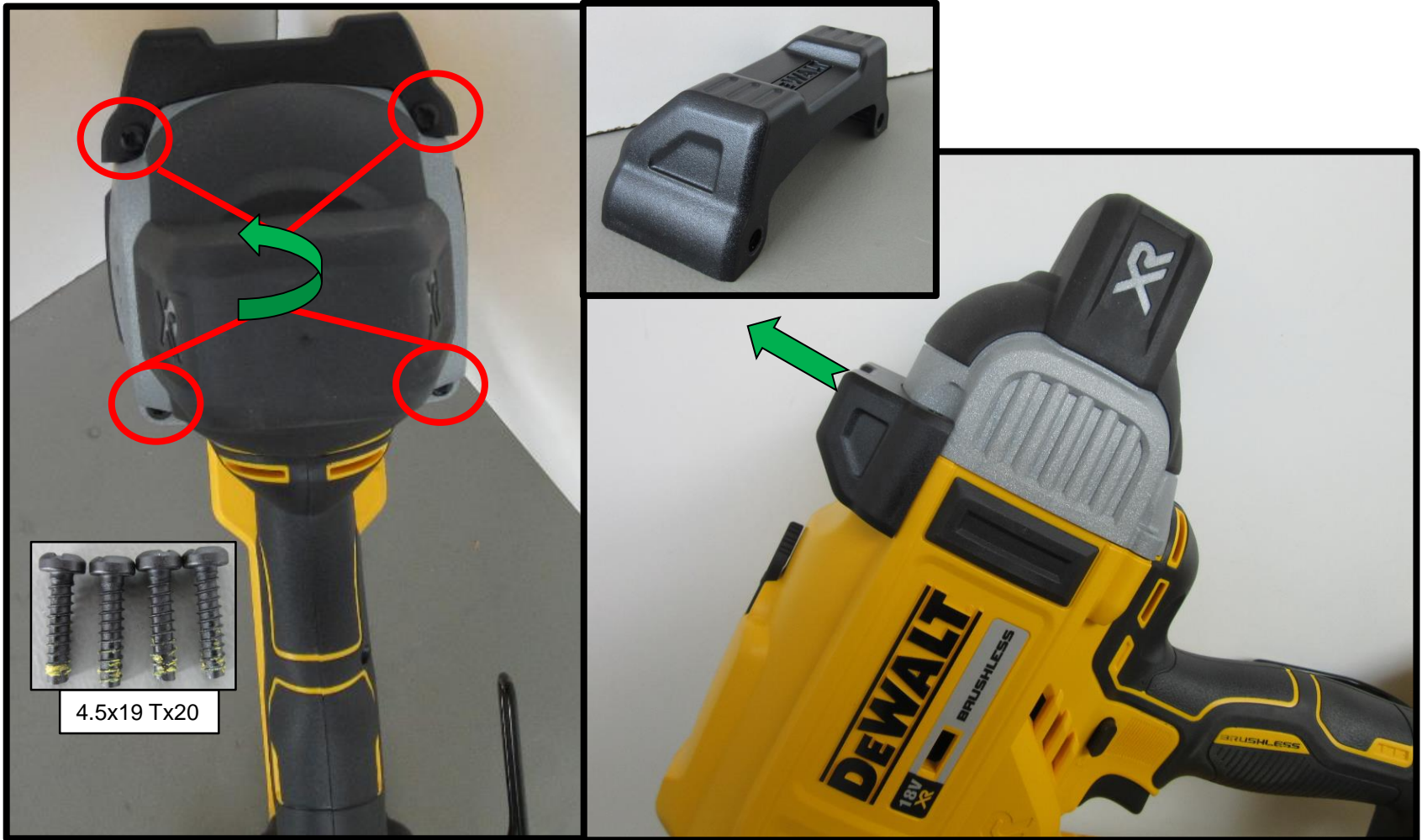

Profile Removal



Profile Removal

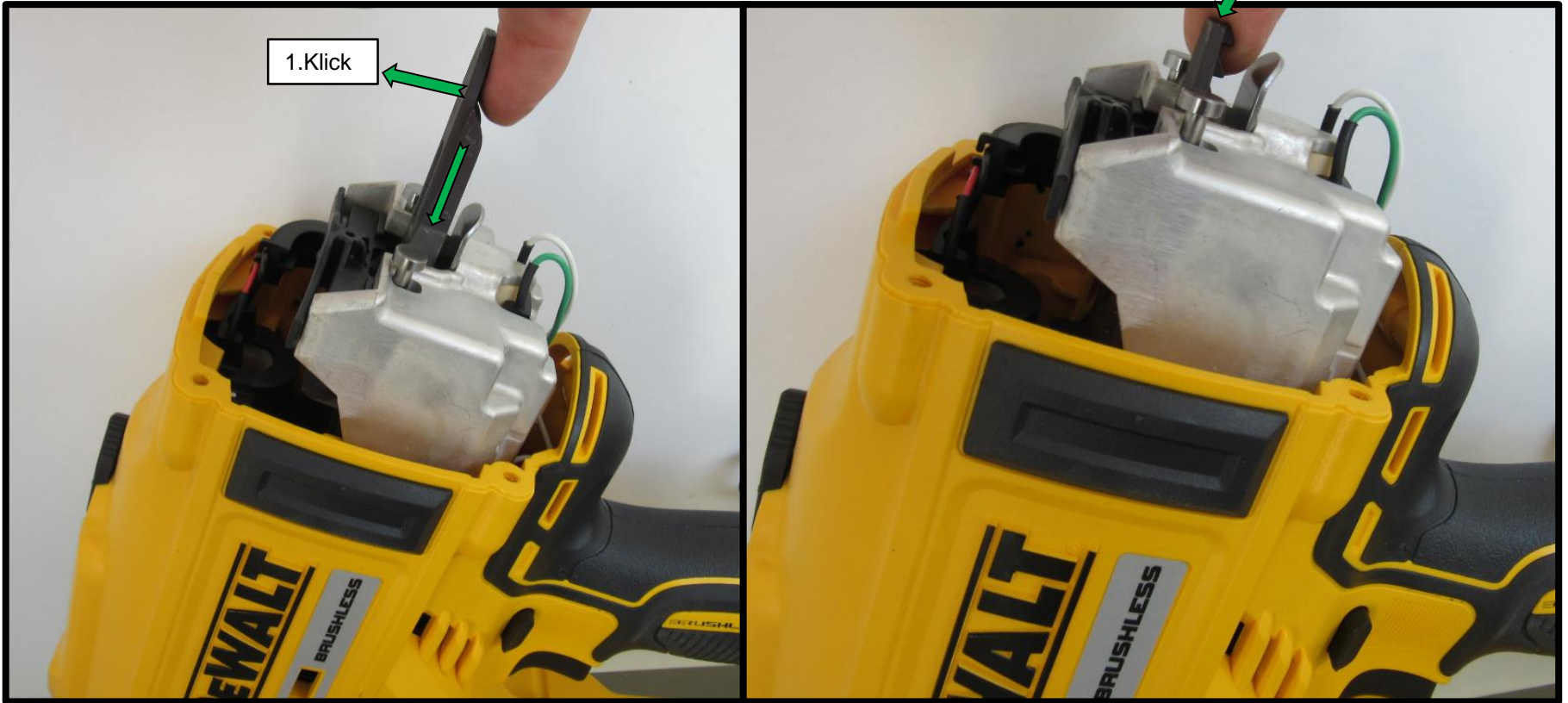

Profile Removal

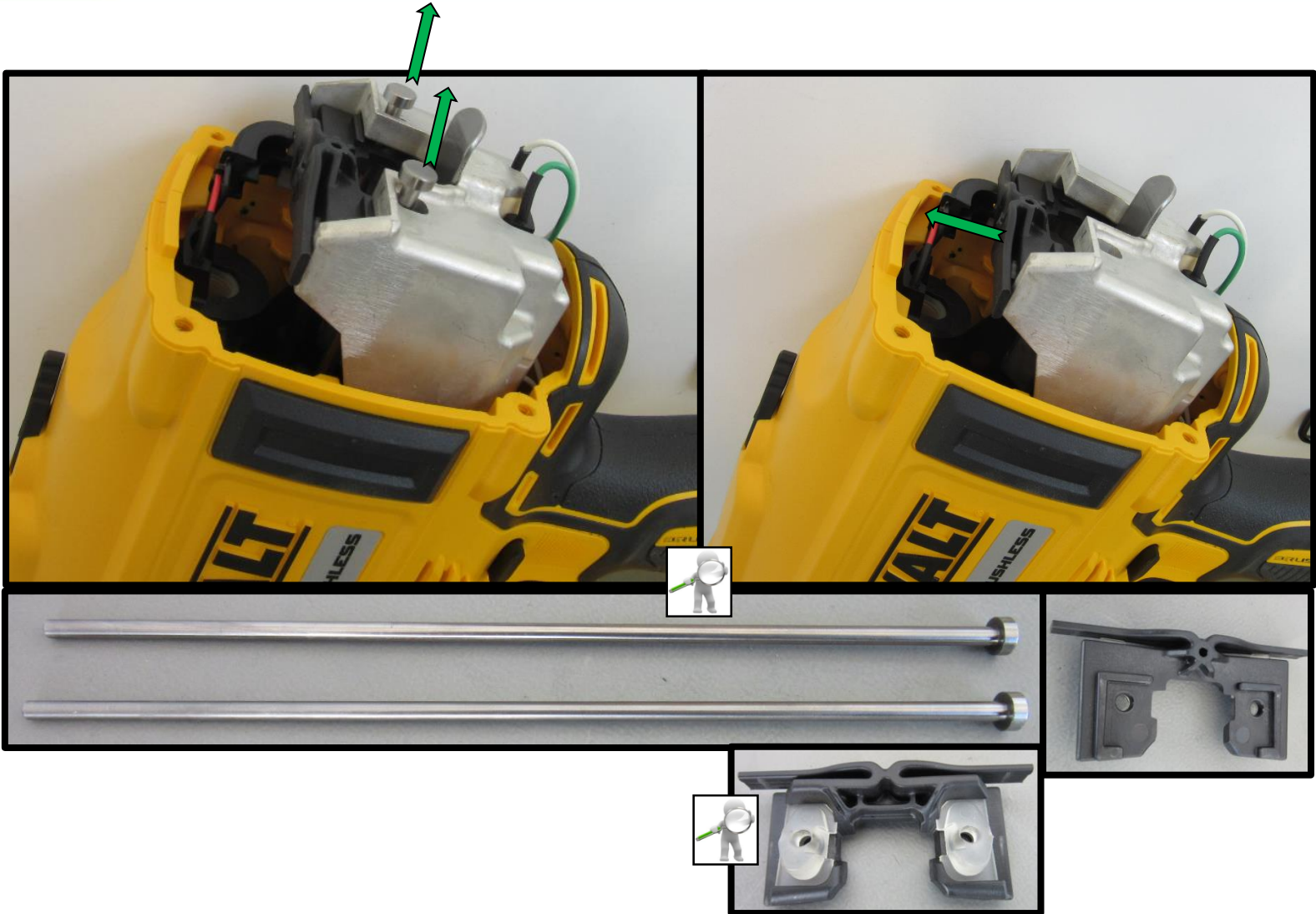

Profile Removal

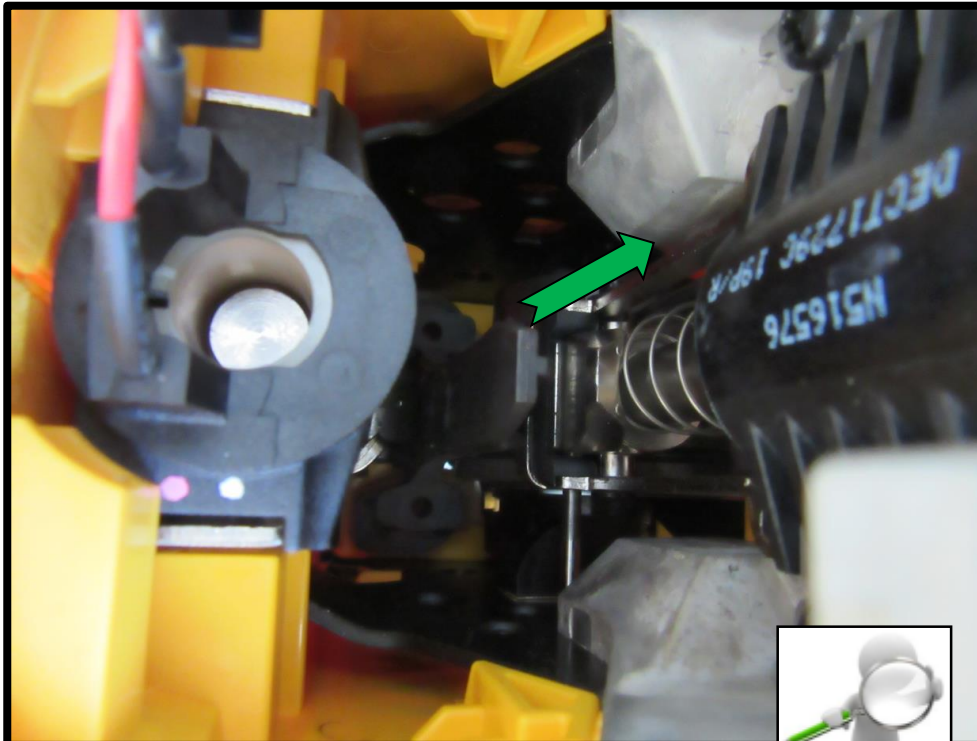

Disassembling procedure

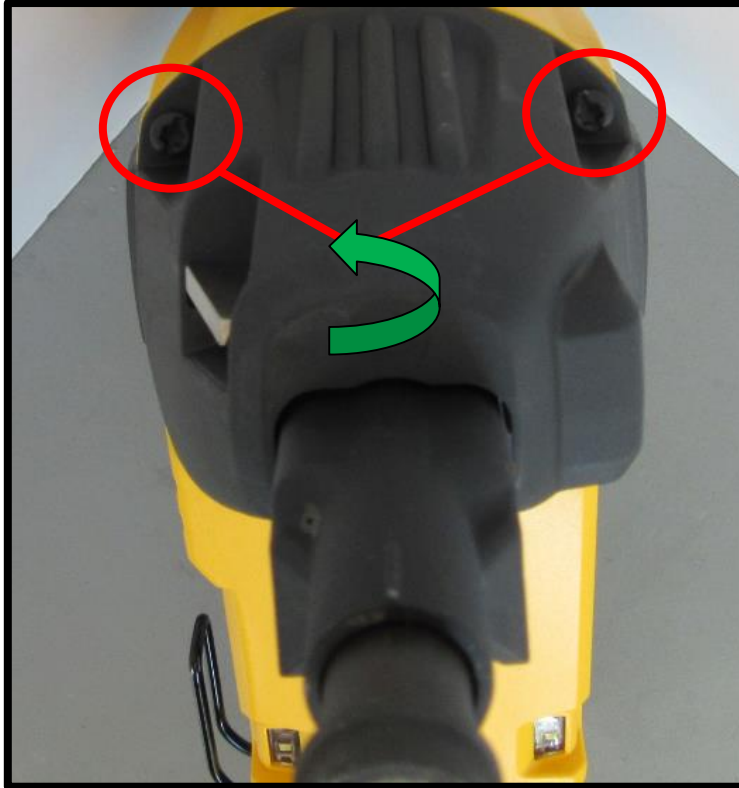

Disassembling procedure

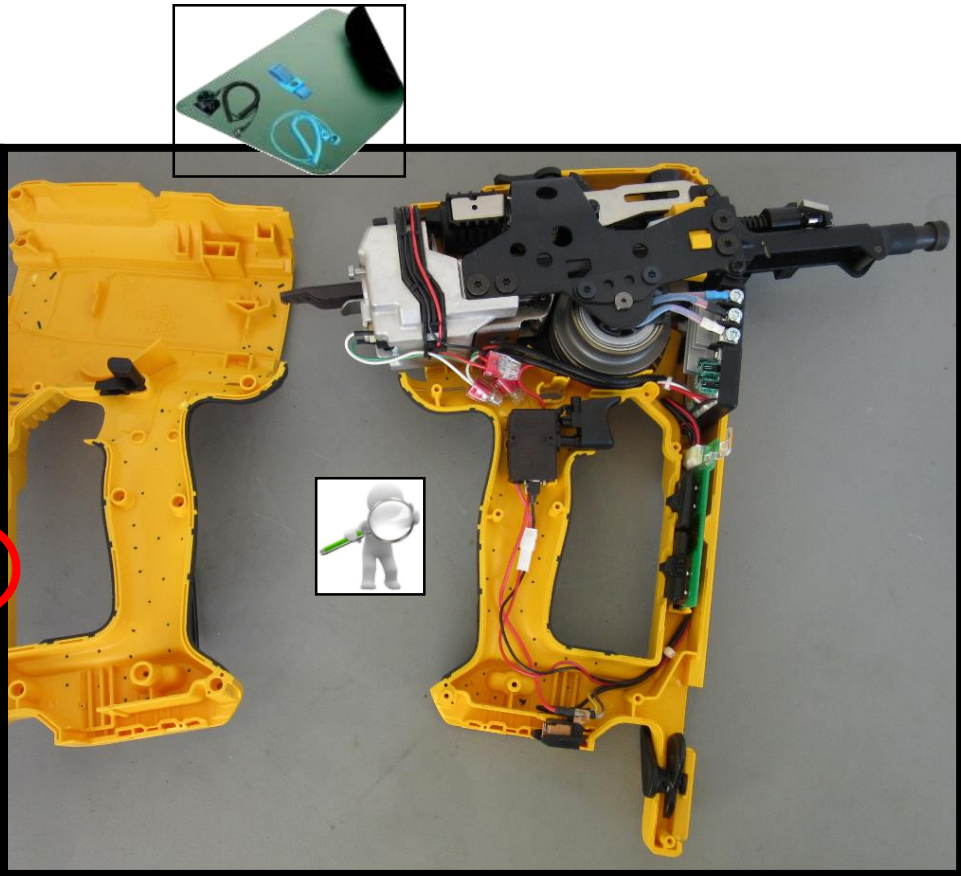

Wiring and connection

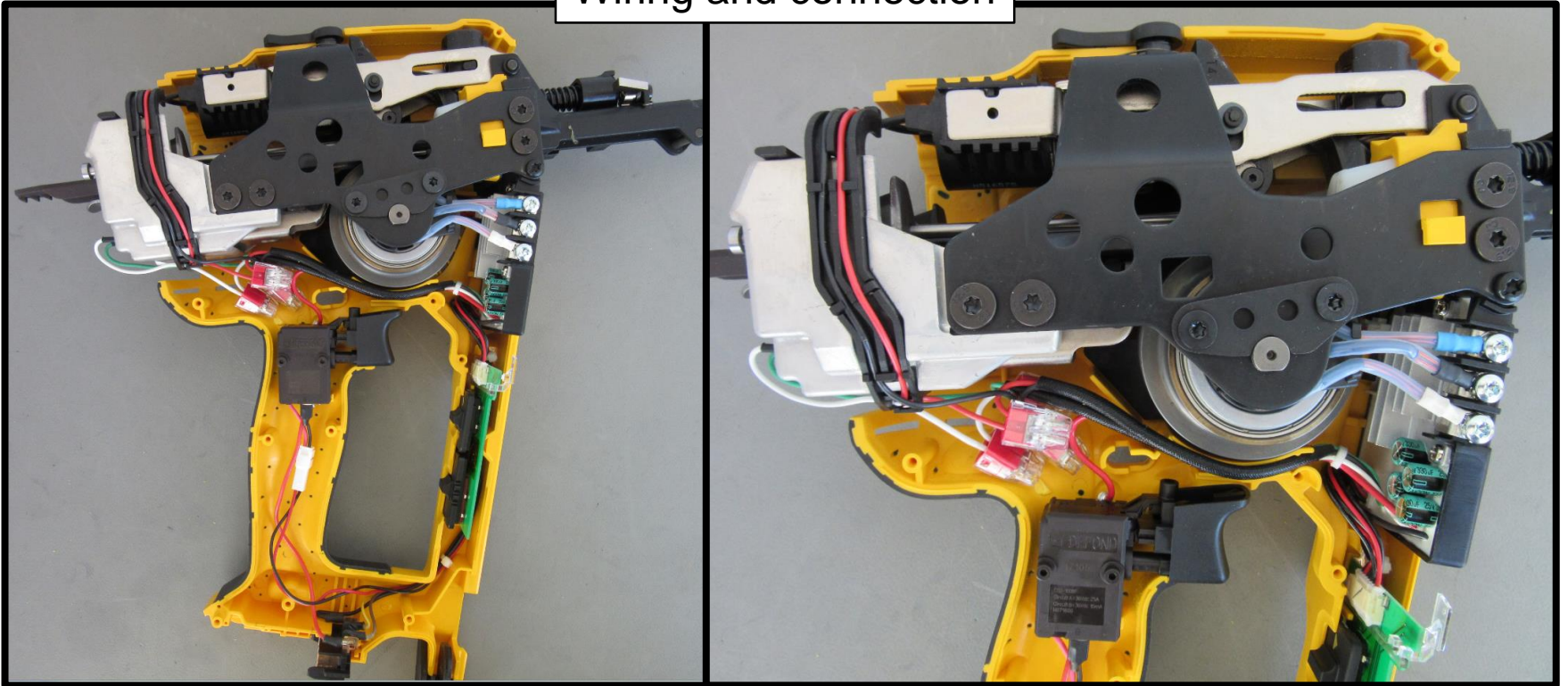

Wiring and connection

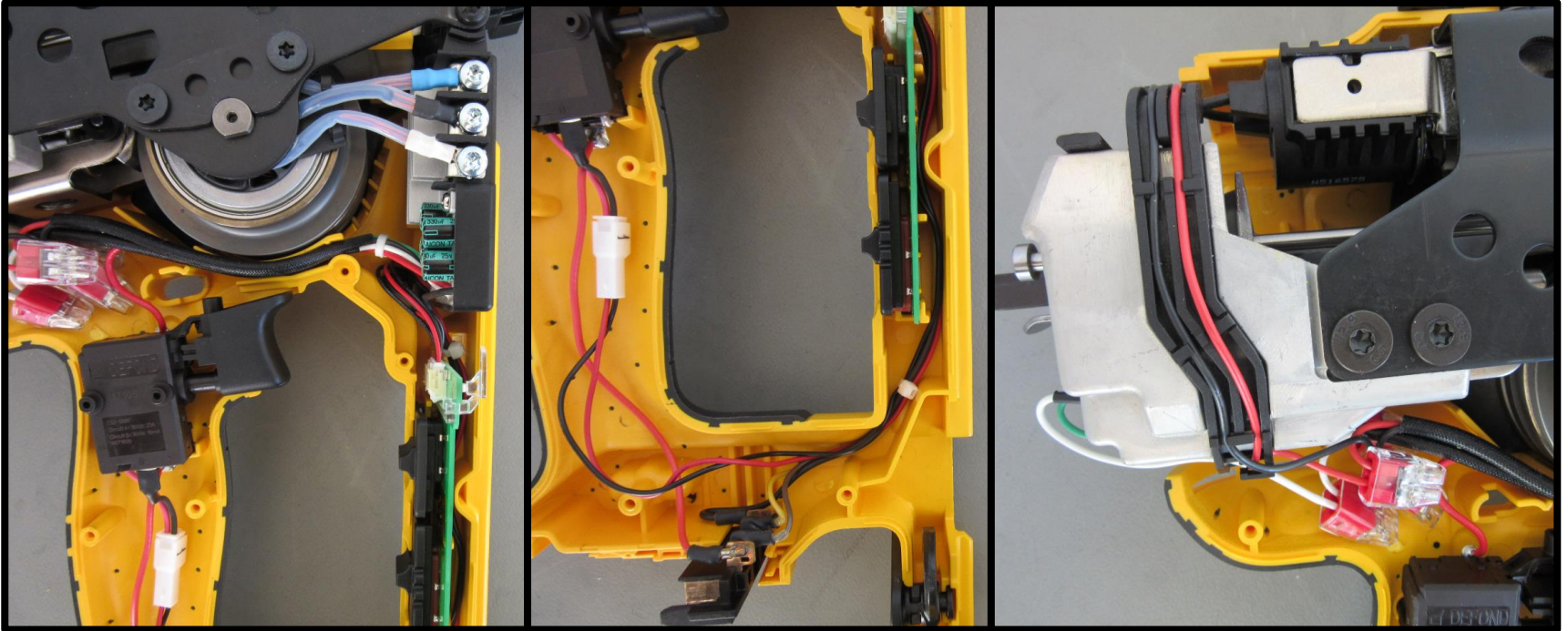

Disassembling procedure

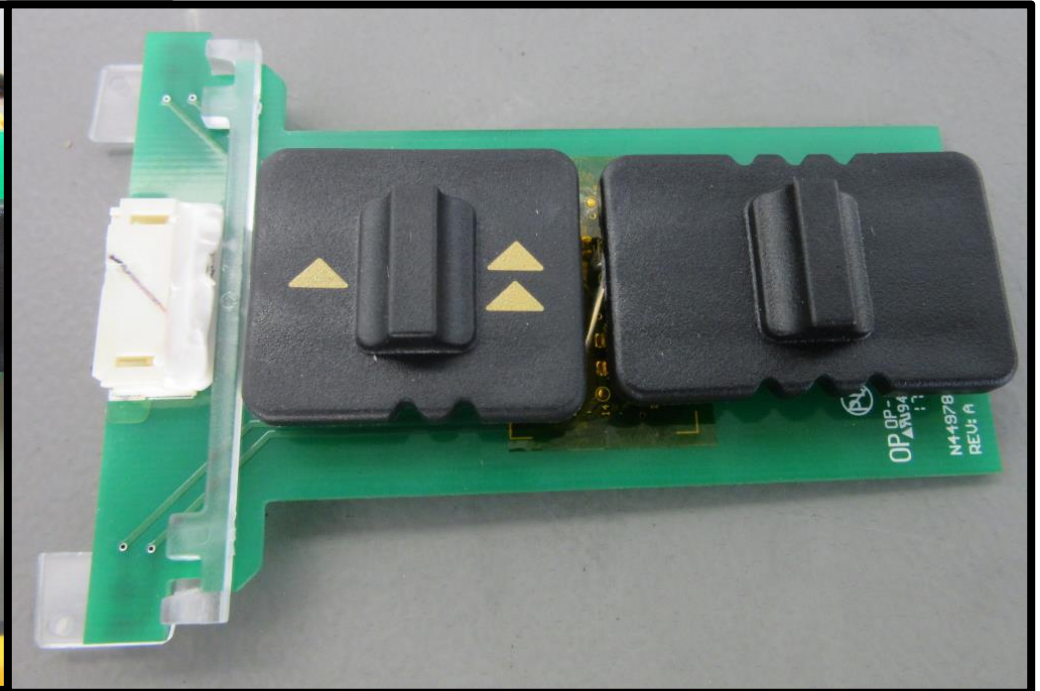
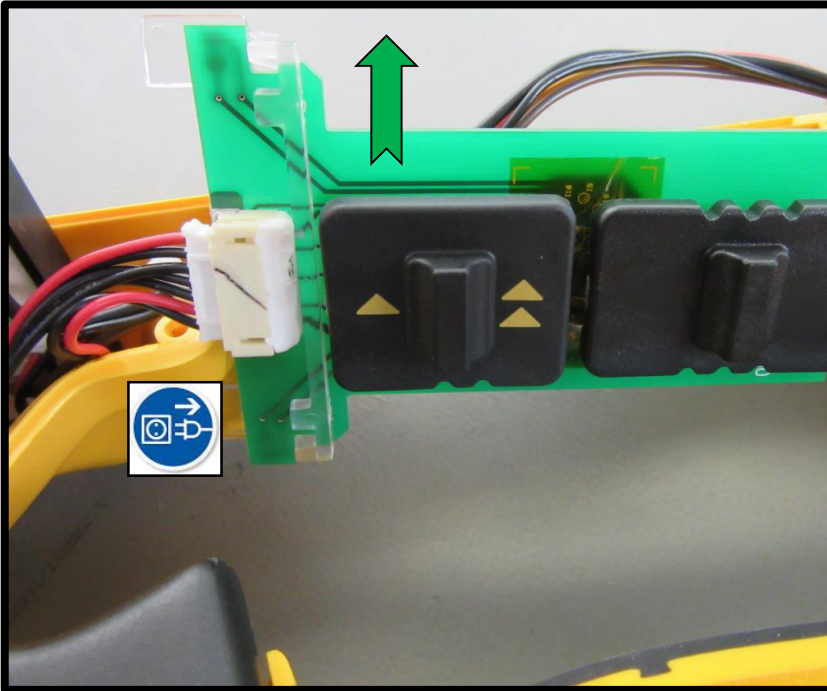

Disassembling procedure

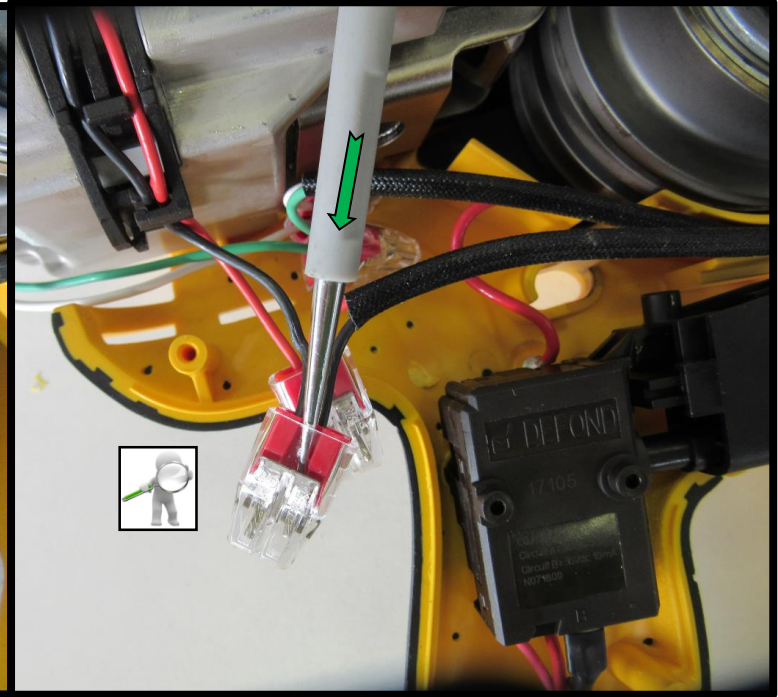
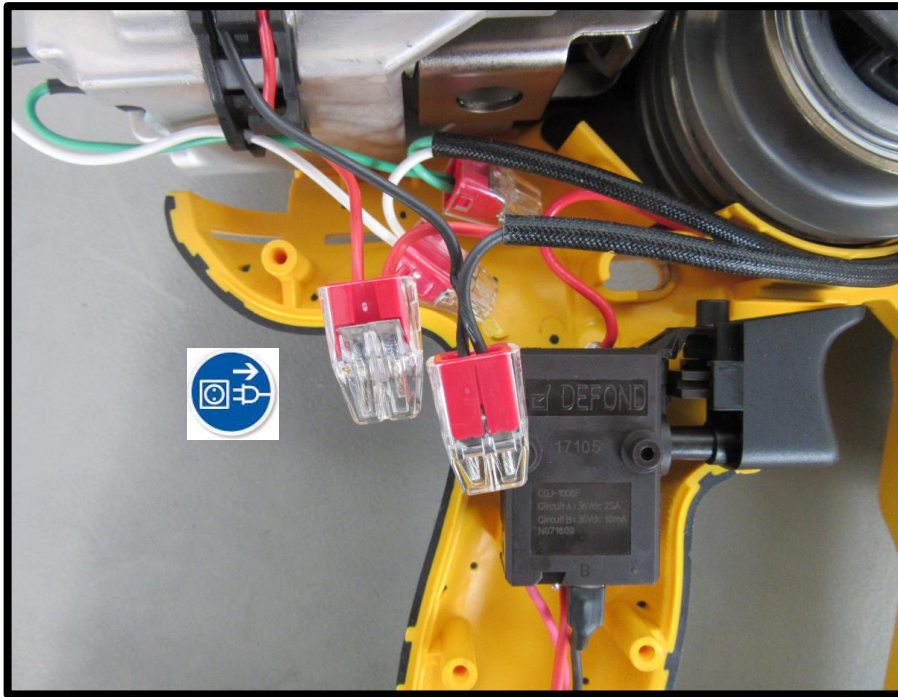

Disassembling procedure

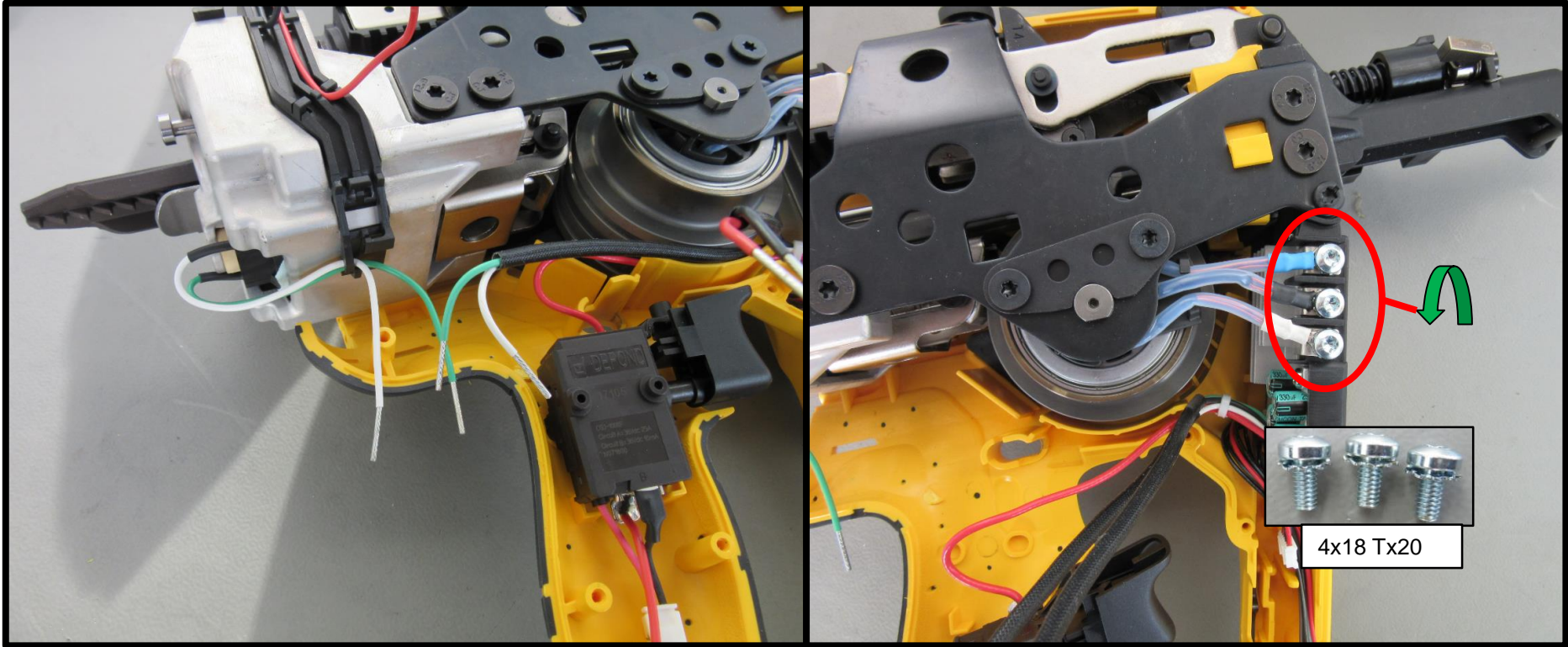

Disassembling procedure

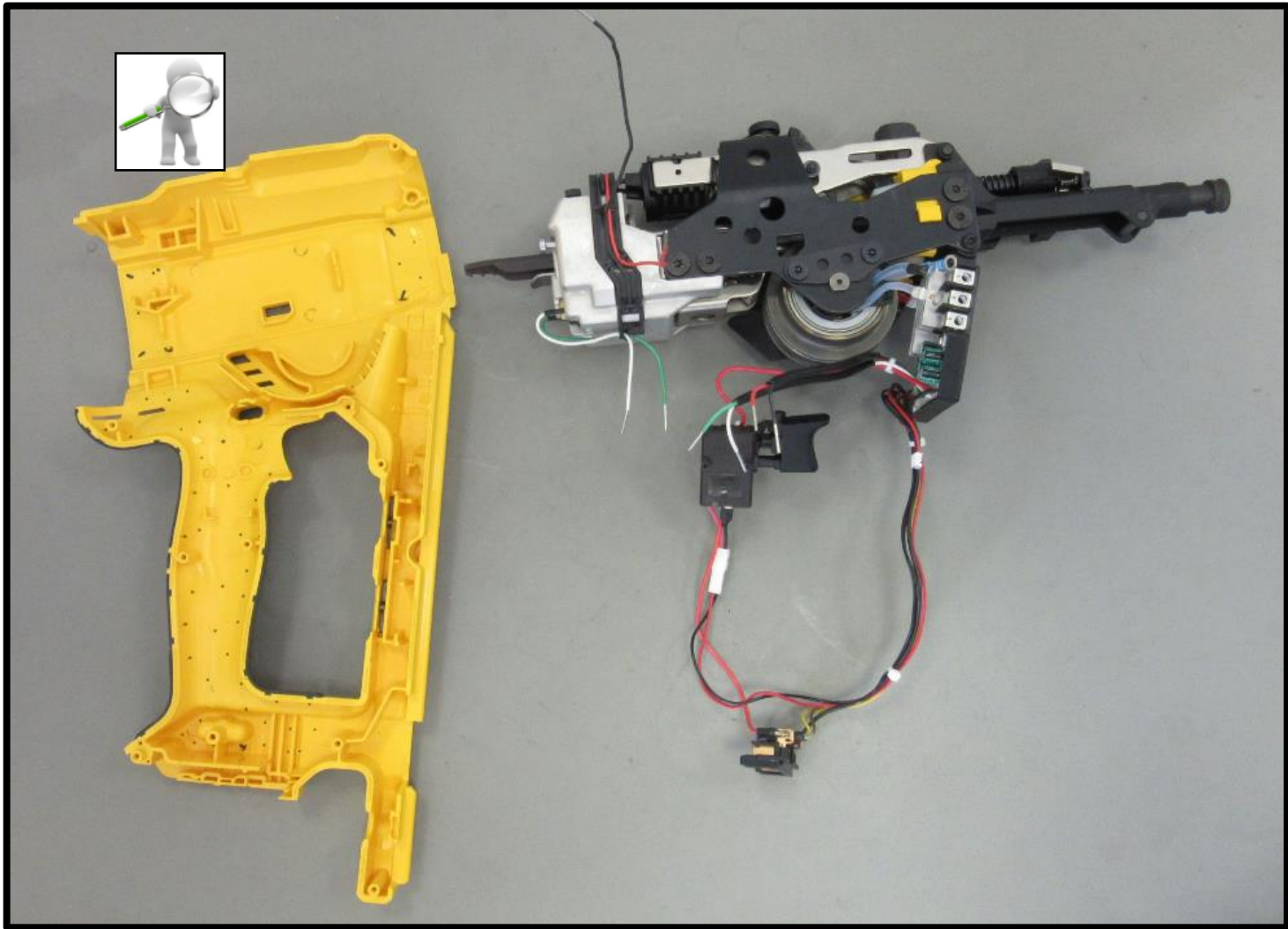

Disassembling procedure

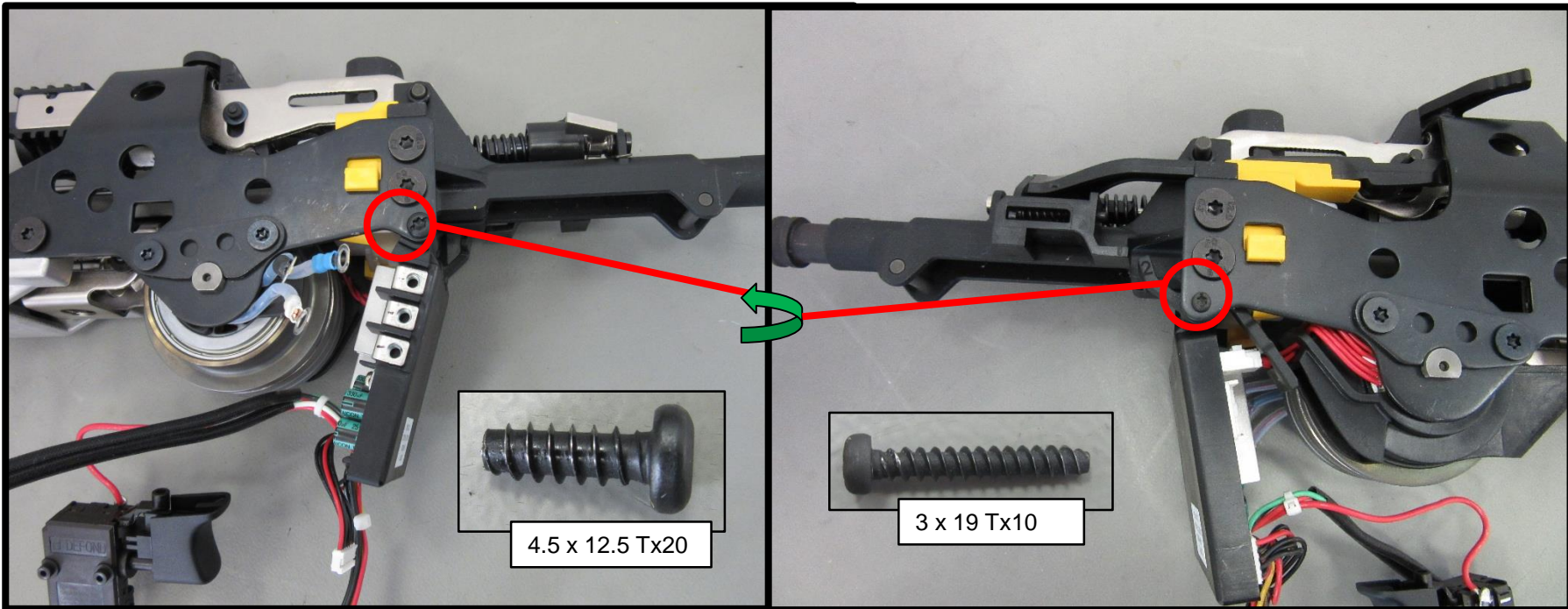

Disassembling procedure

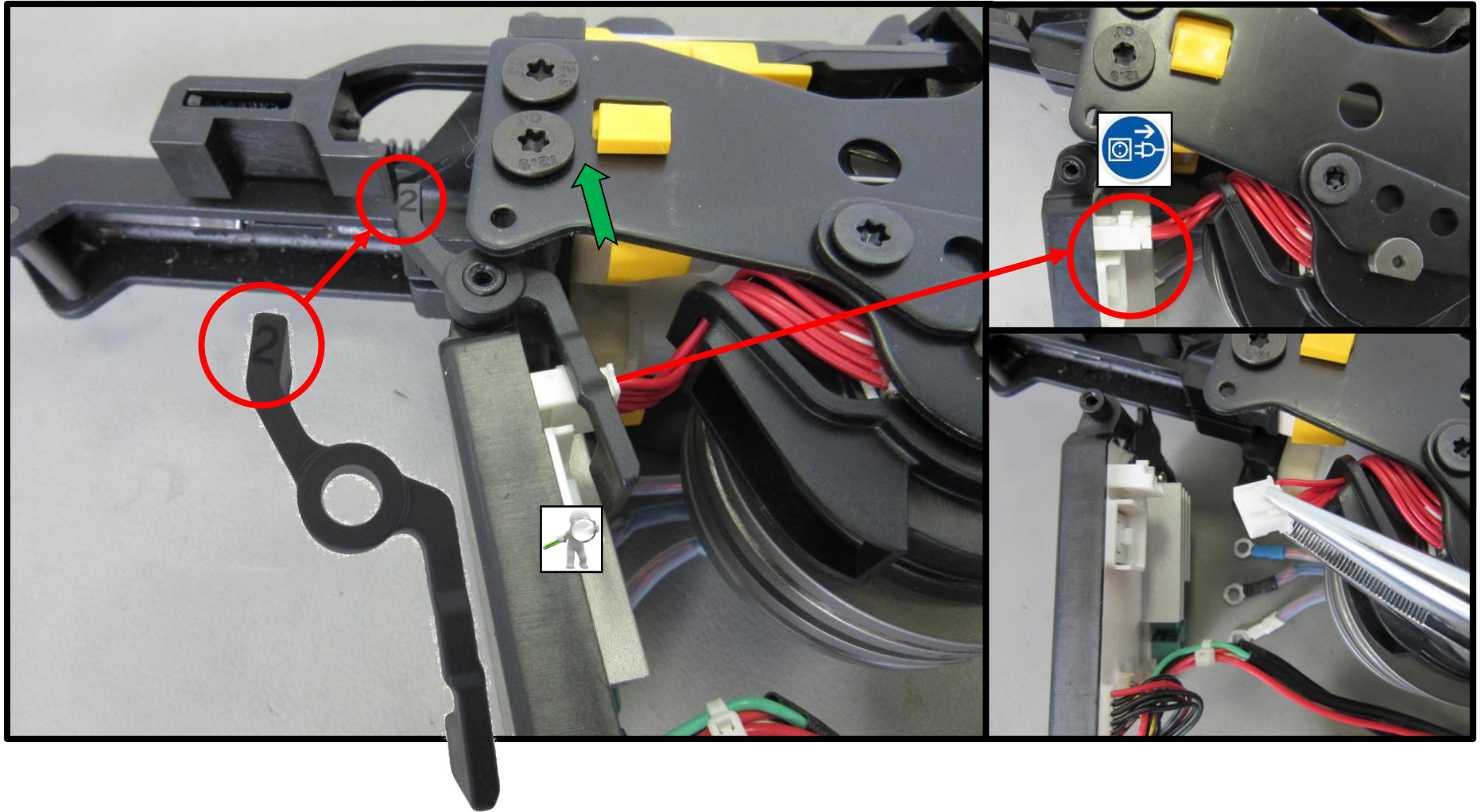

Disassembling procedure

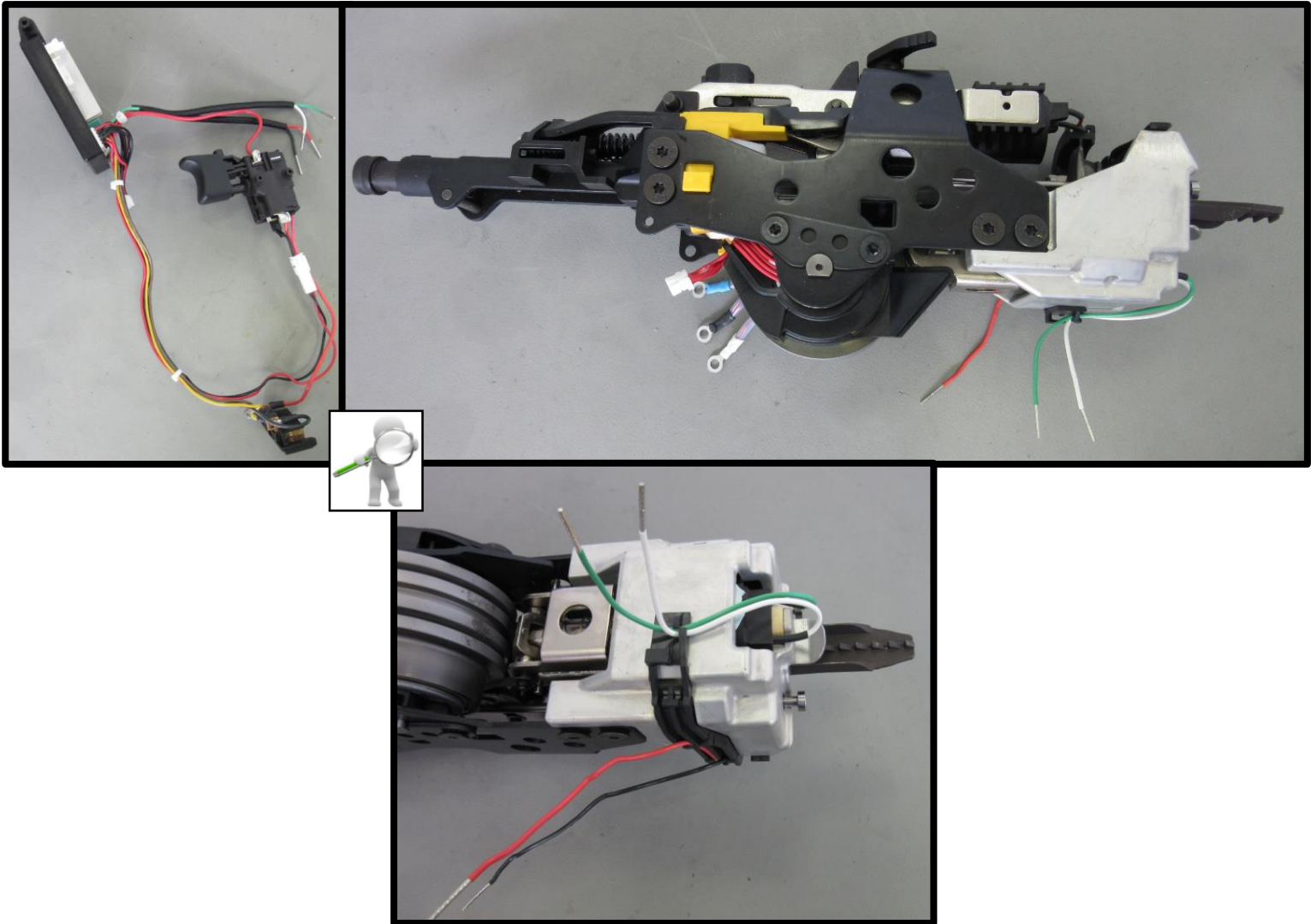

Disassembling procedure

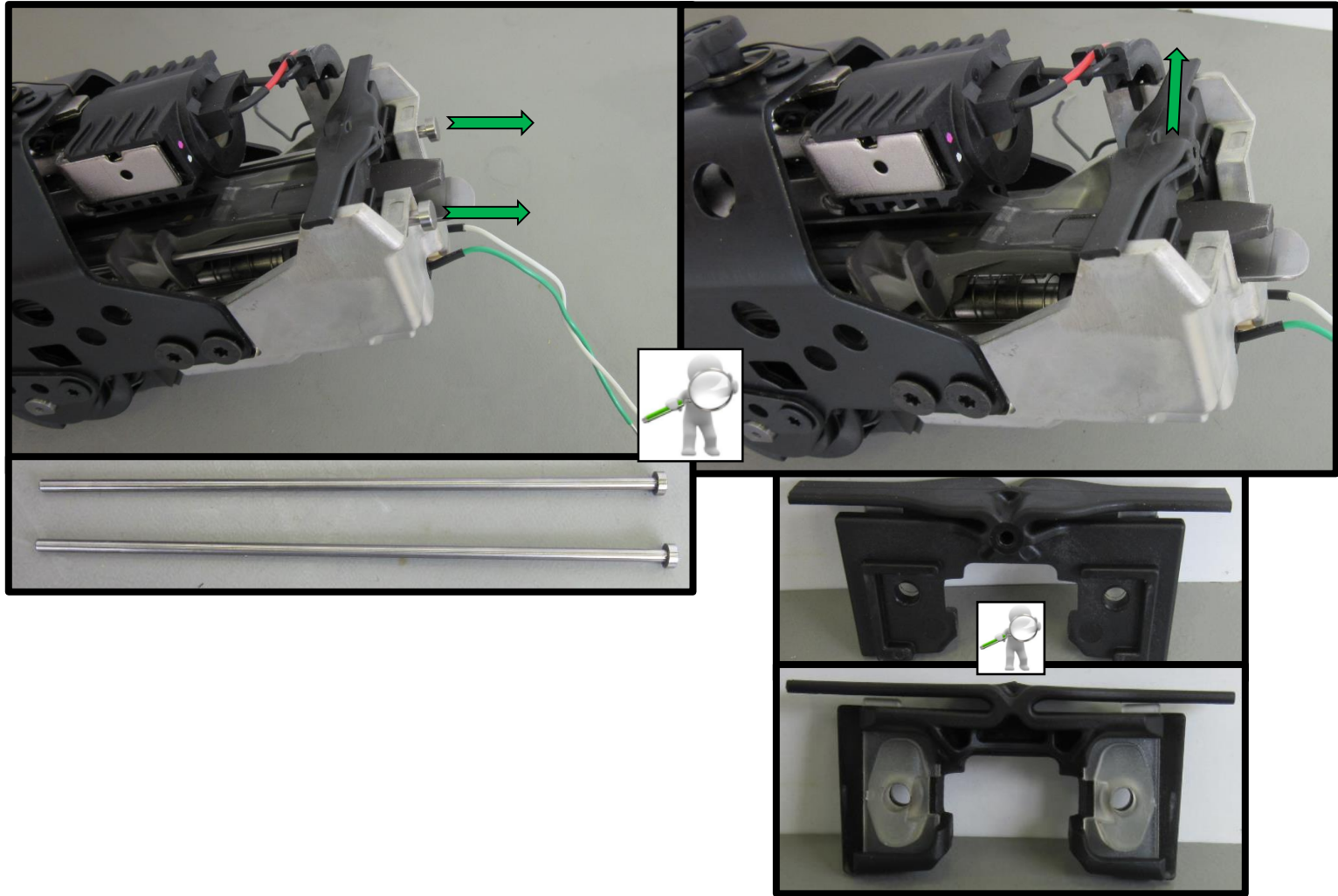

Disassembling procedure

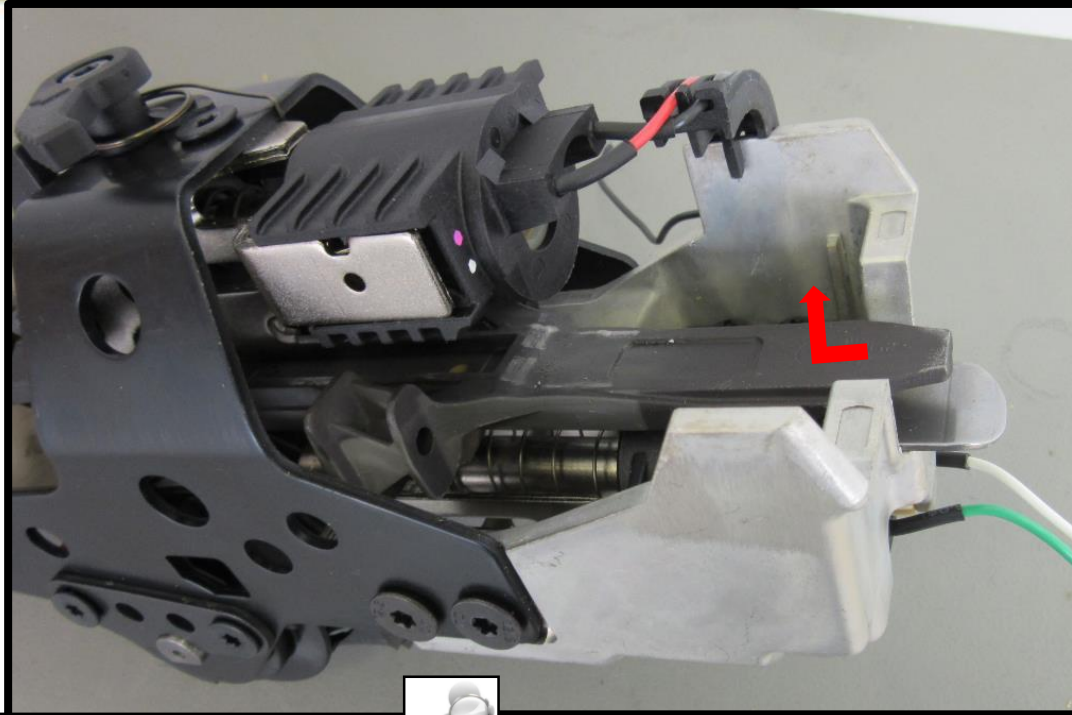

Disassembling procedure

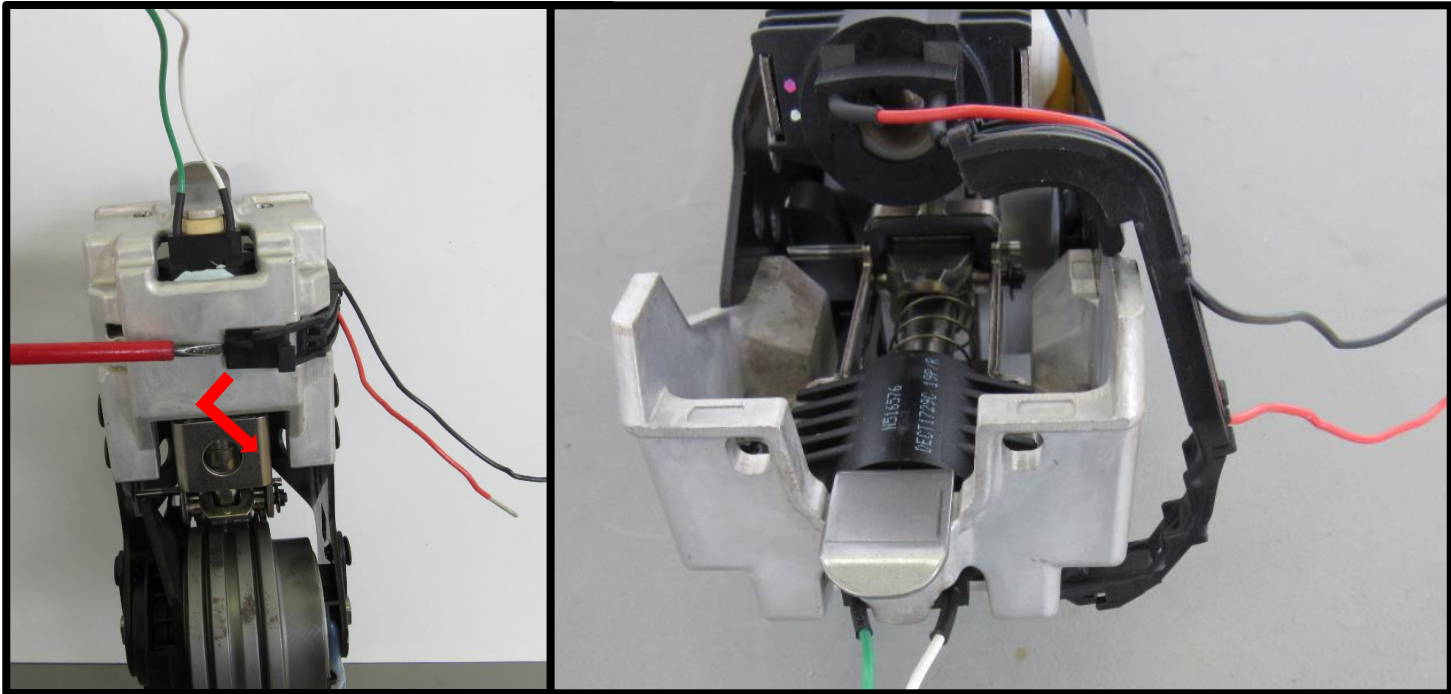

Disassembling procedure

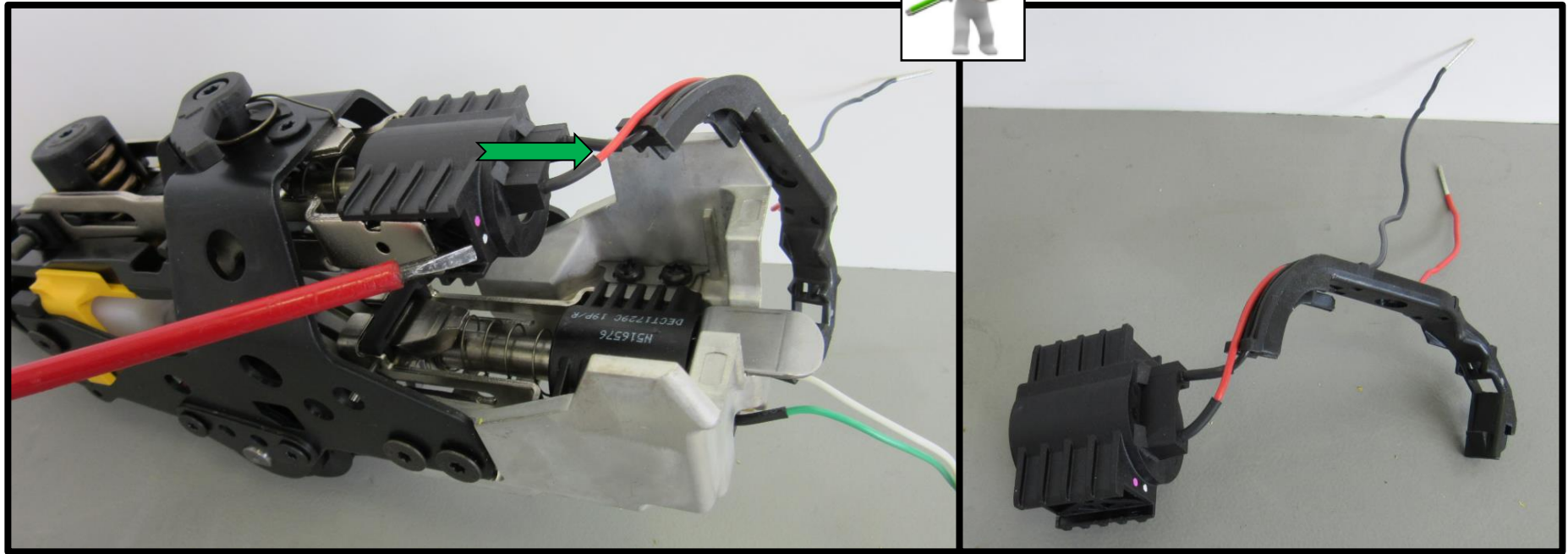
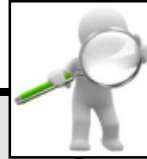

Disassembling procedure

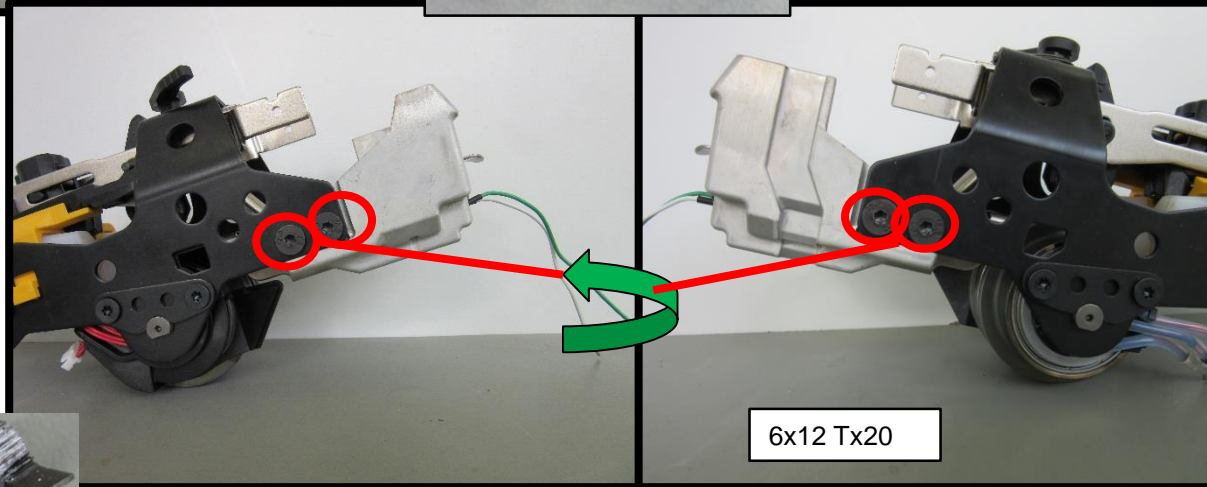
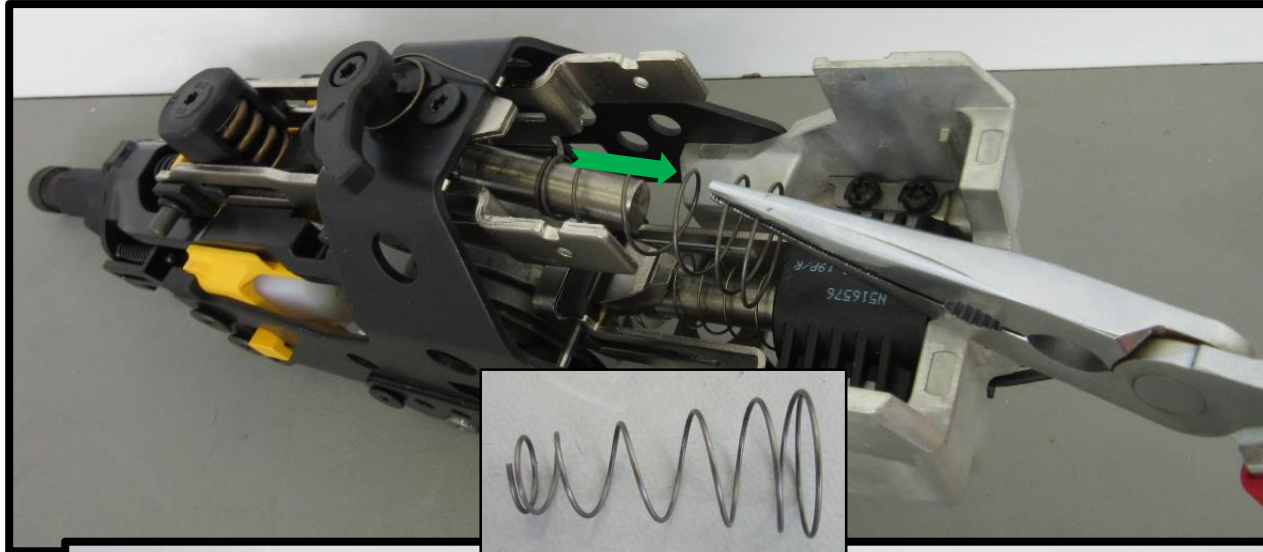

Disassembling procedure

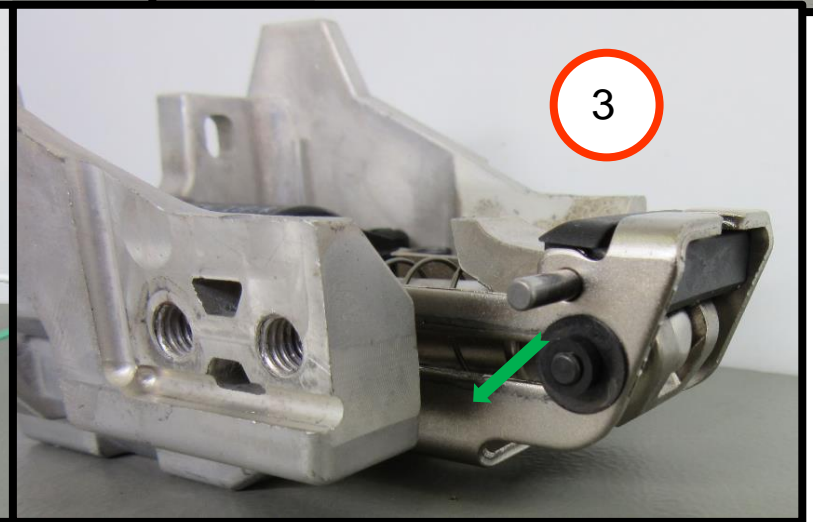
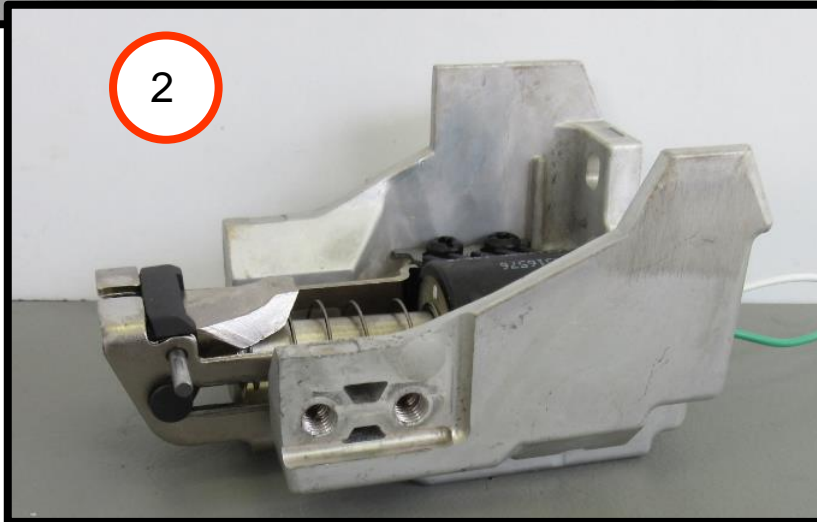
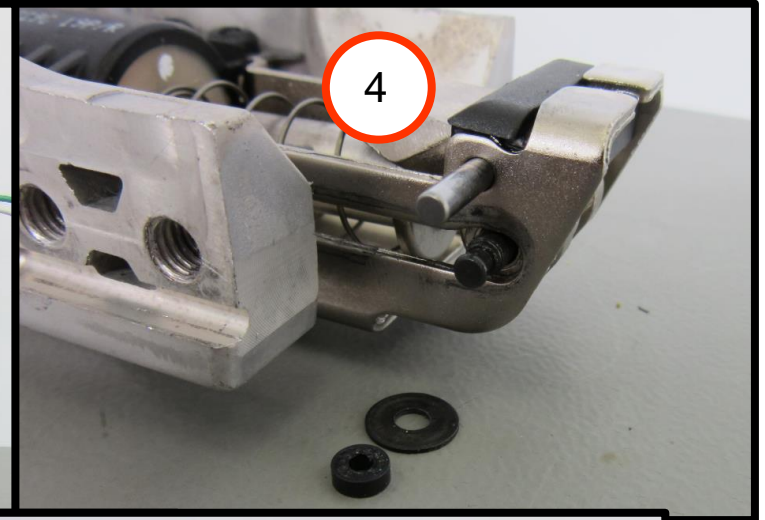
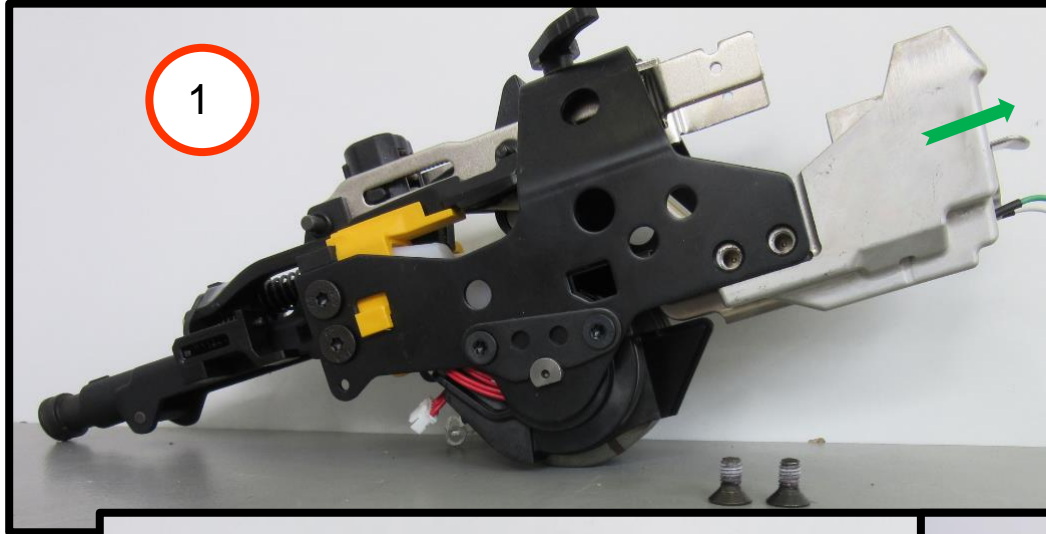

Disassembling procedure

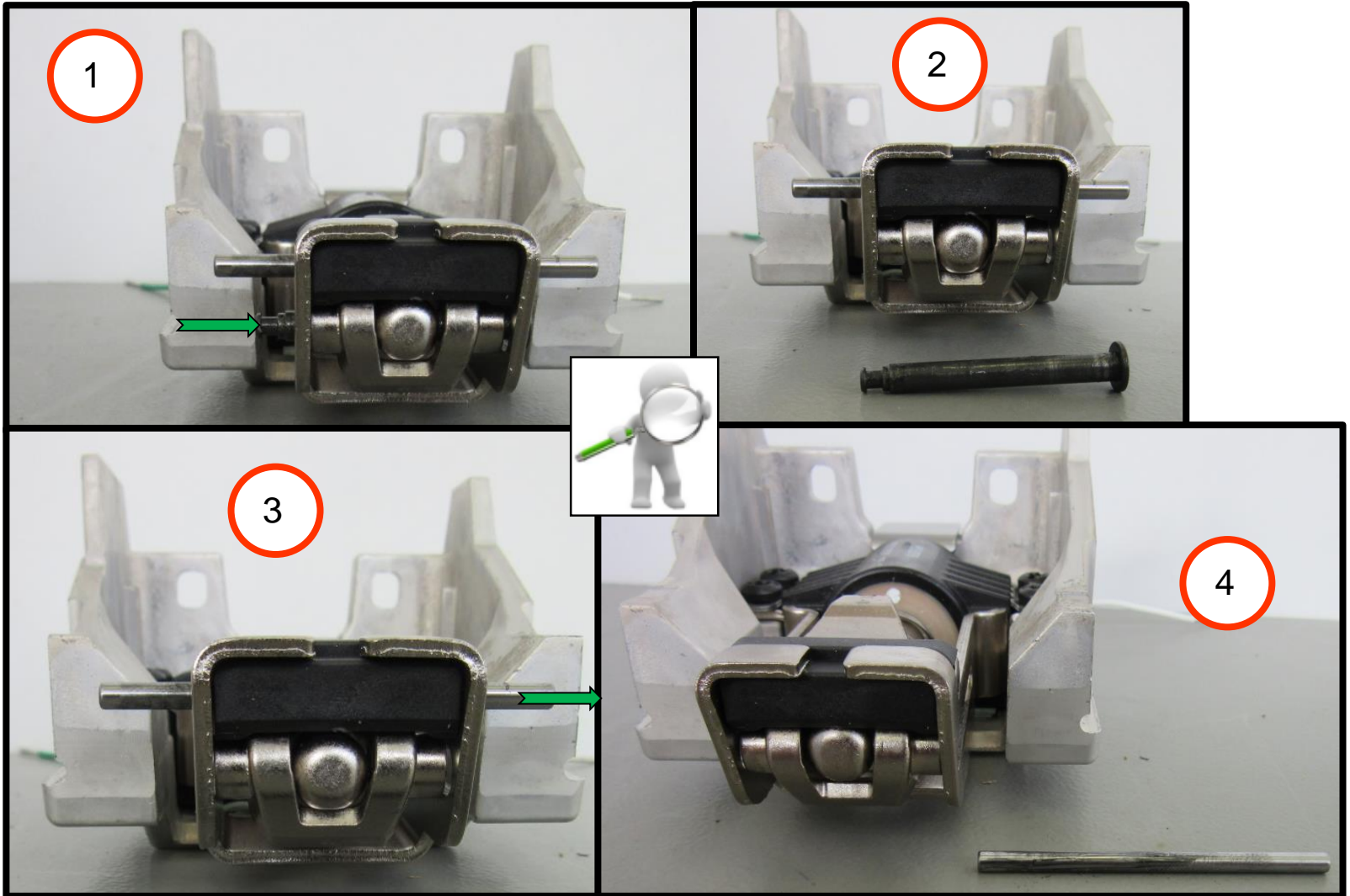

Disassembling procedure

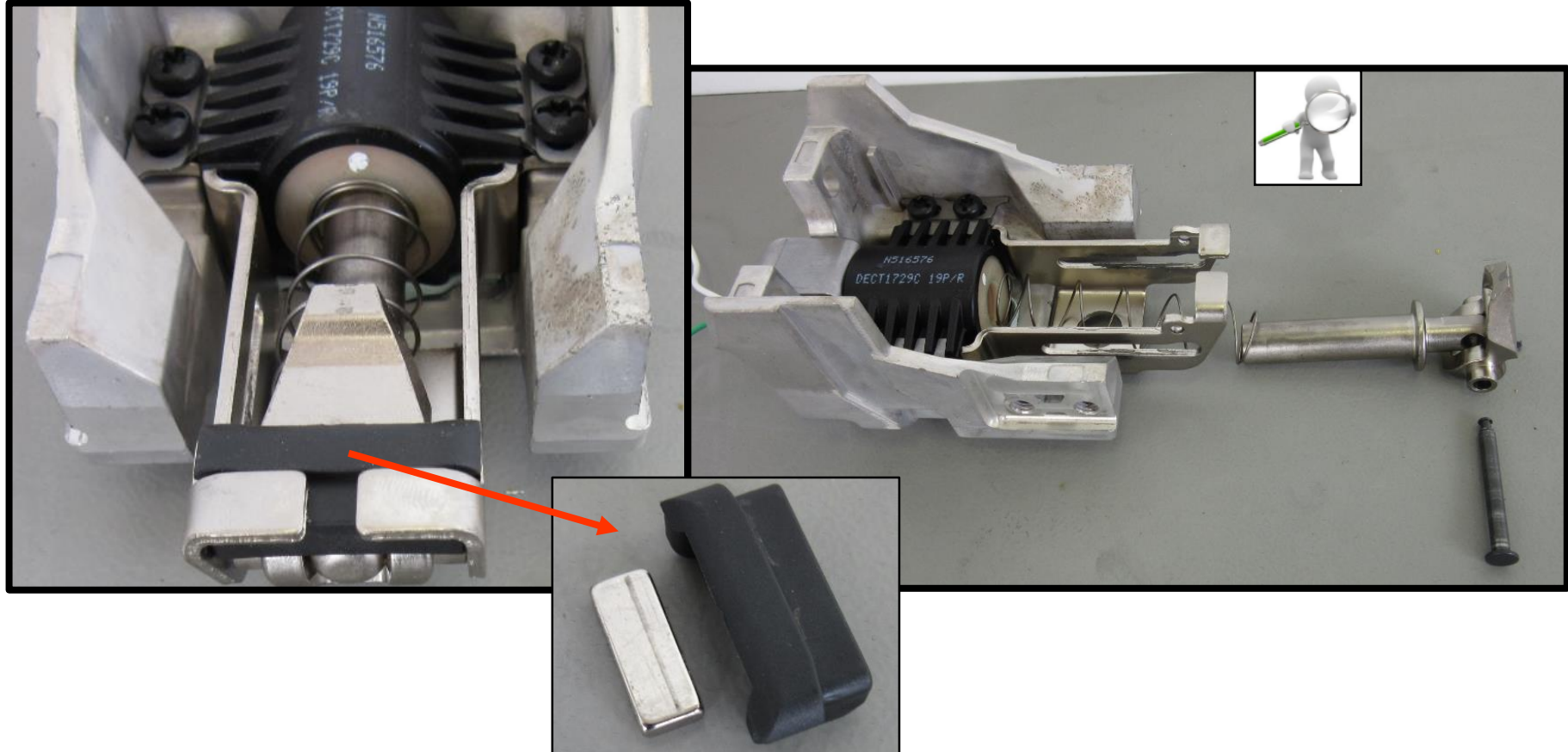

Disassembling procedure

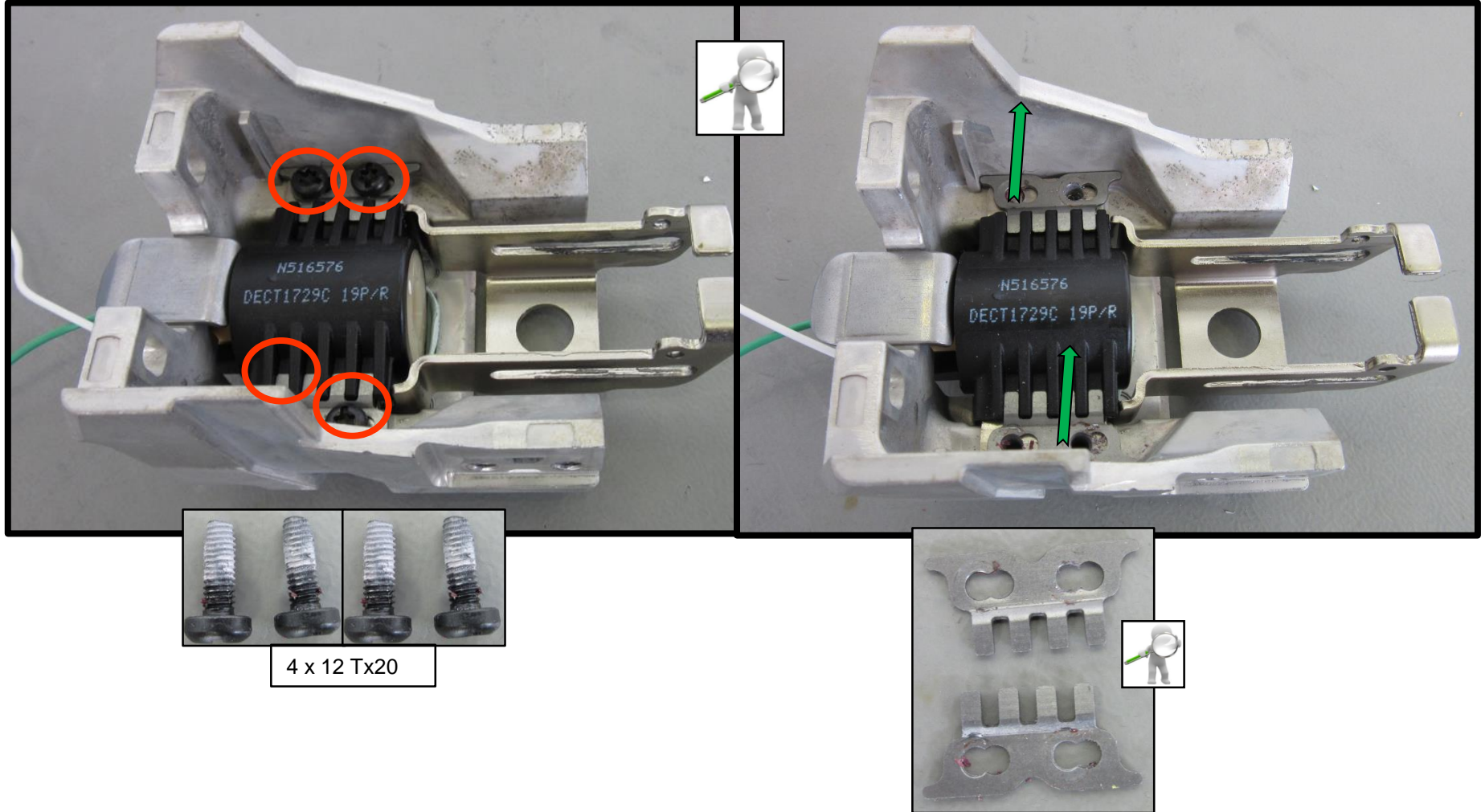

Disassembling procedure

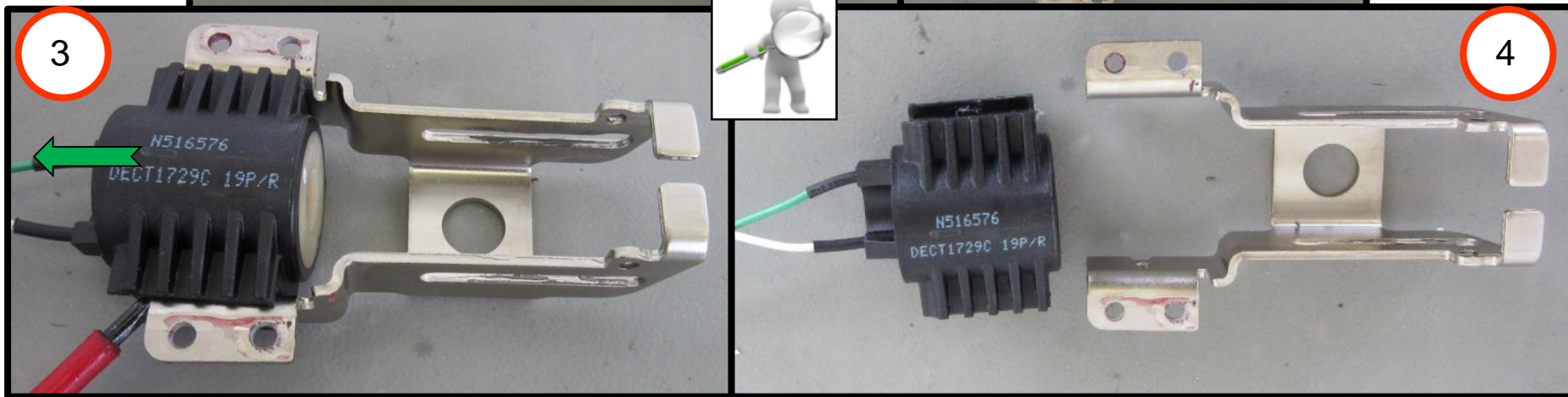
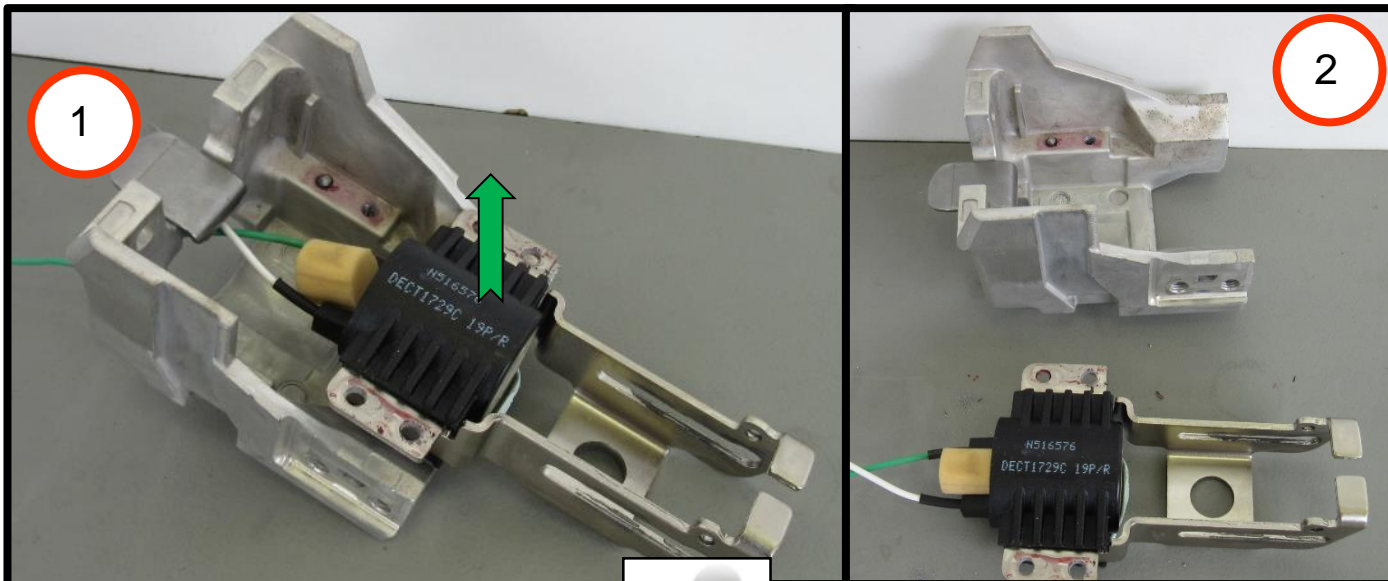

Disassembling procedure

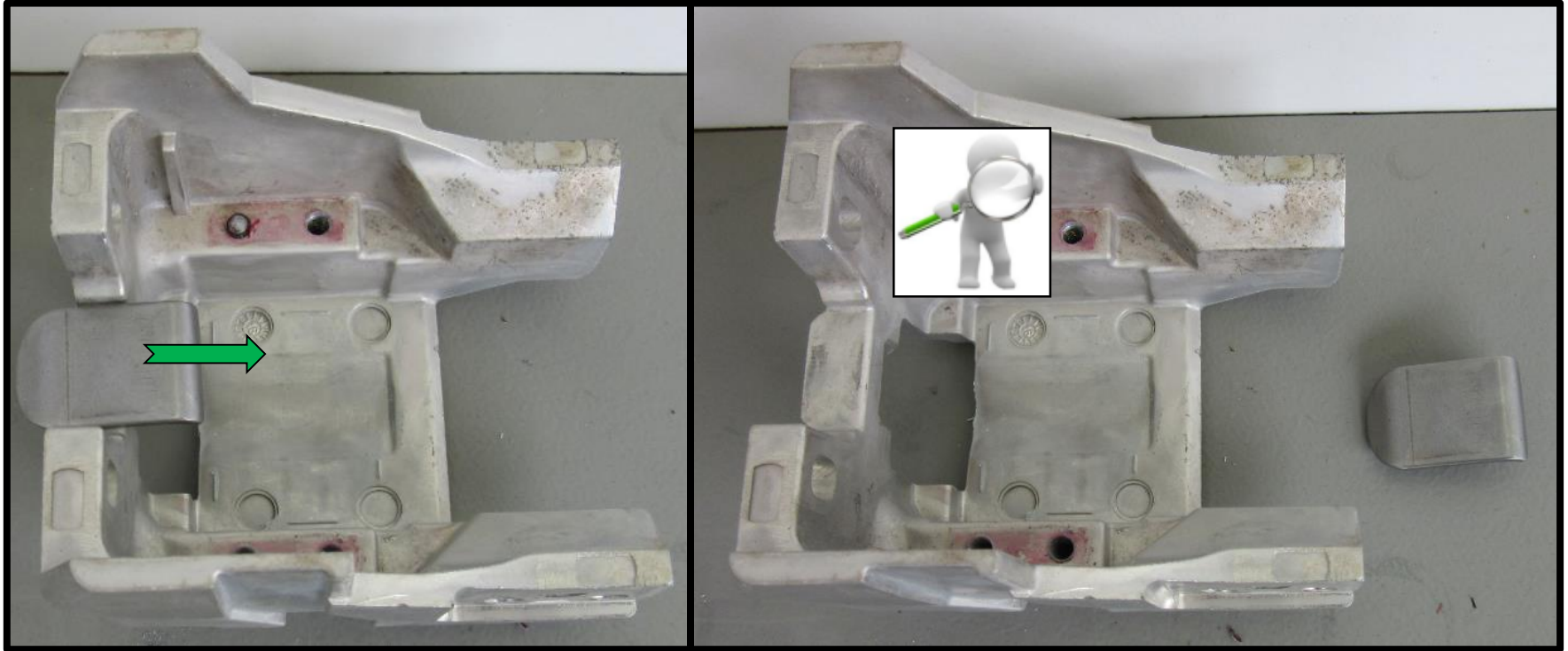

Disassembling procedure

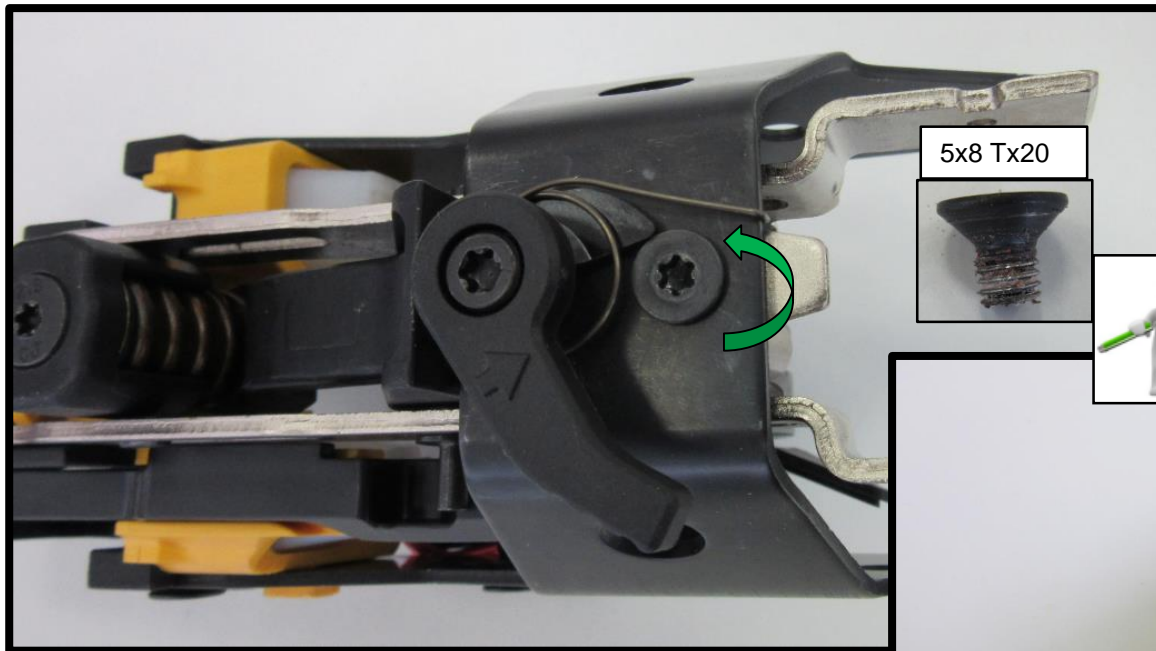

5x8 Tx20

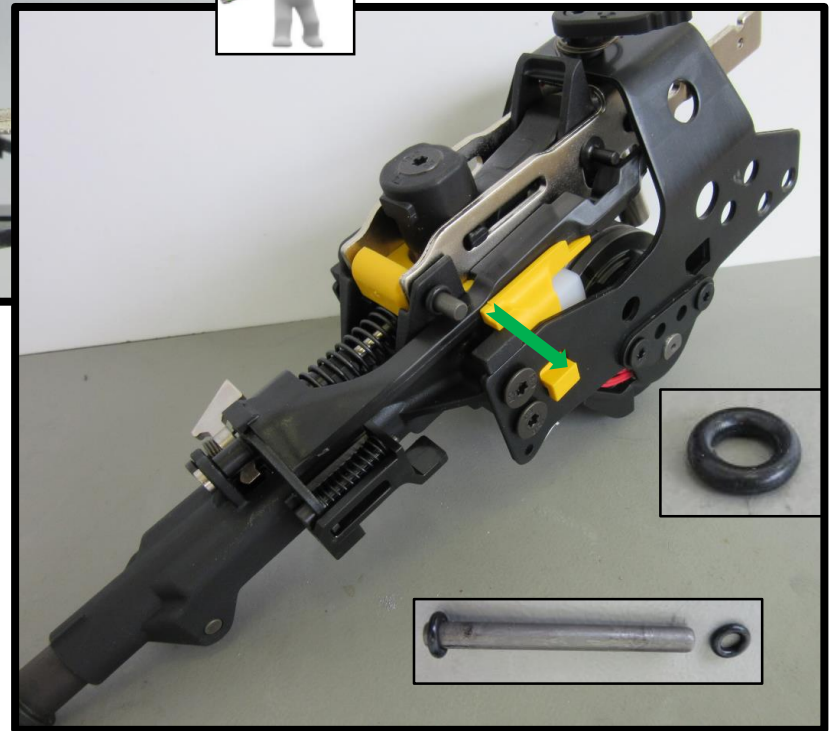

Disassembling procedure

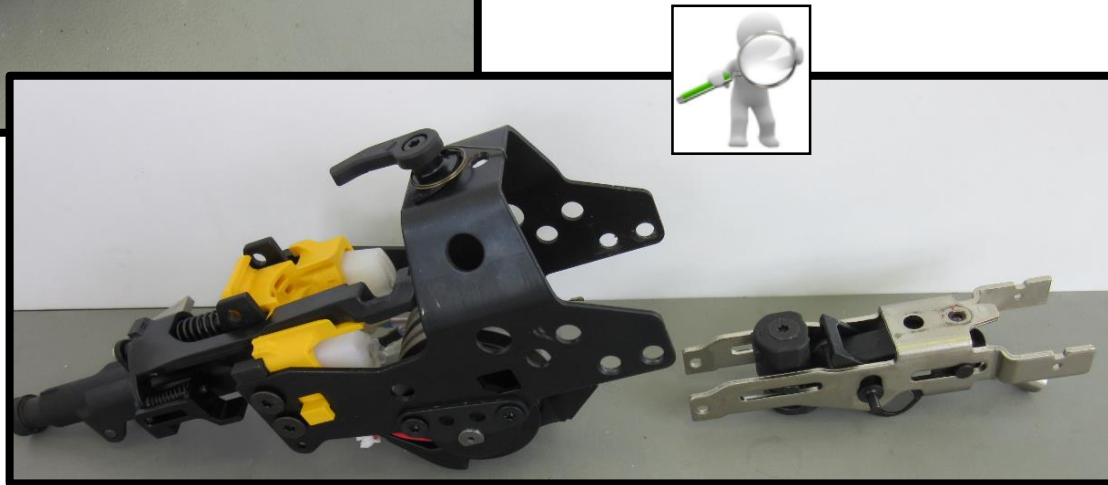
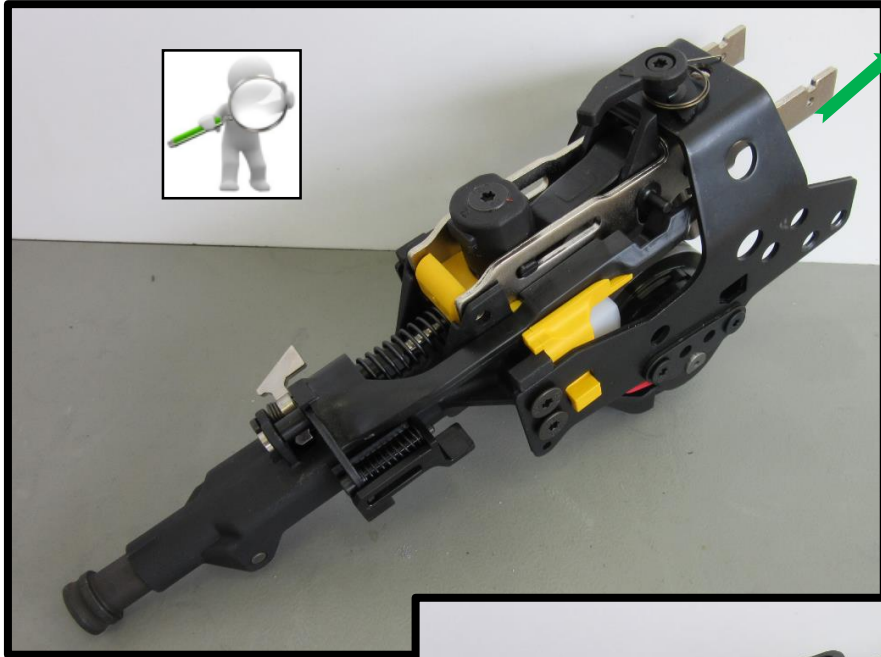

Disassembling procedure

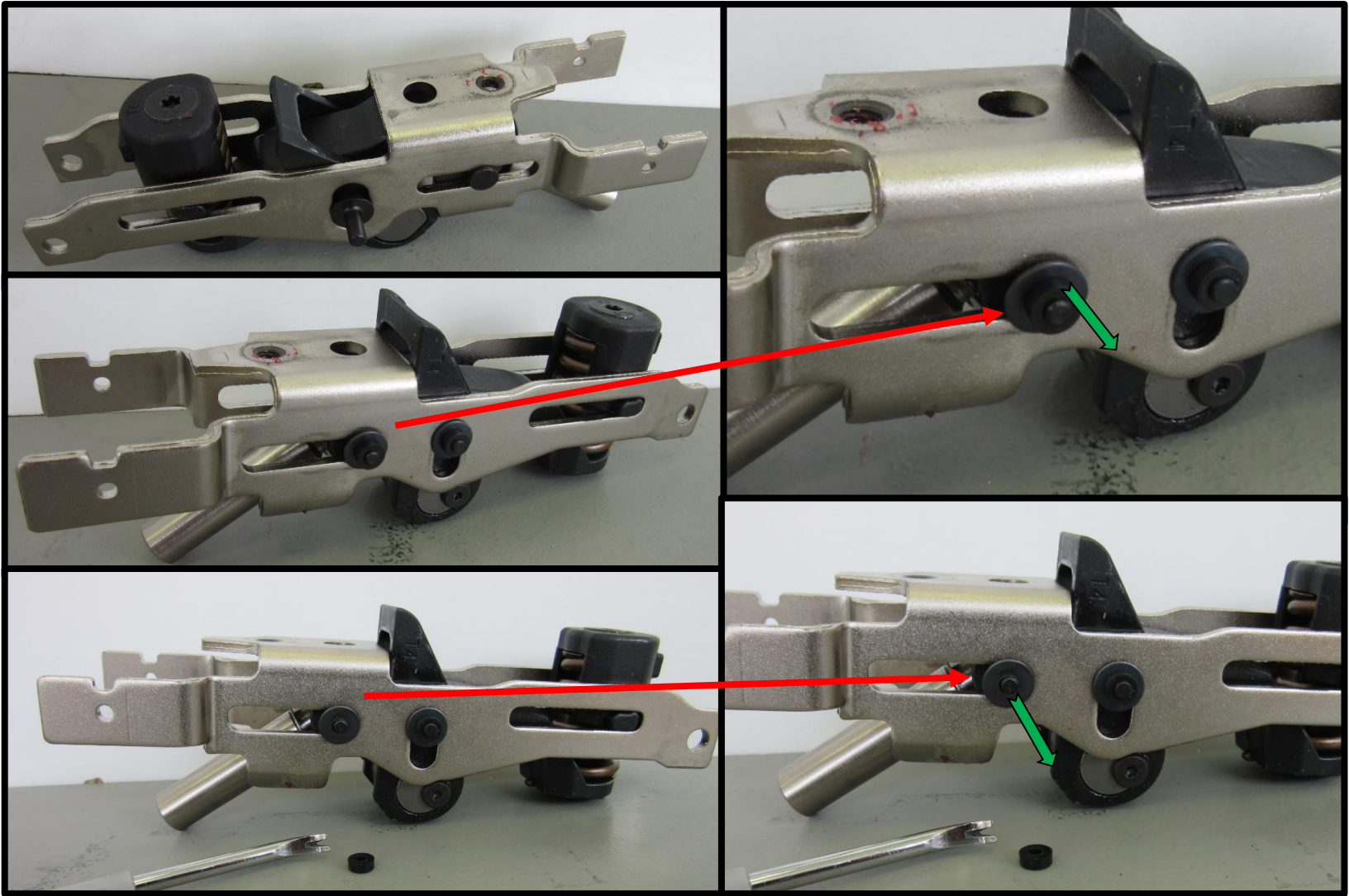

Disassembling procedure

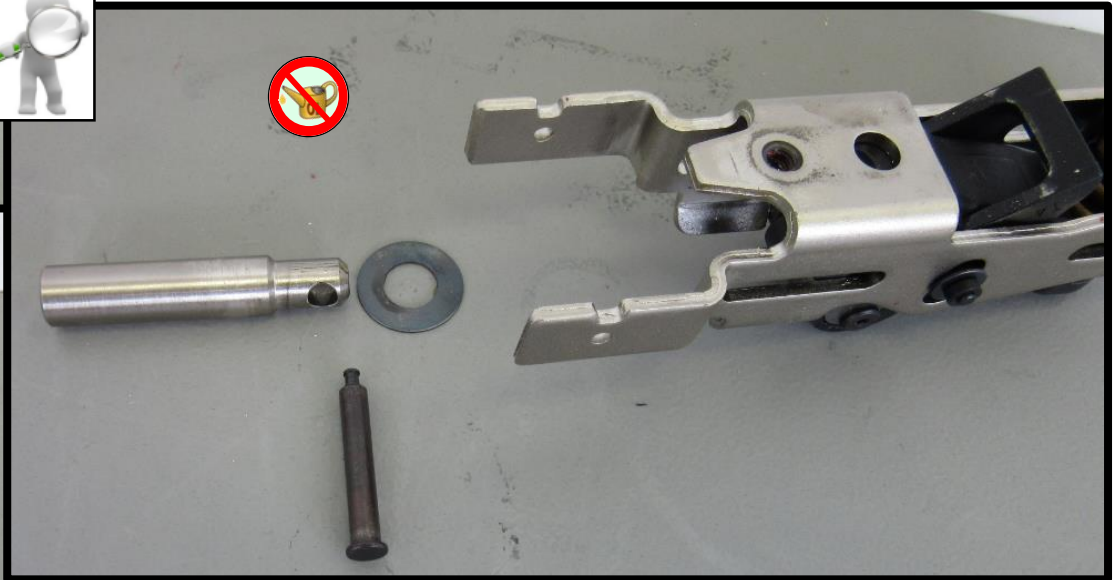
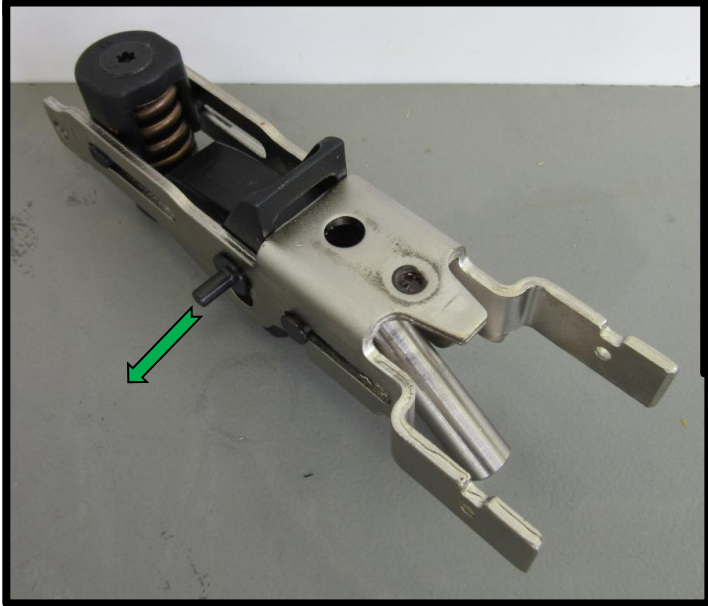
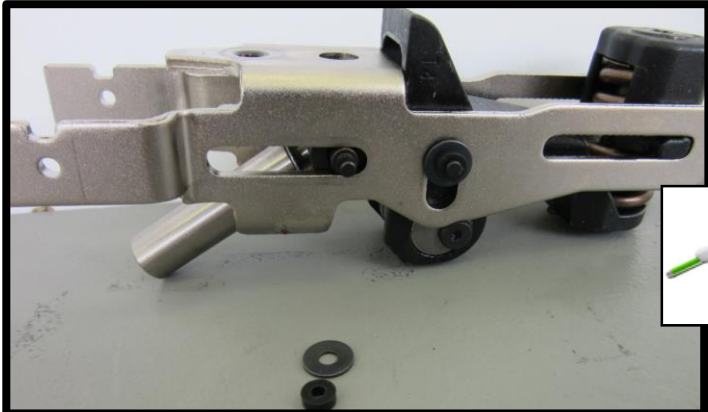

Disassembling procedure

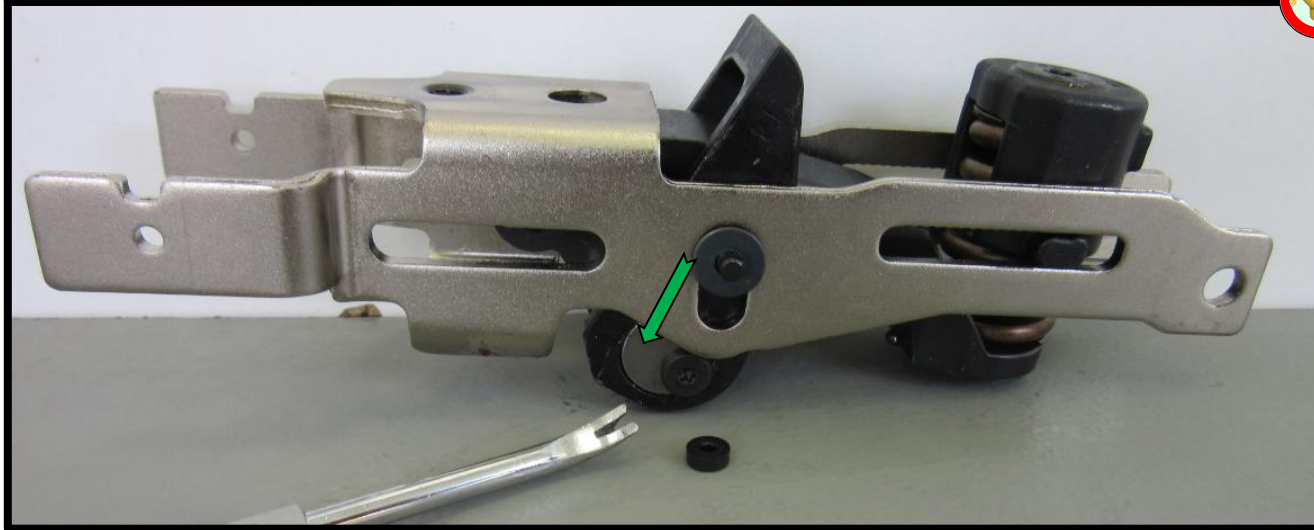
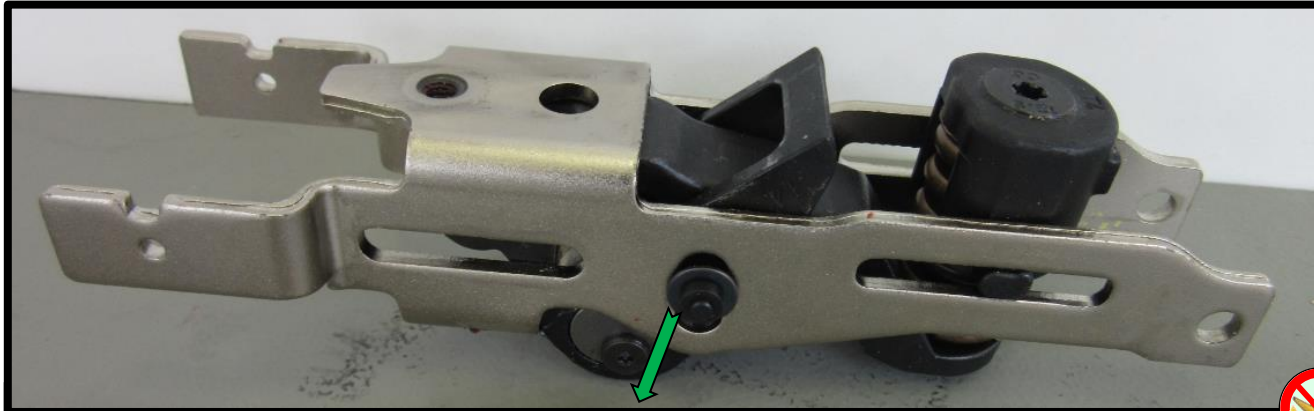

Disassembling procedure

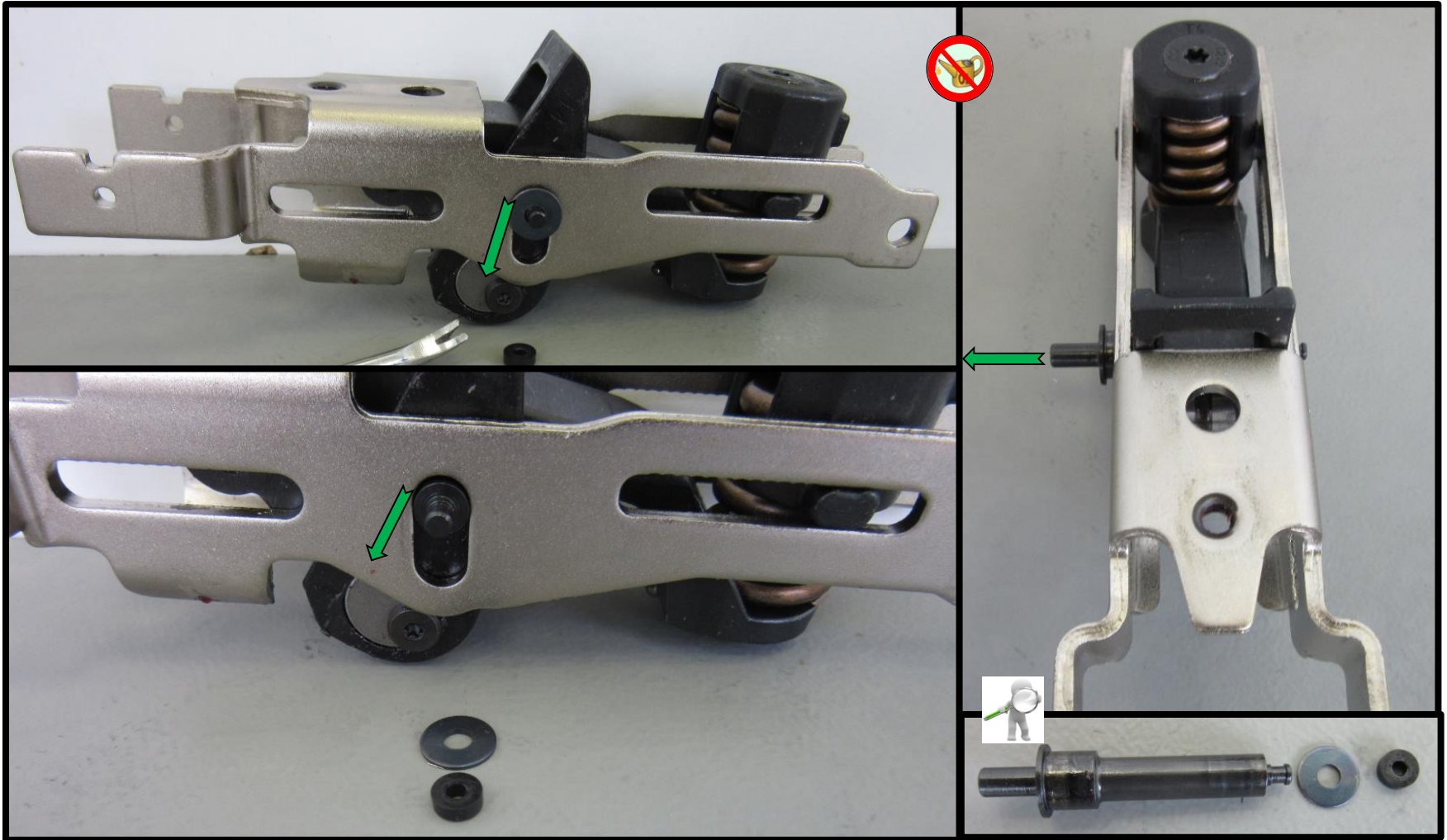

Disassembling procedure

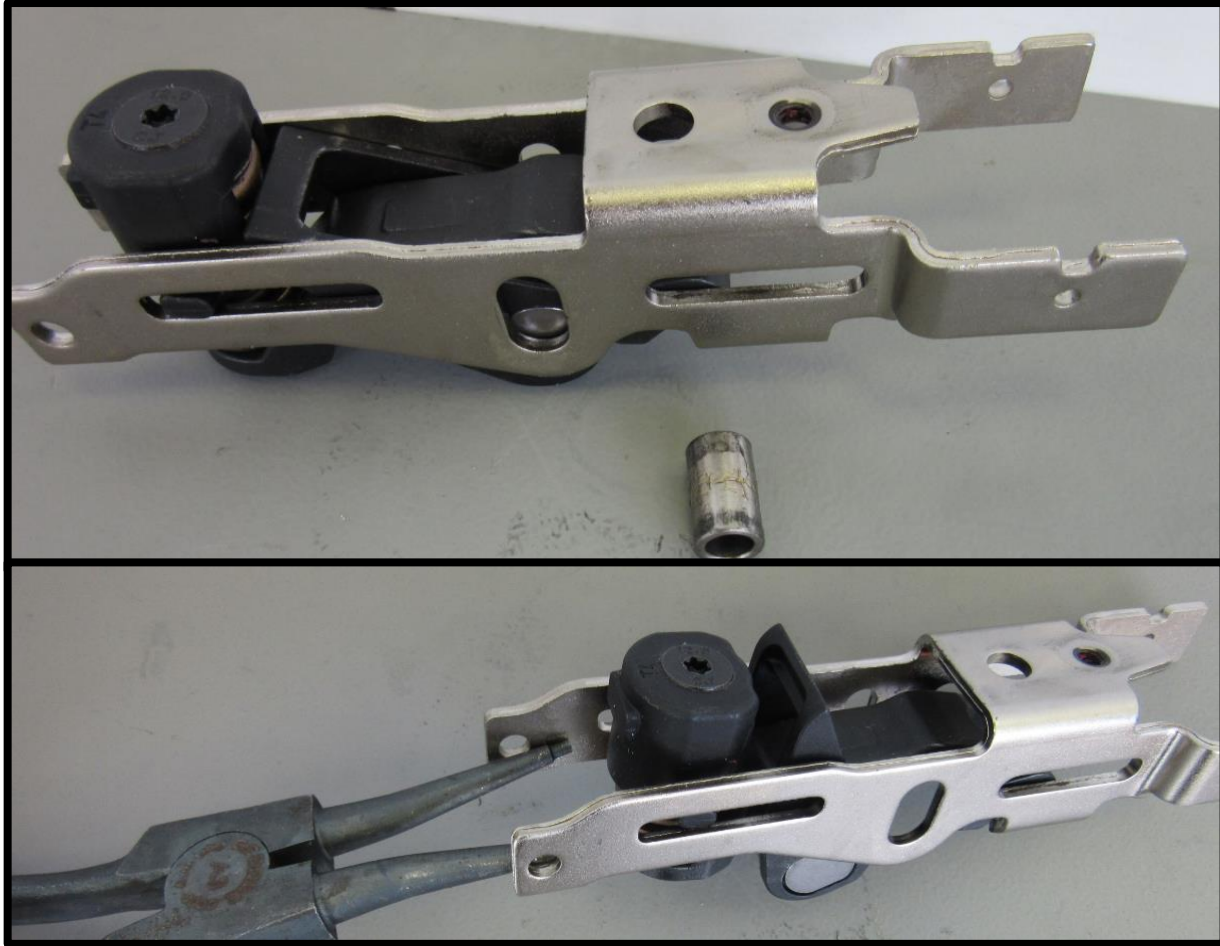

Disassembling procedure



Disassembling procedure



Disassembling procedure

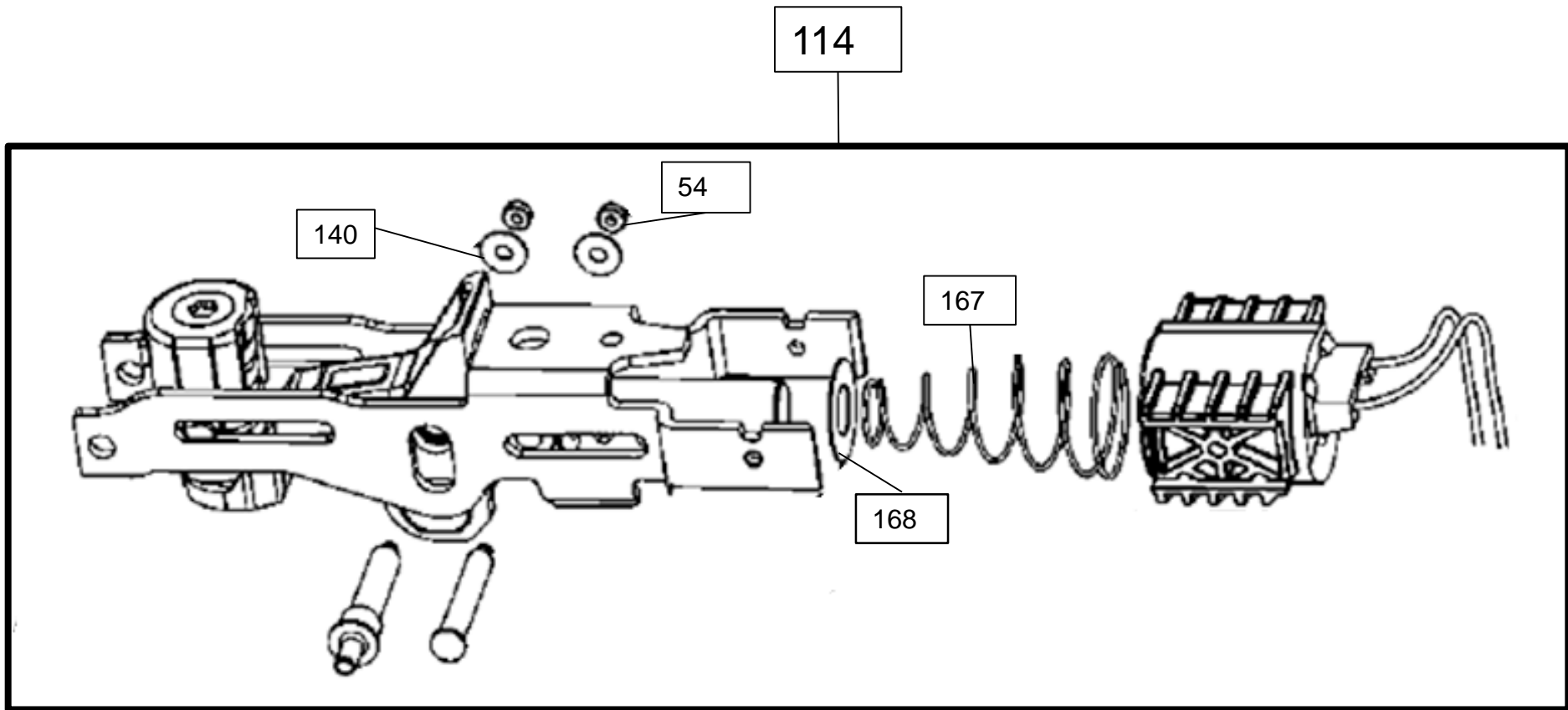

Disassembling procedure

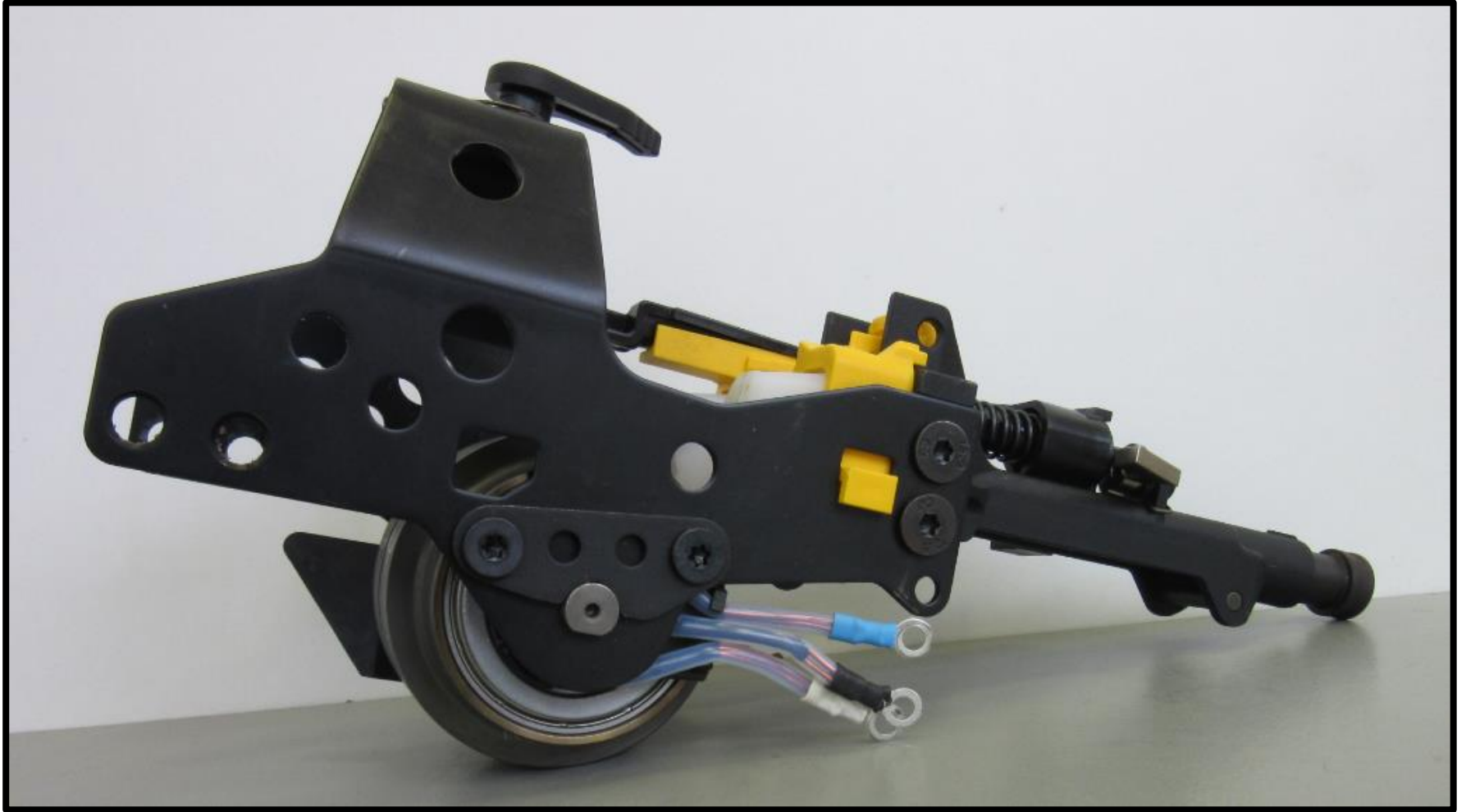

Disassembling procedure

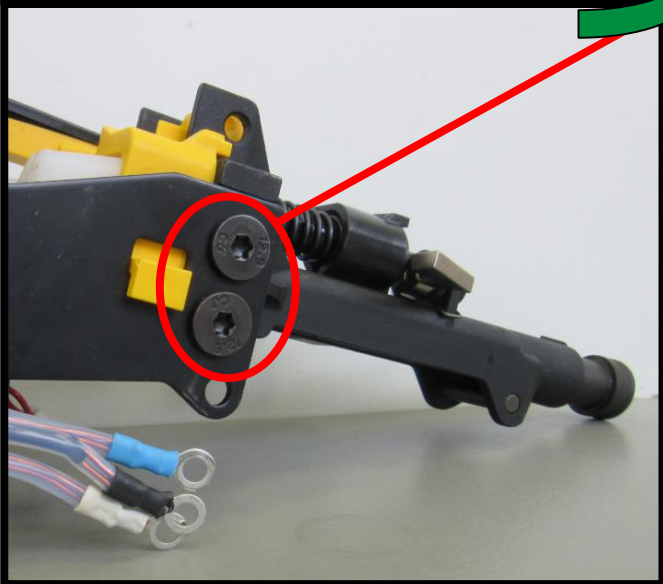
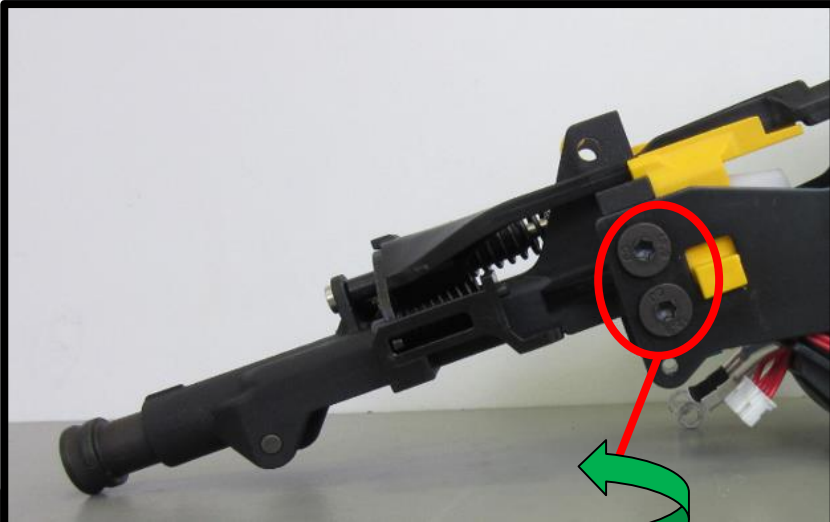

Disassembling procedure

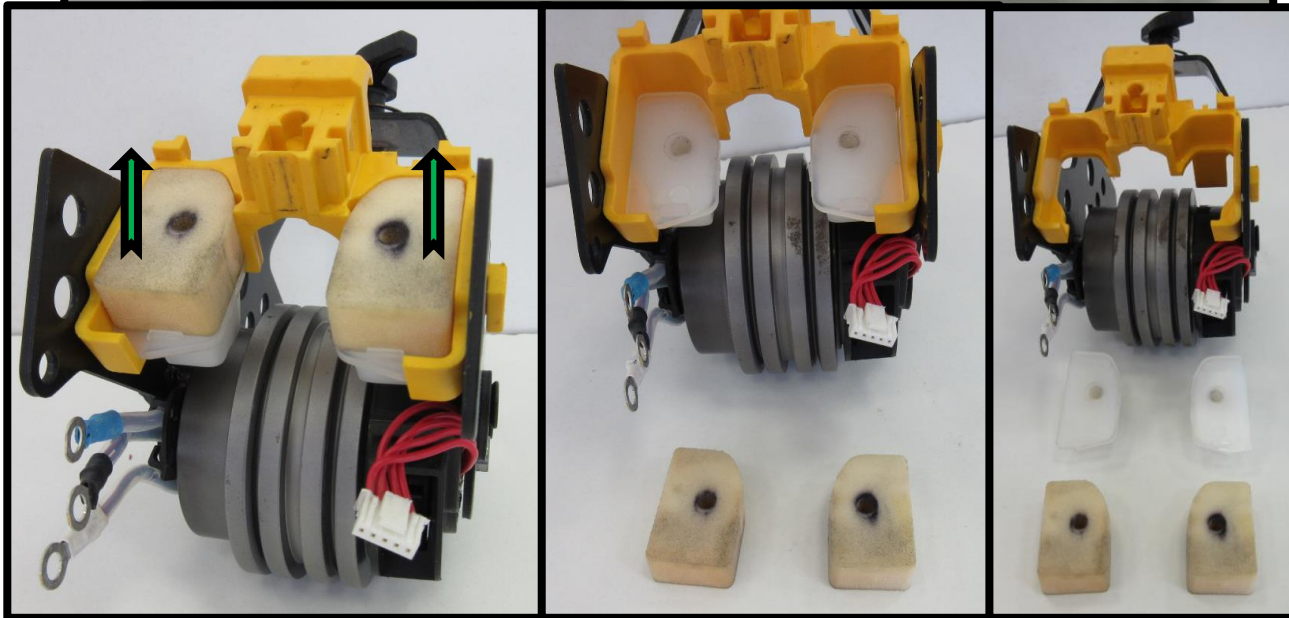
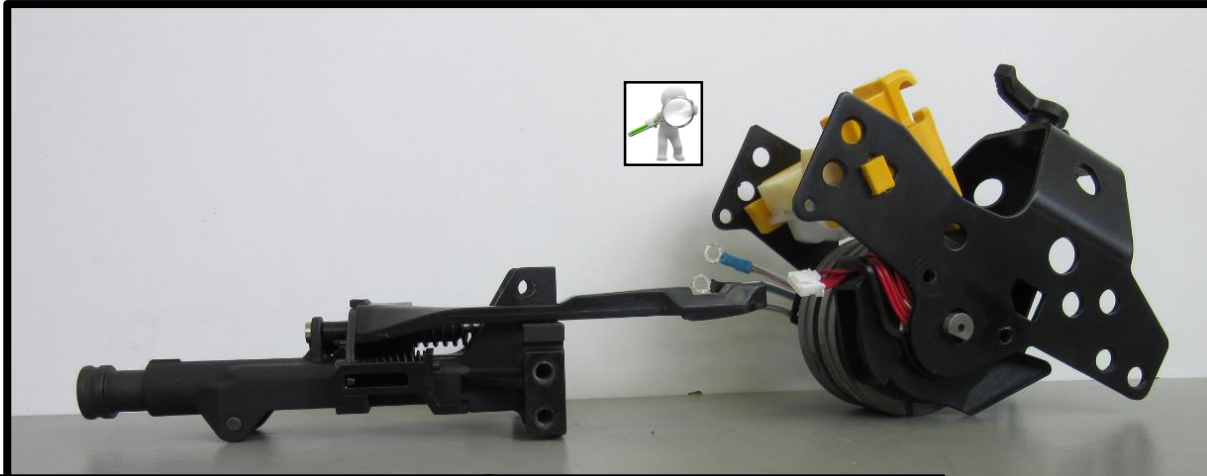

Disassembling procedure

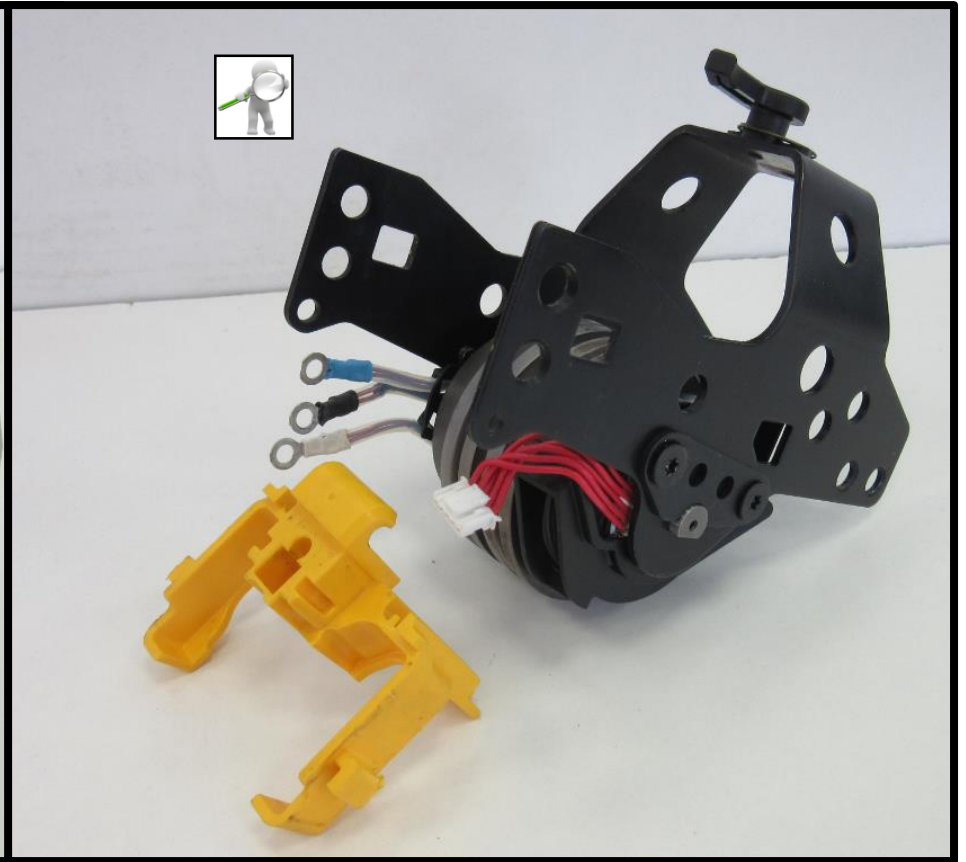
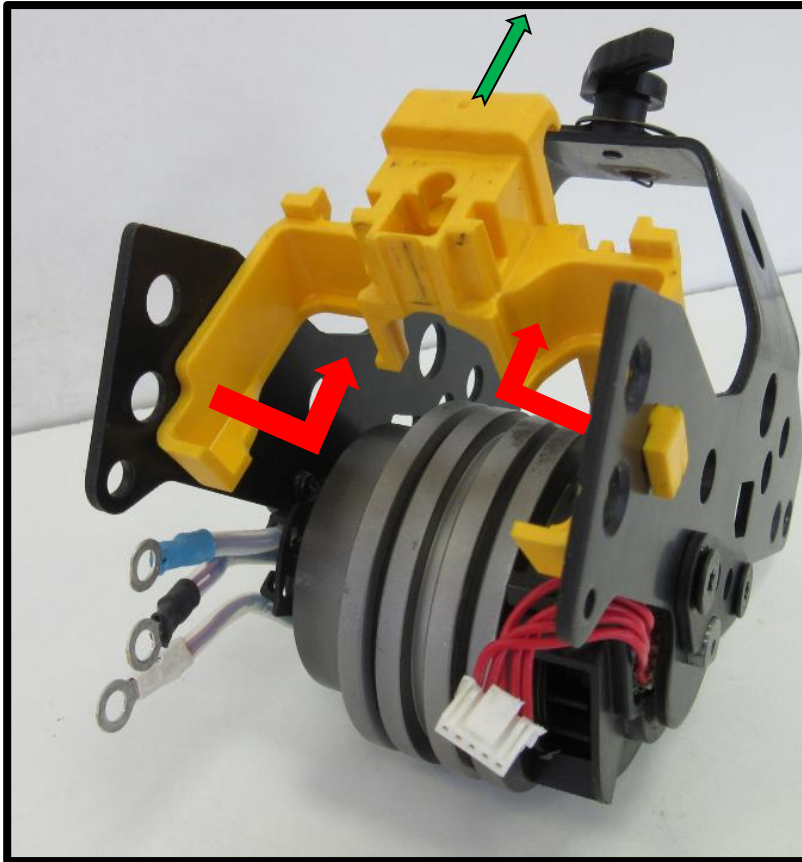

Disassembling procedure

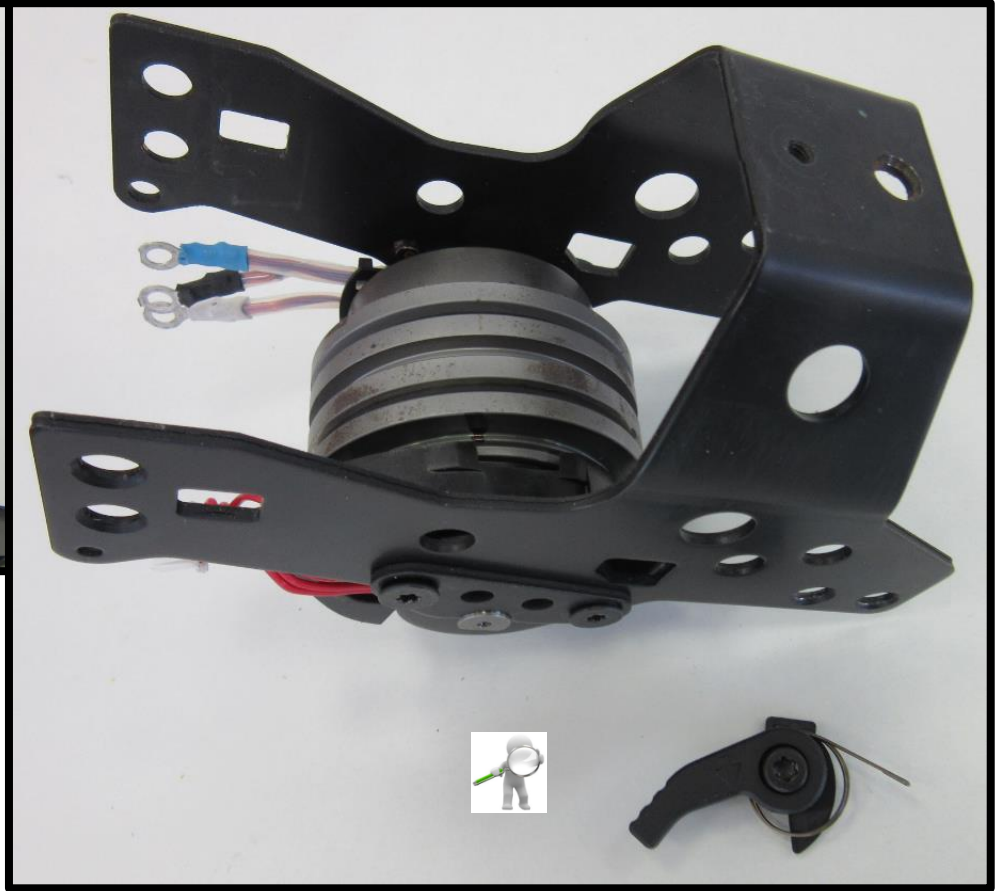
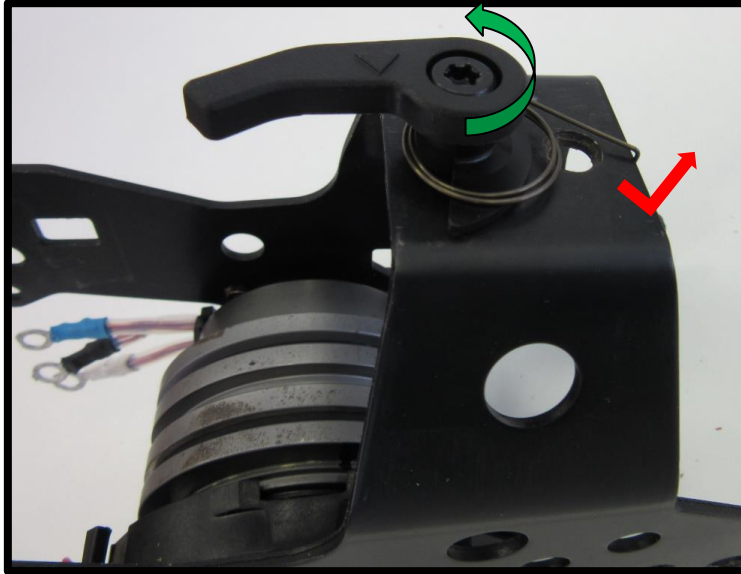

Disassembling procedure

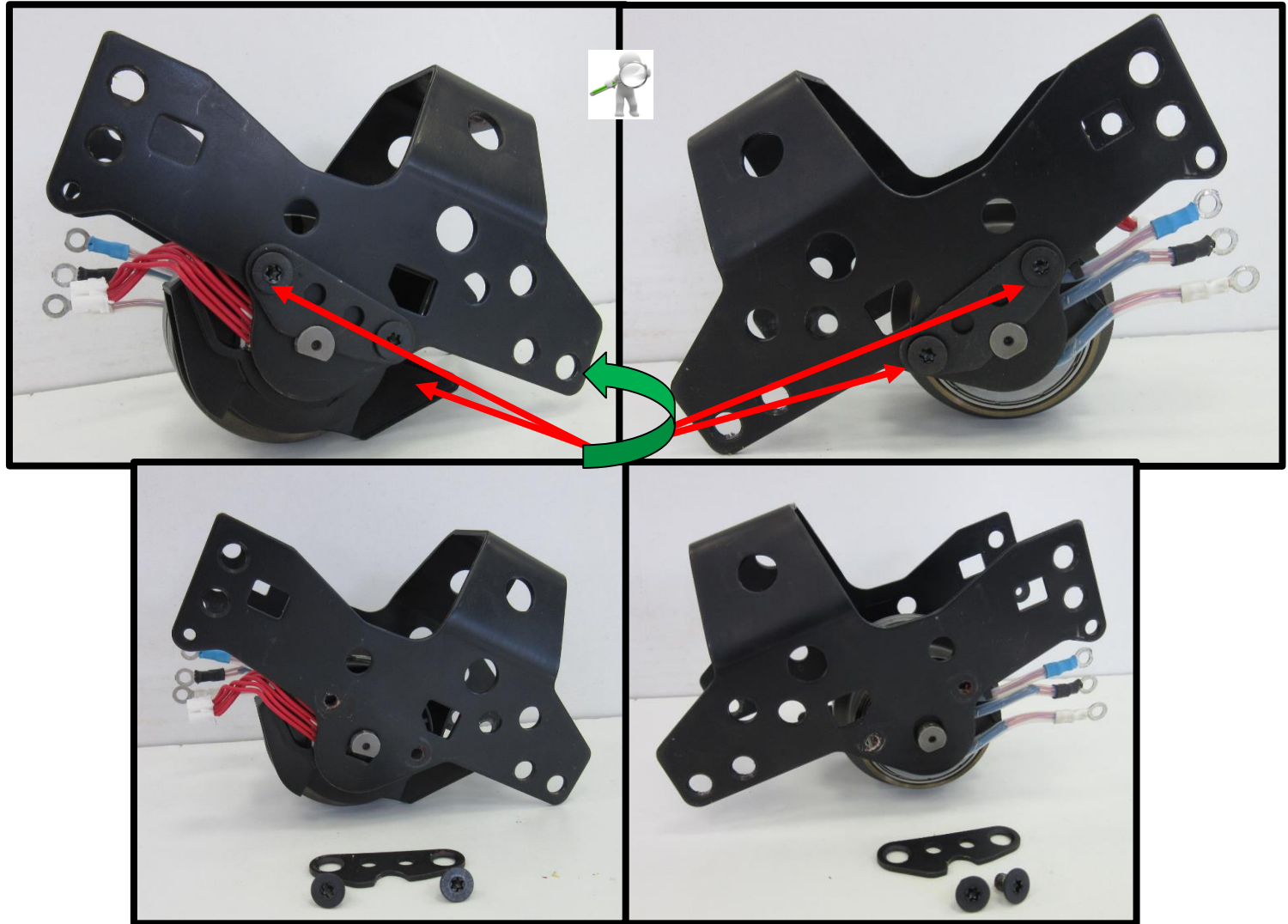

Disassembling procedure

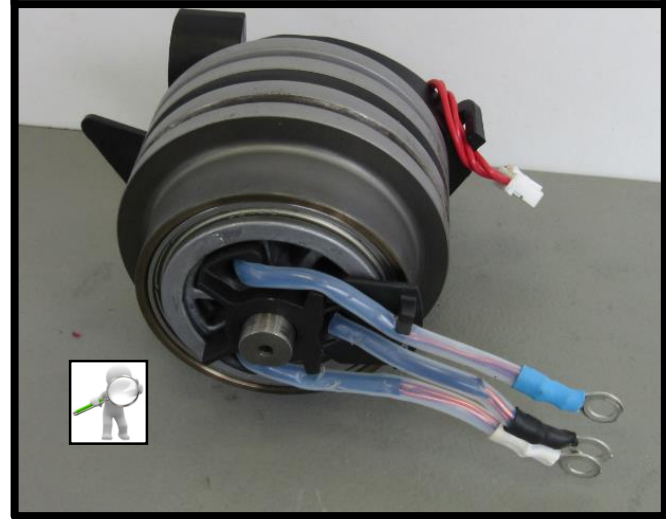
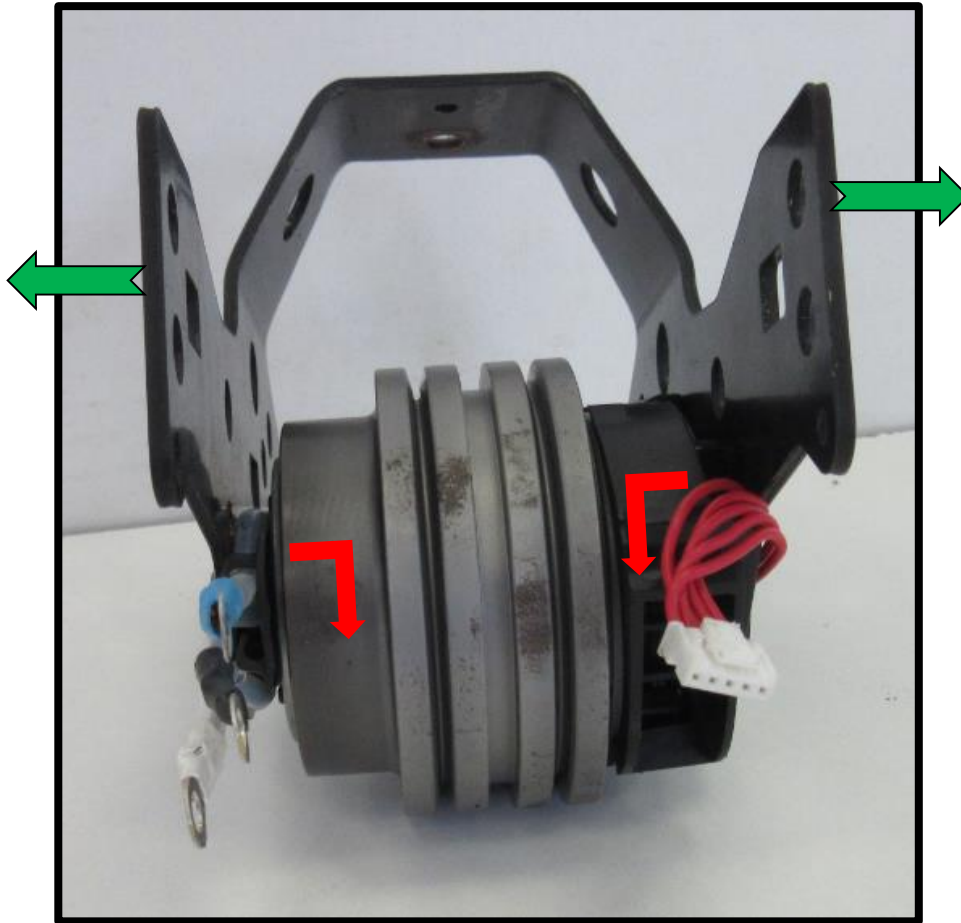

Disassembling procedure

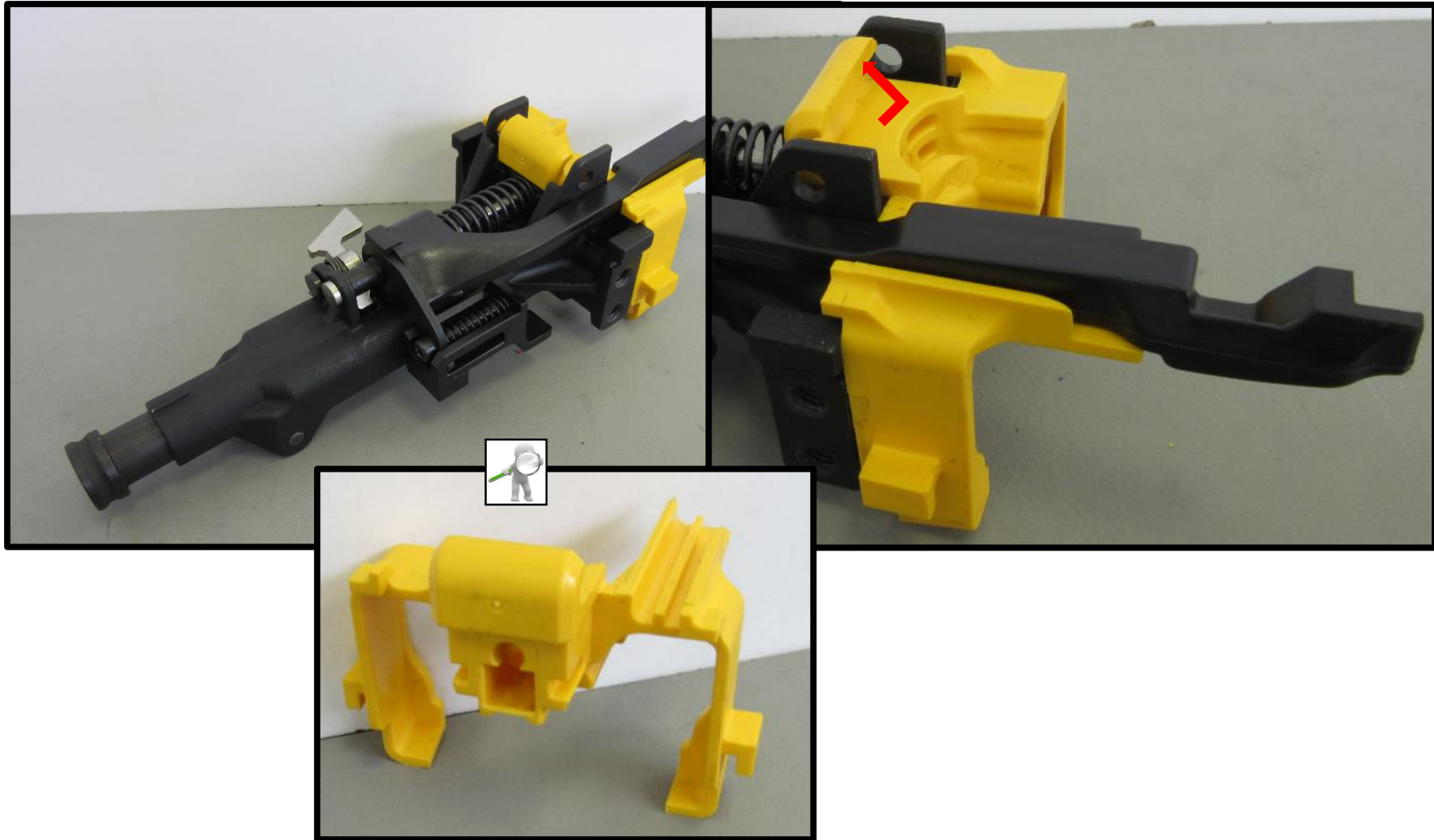

Disassembling procedure

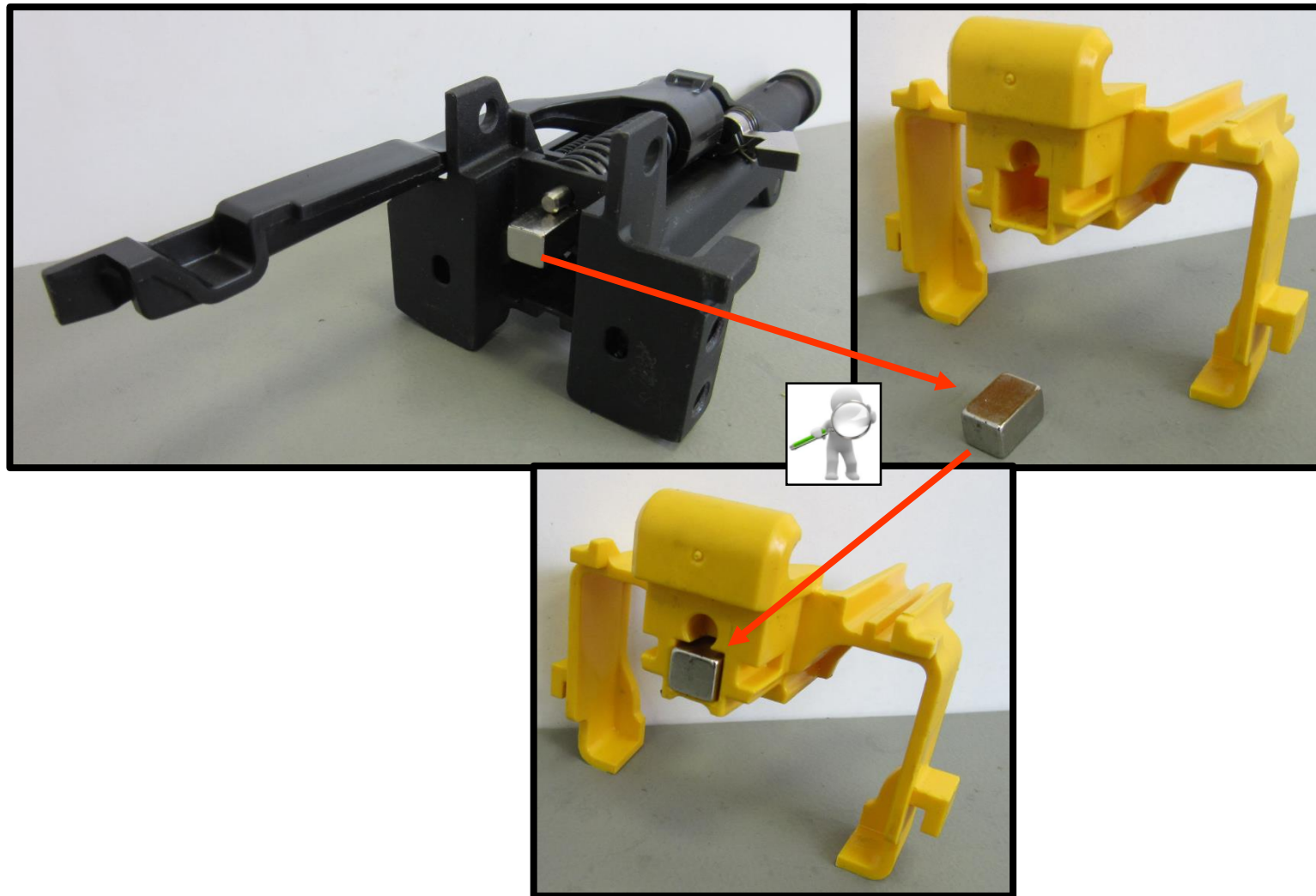

Disassembling procedure

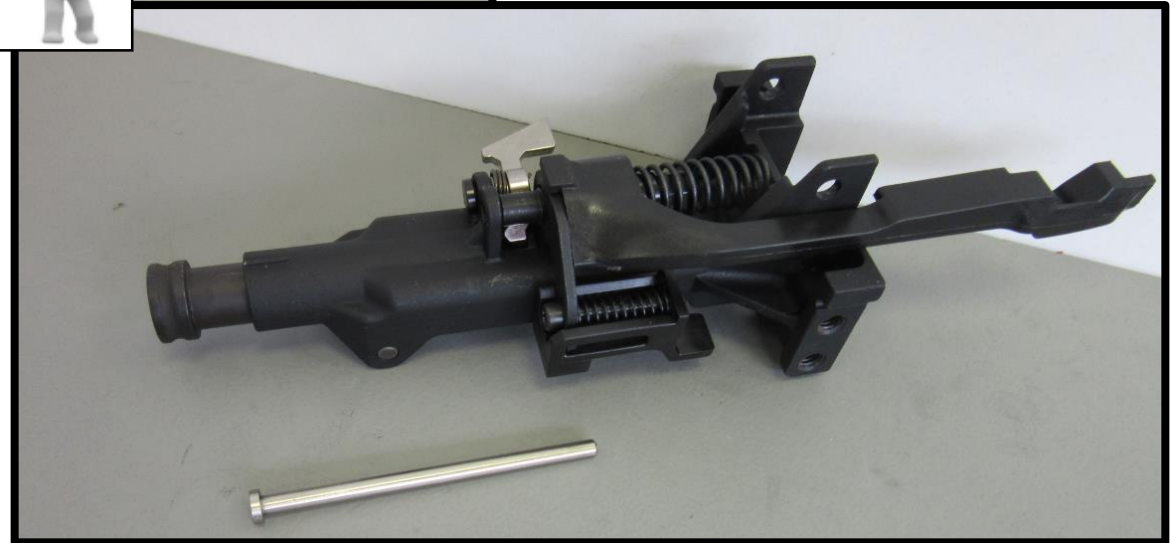
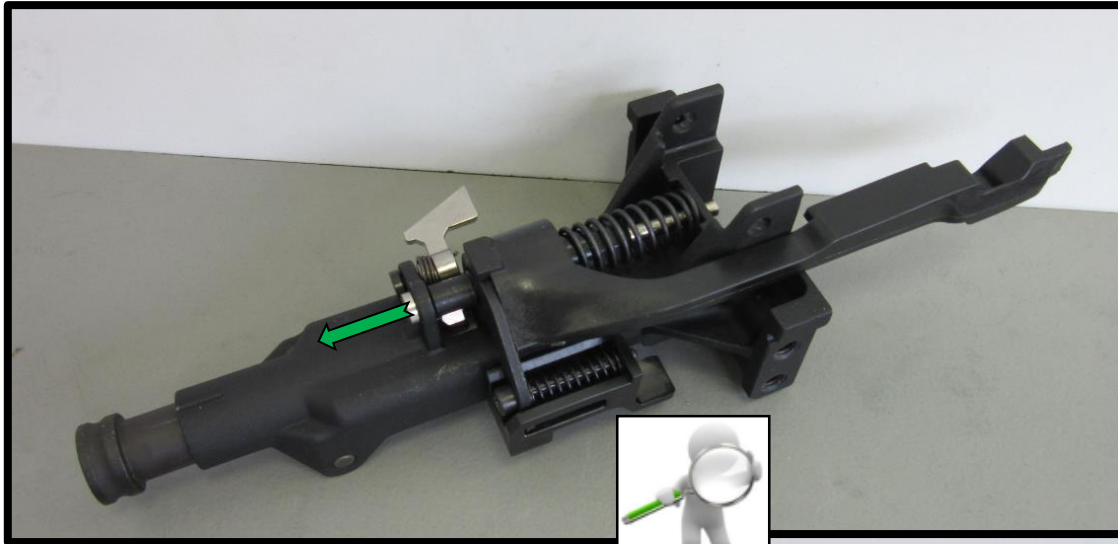

Disassembling procedure

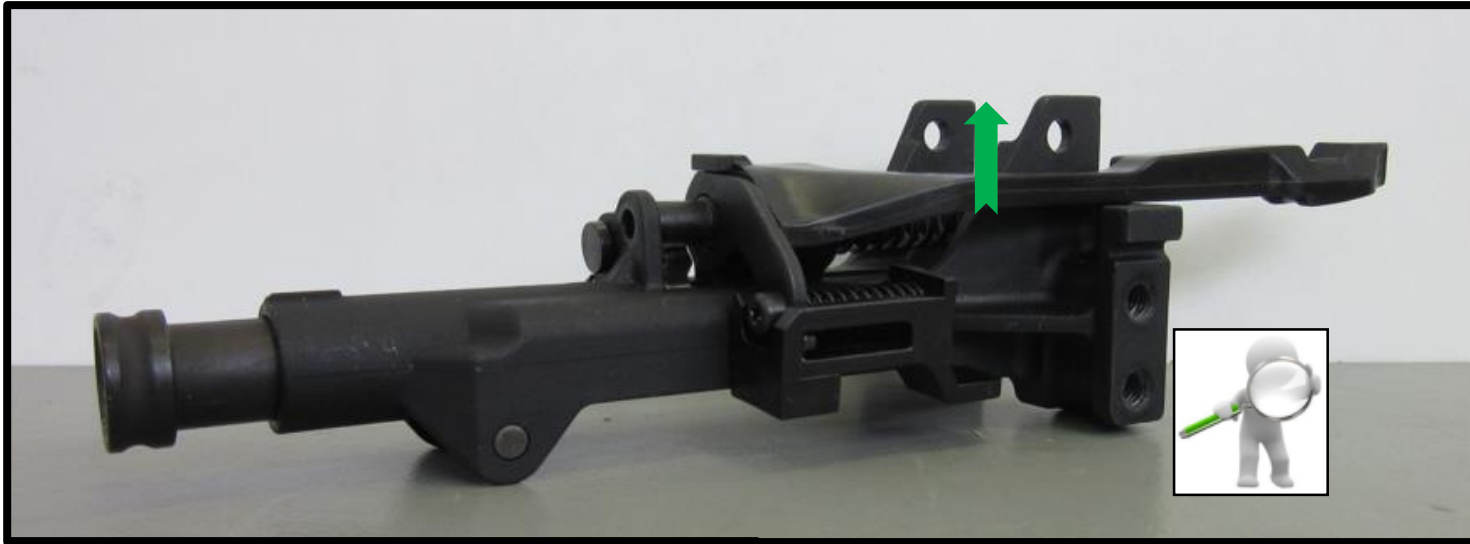

Disassembling procedure

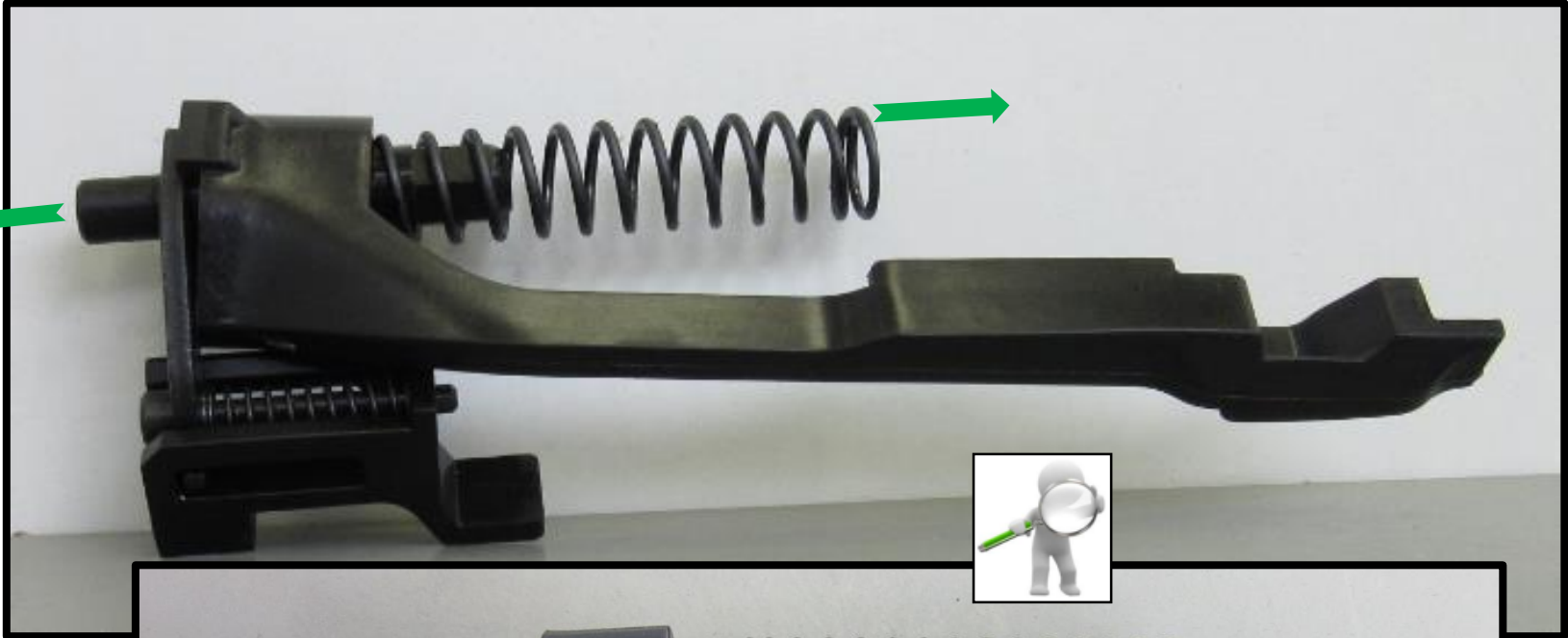

Disassembling procedure

27

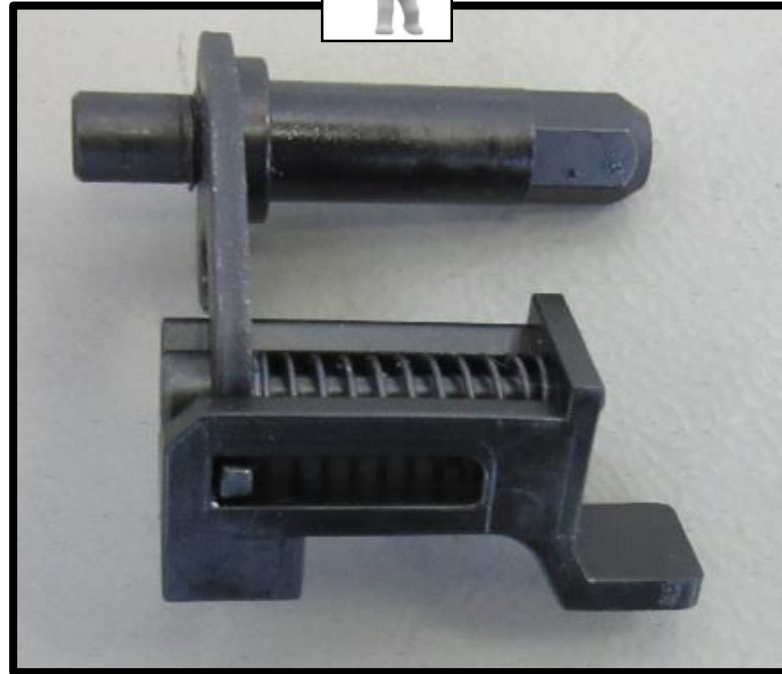
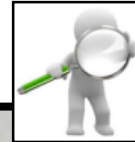
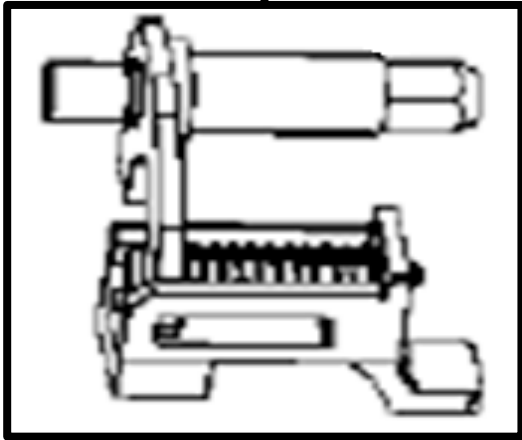

Disassembling procedure

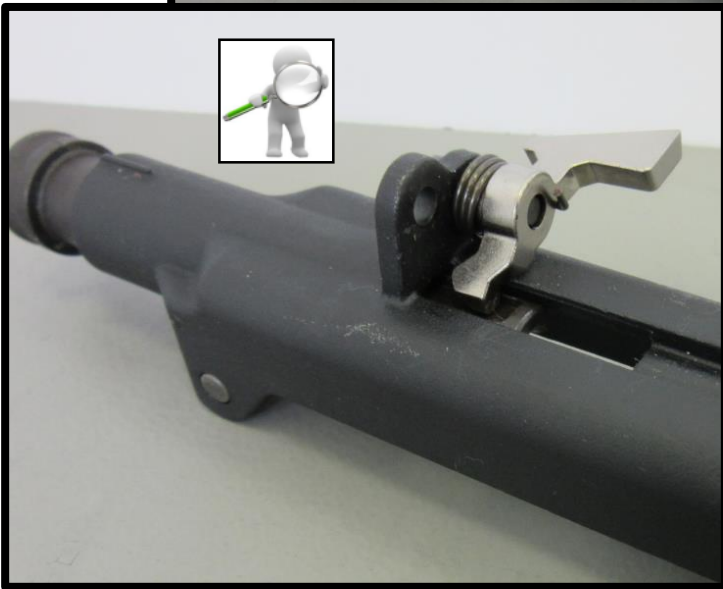
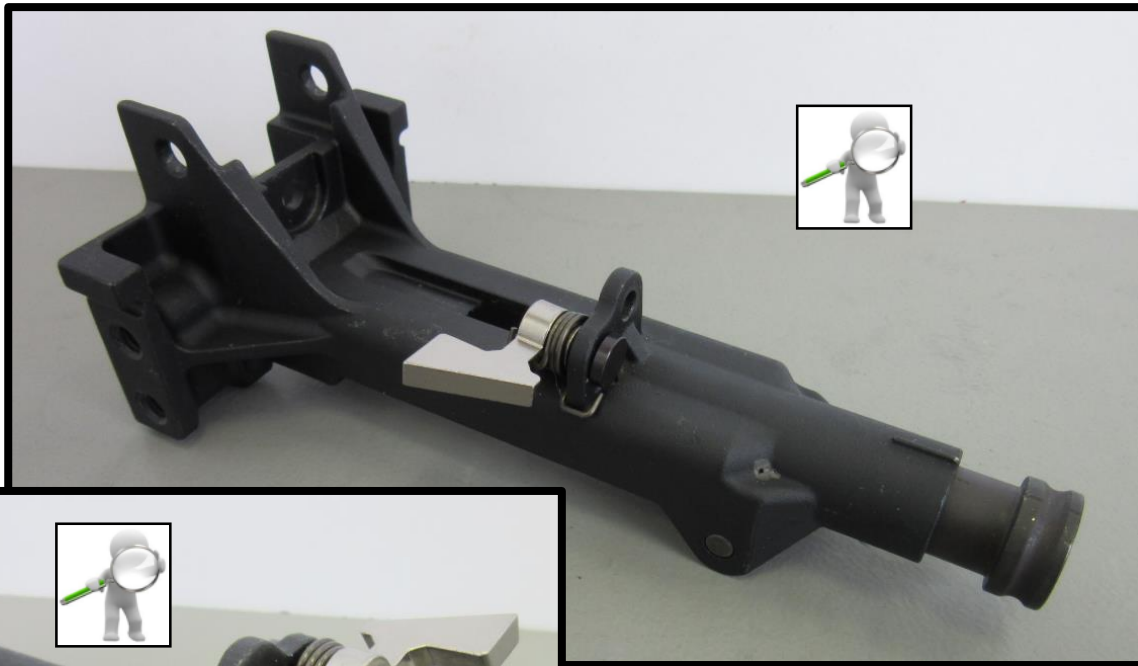

Assembling Hints

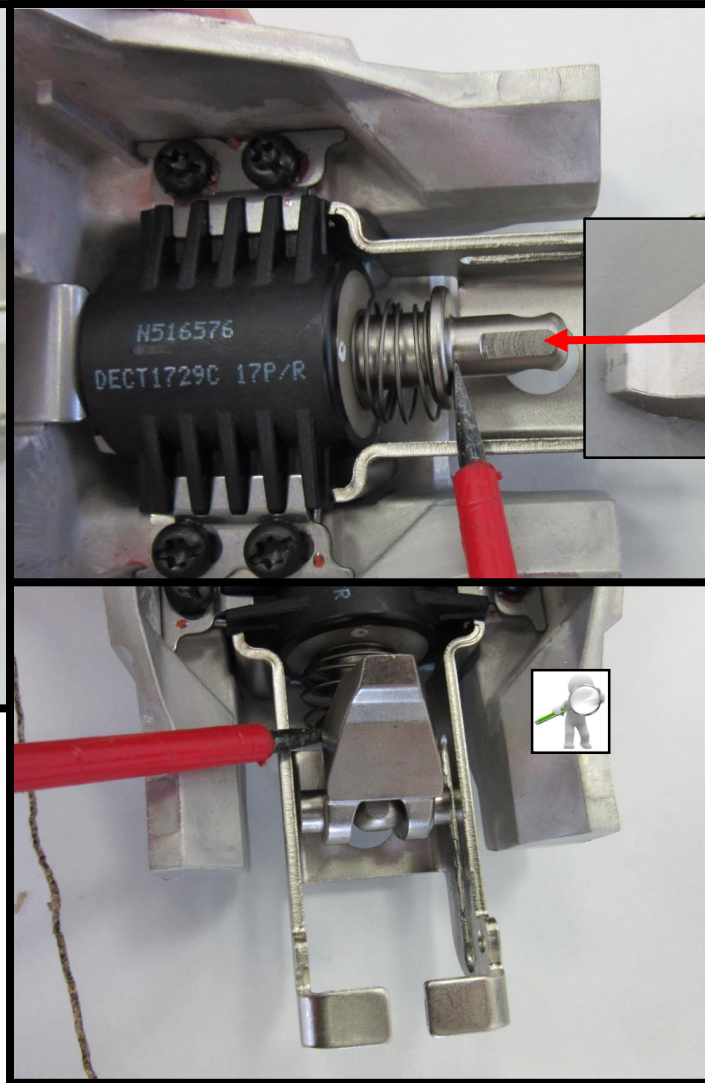
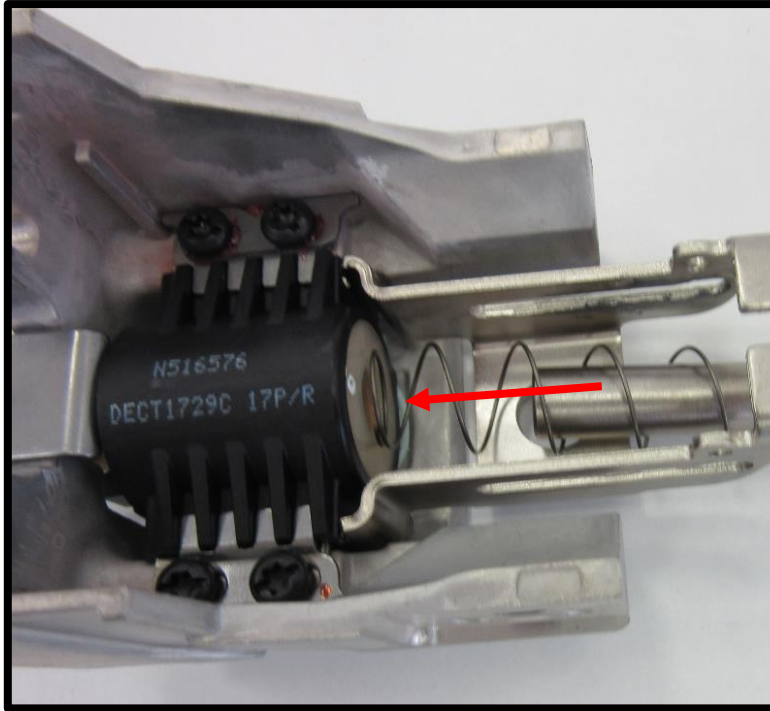

Assembling procedure

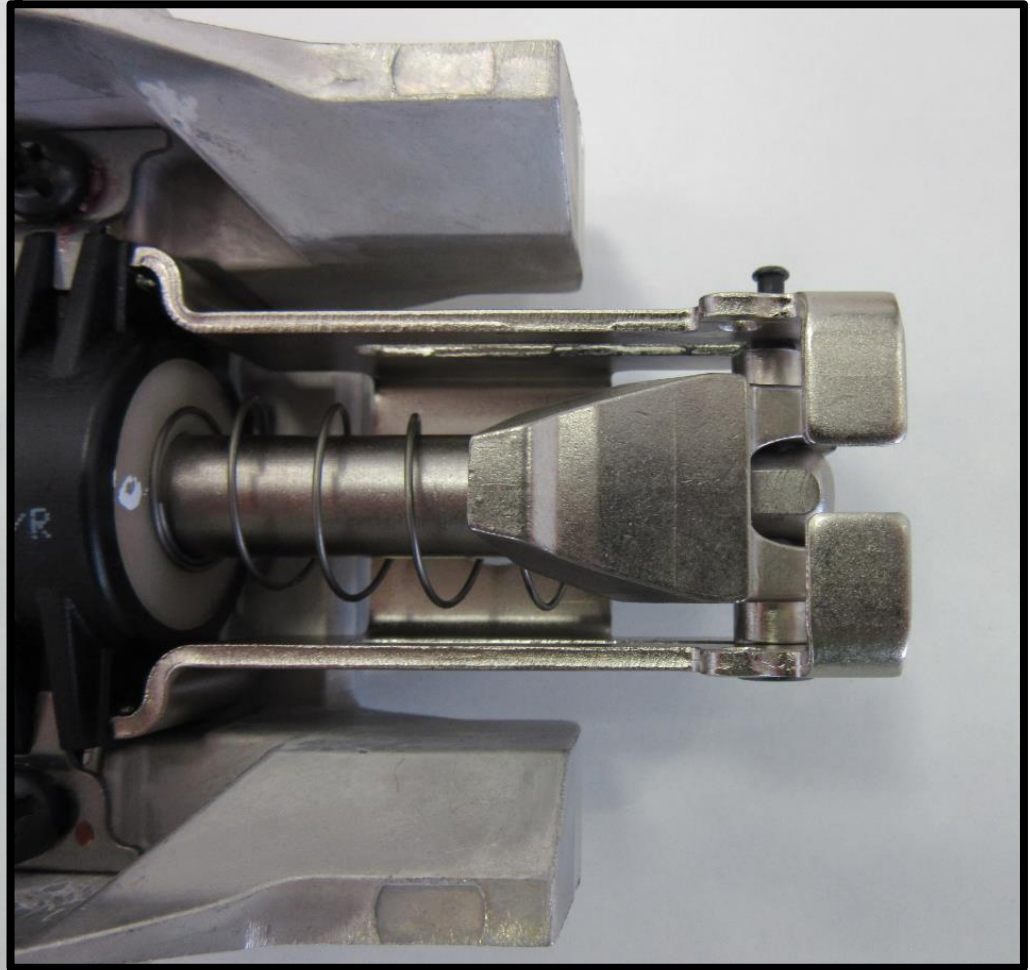
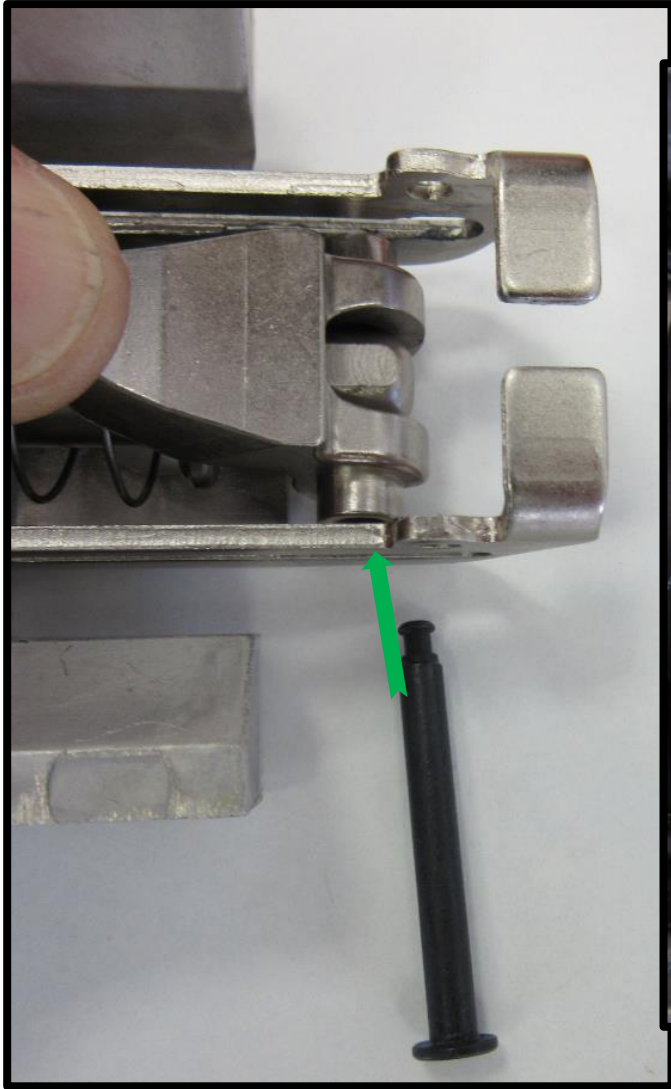

Assembling procedure

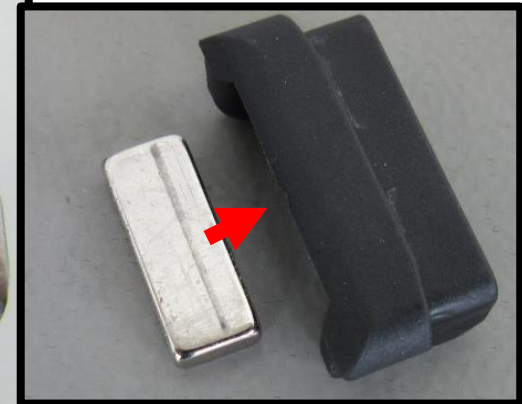
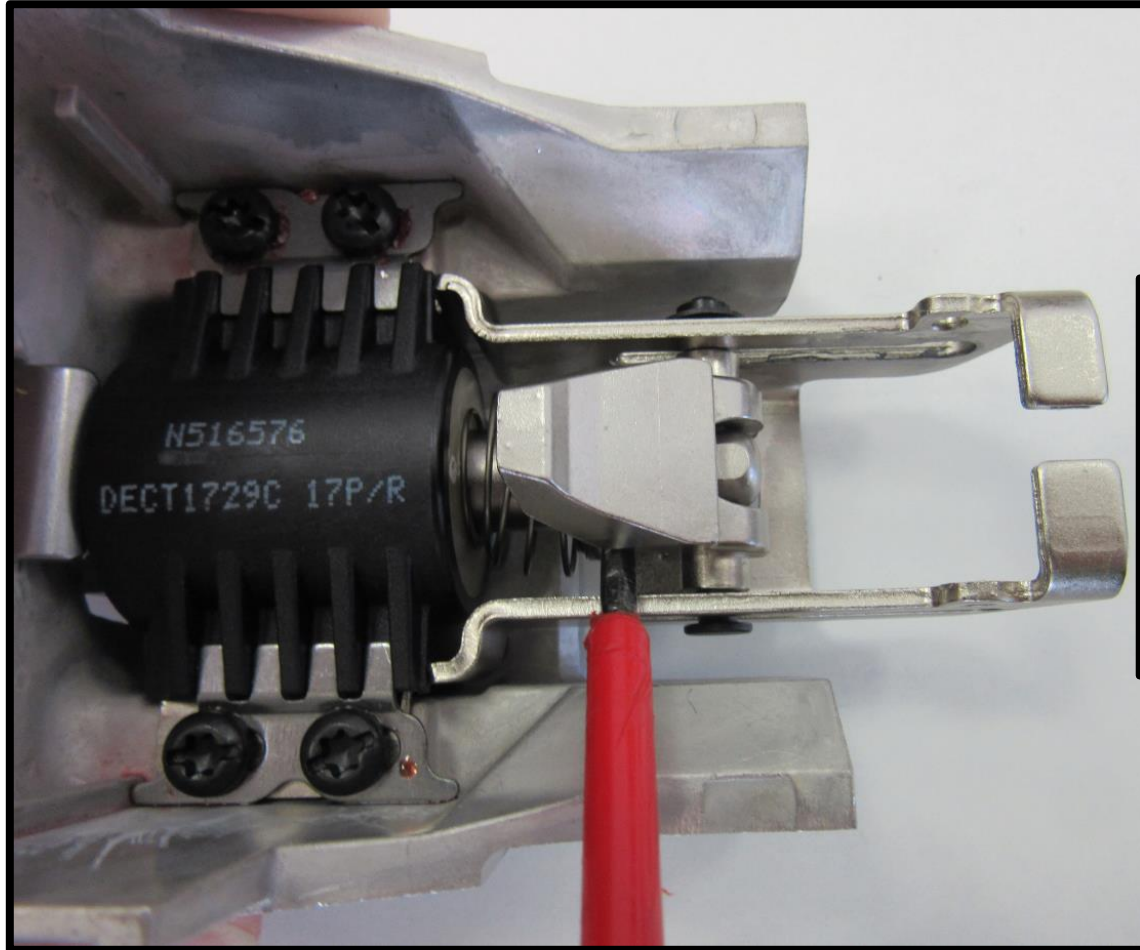

Assembling procedure

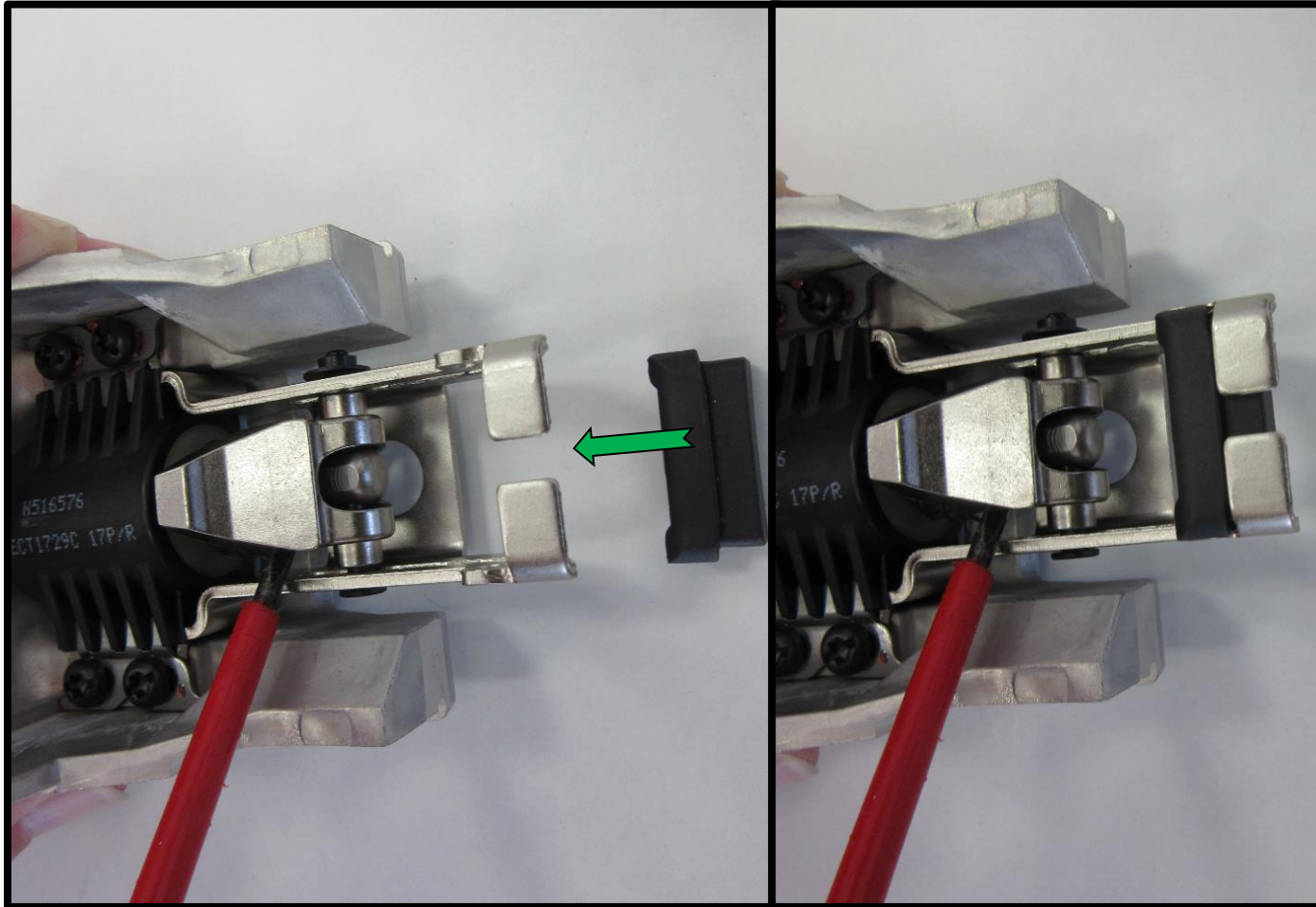

Assembling procedure

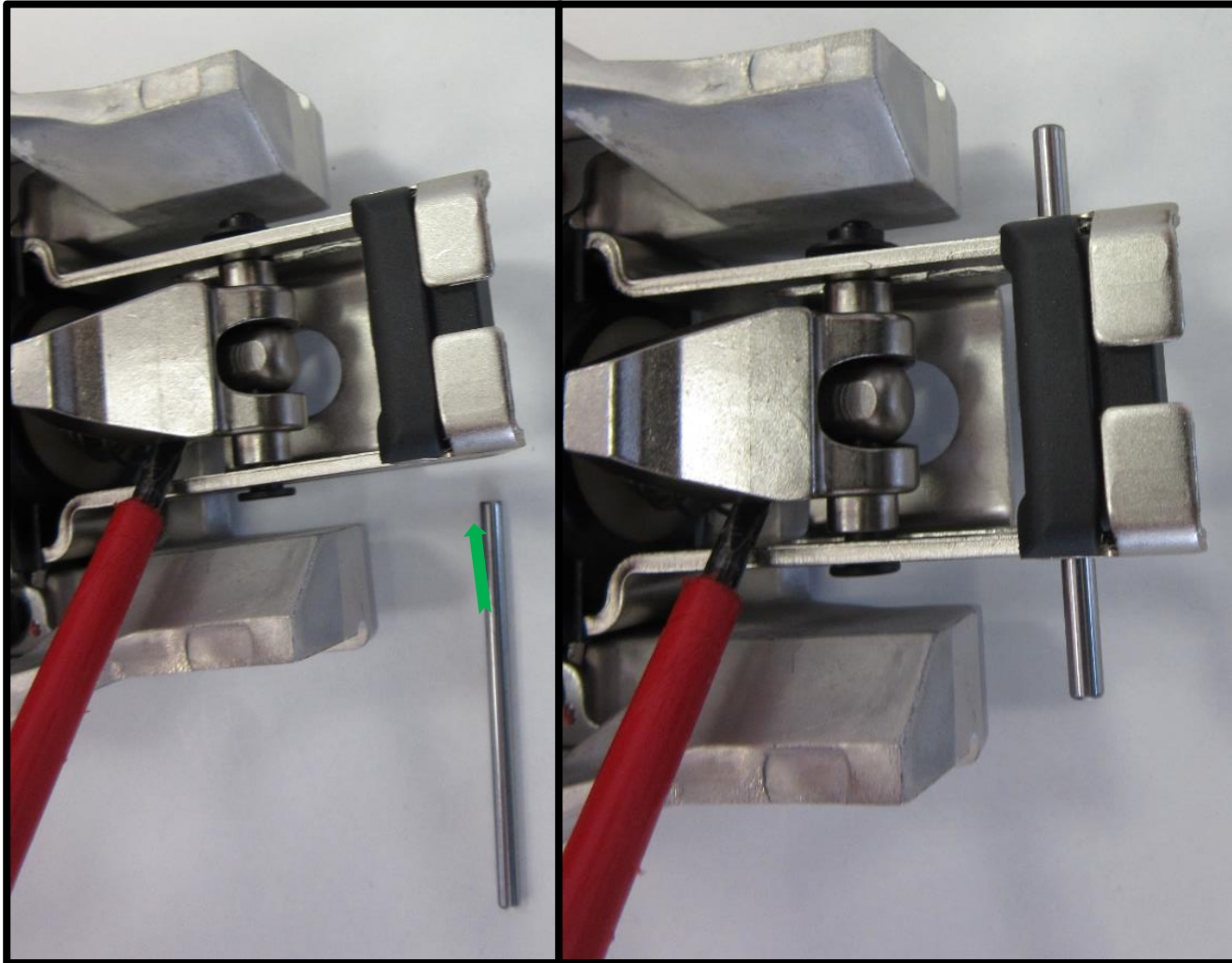

Assembling

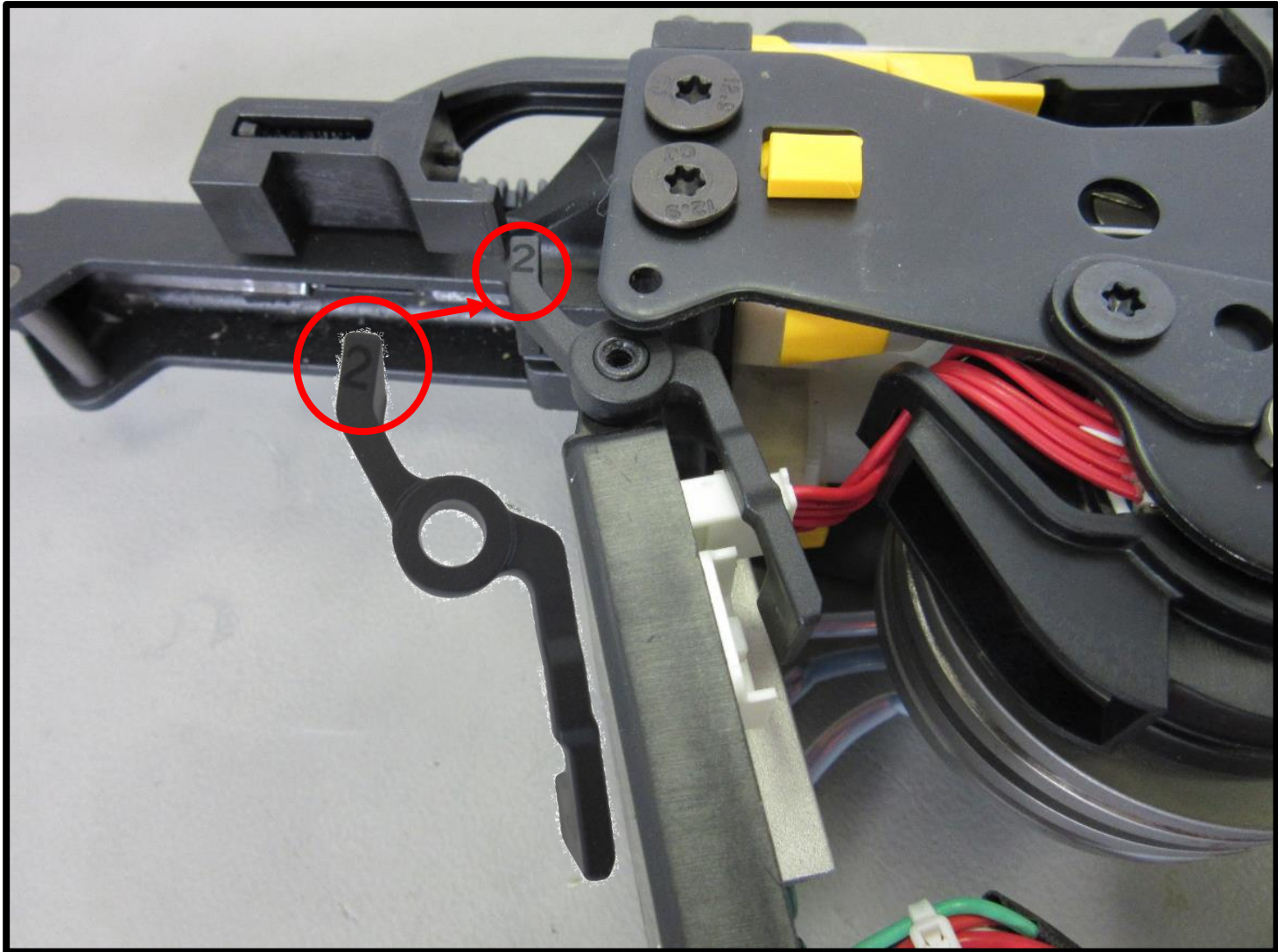

Good to know

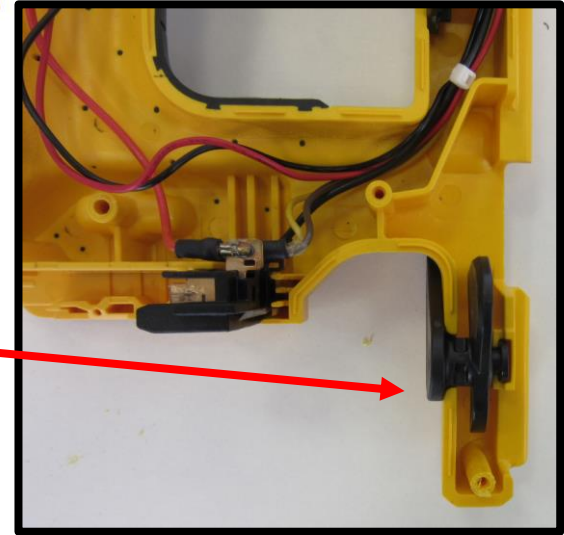
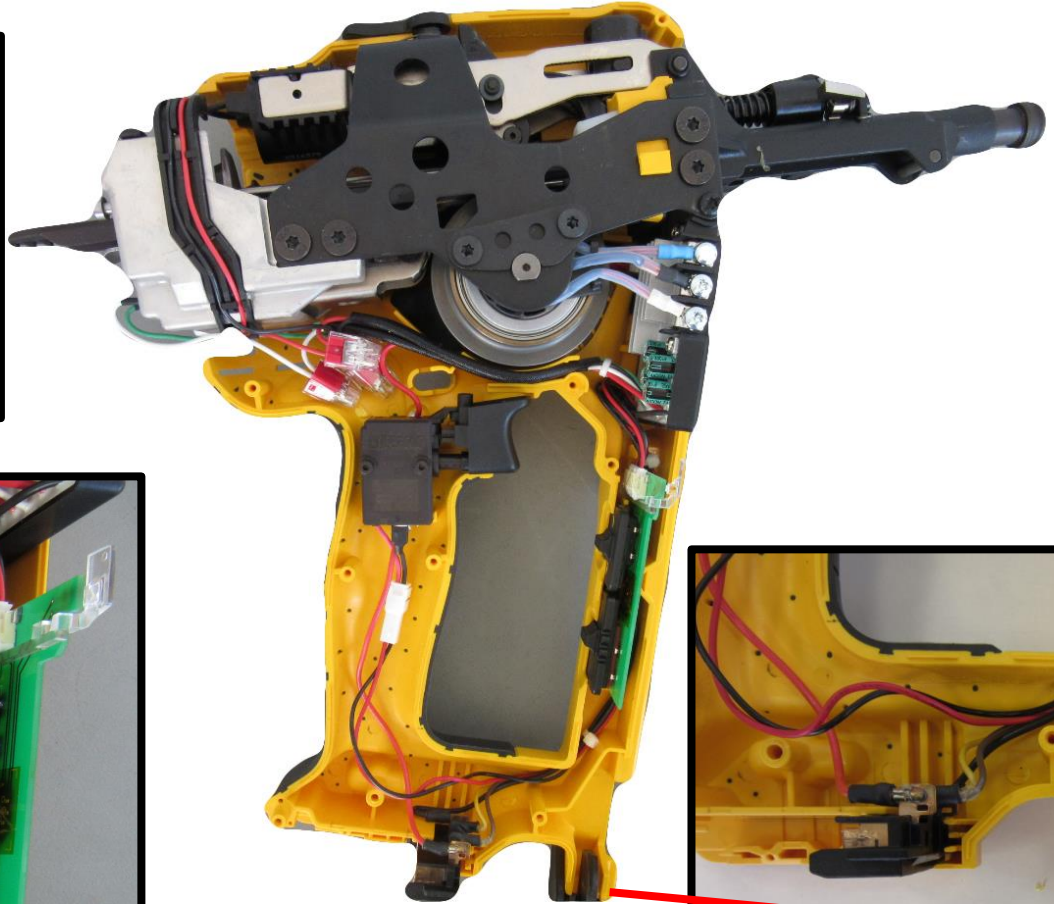
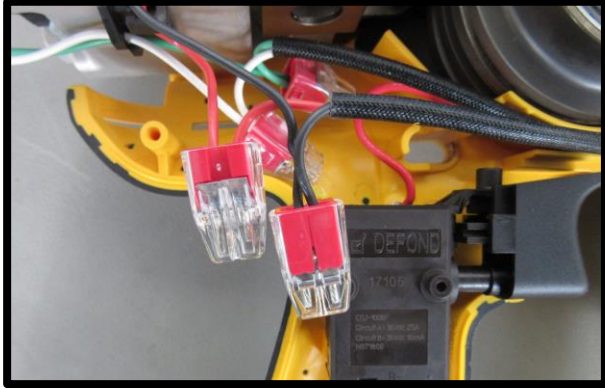

Good to know

The picture shows a CCN profile that has passed conformance tests.

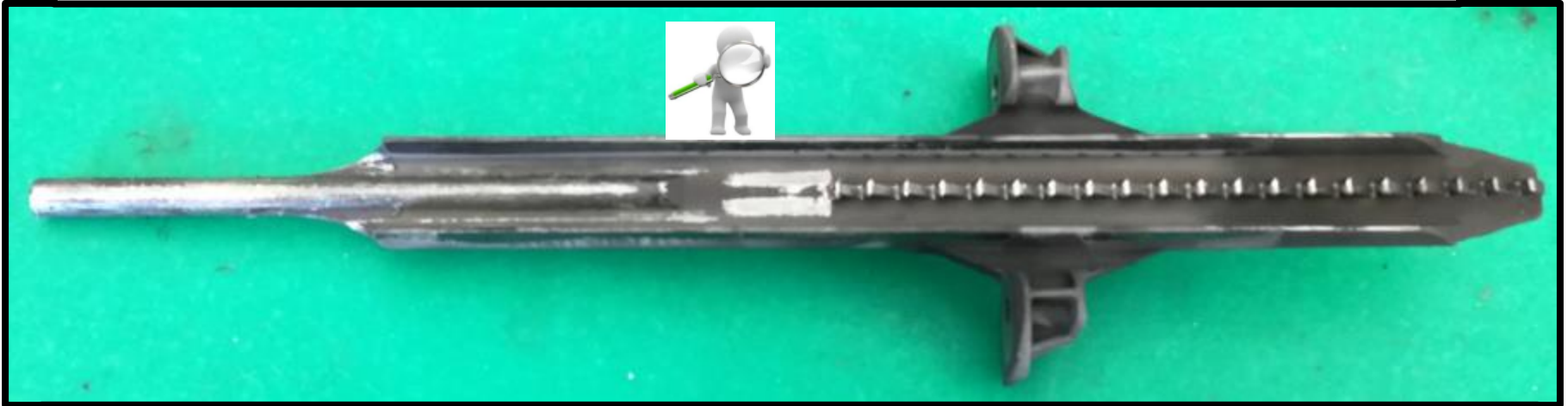

If the return teeth showing wear, replace the profile under a **non warranty** case

Functionally Check

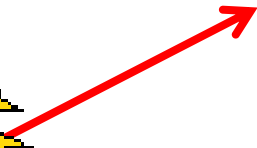
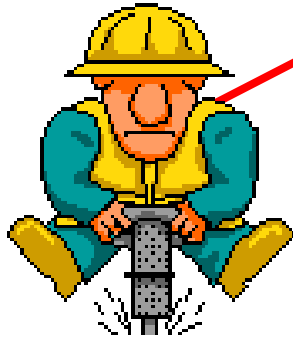
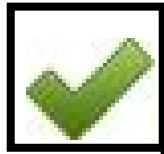



Remember:
**the next check will be
made by your customer**

