

DEWALT

DCLE34030

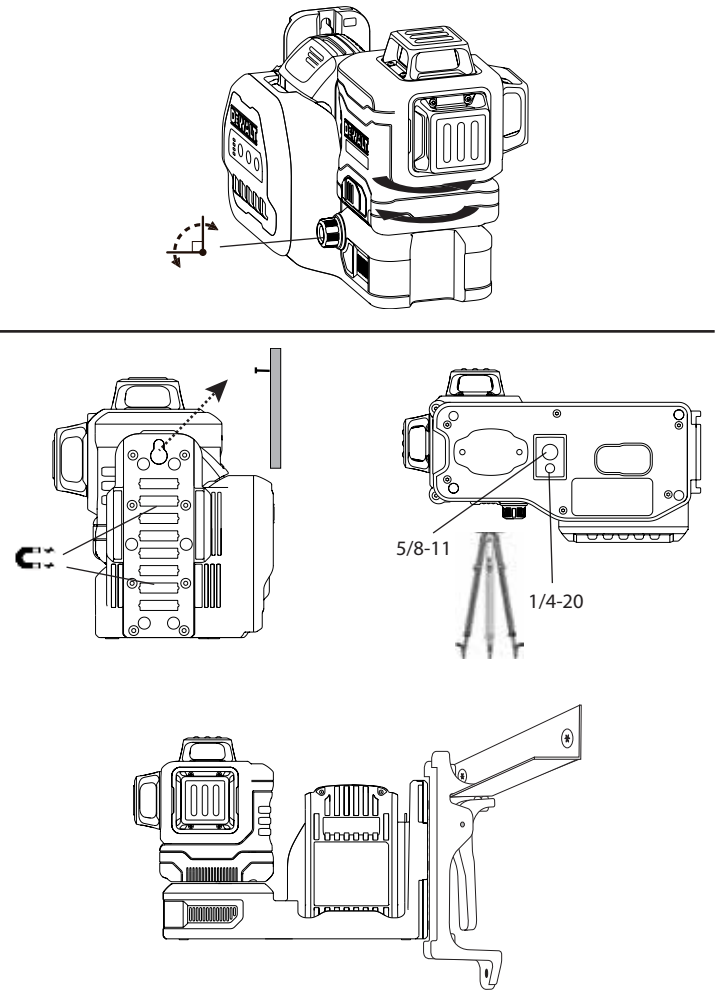

Checking Accuracy ① → ④

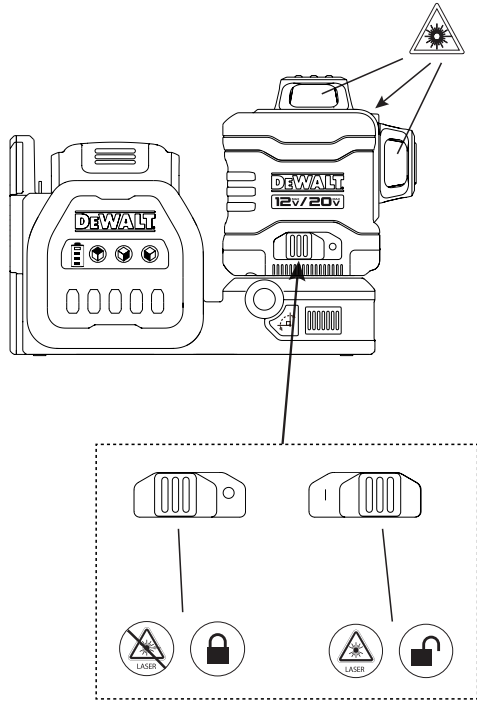
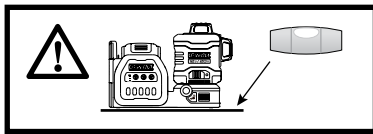

ES Comprobación de la precisión
FR Vérification de la précision
PT Verificação da Precisão

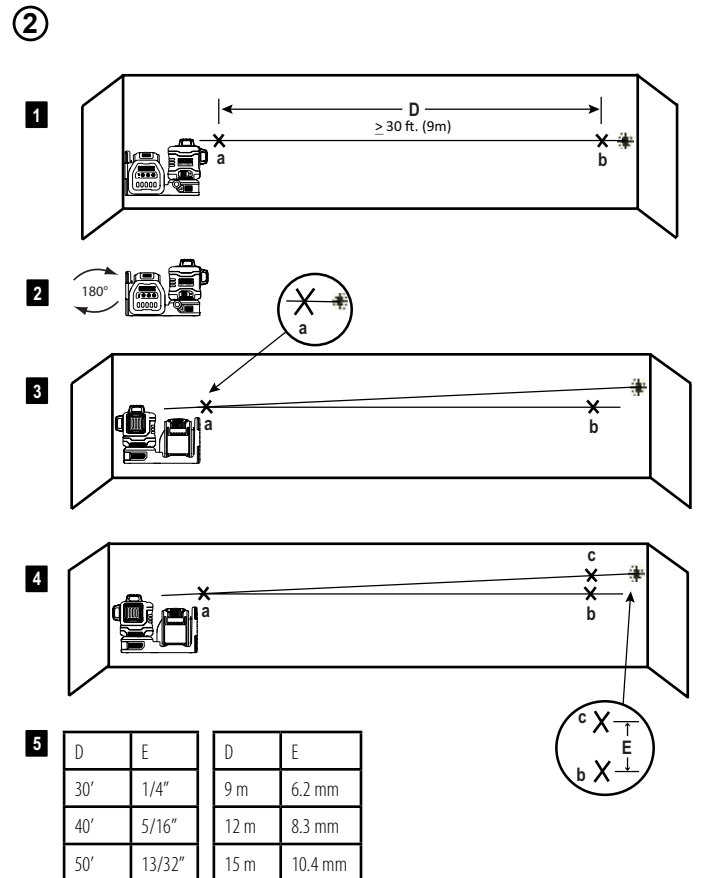
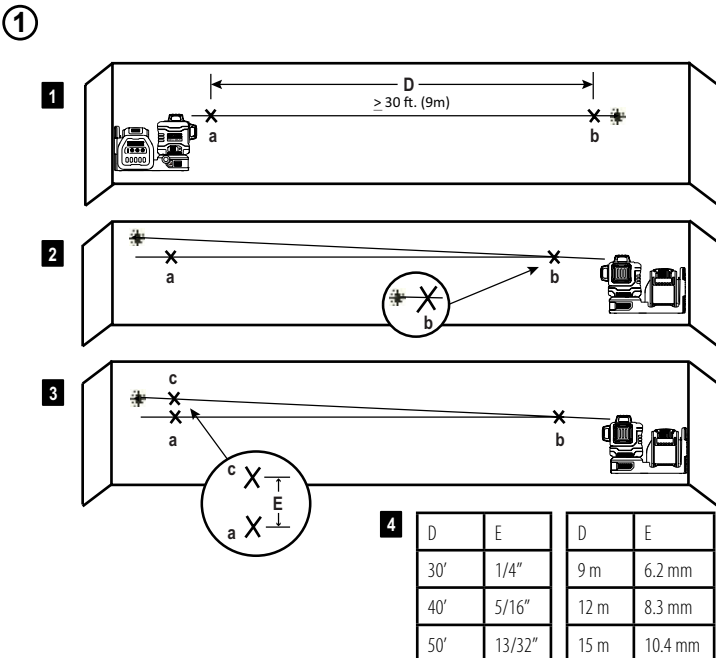

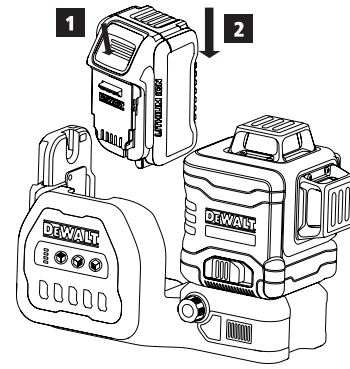
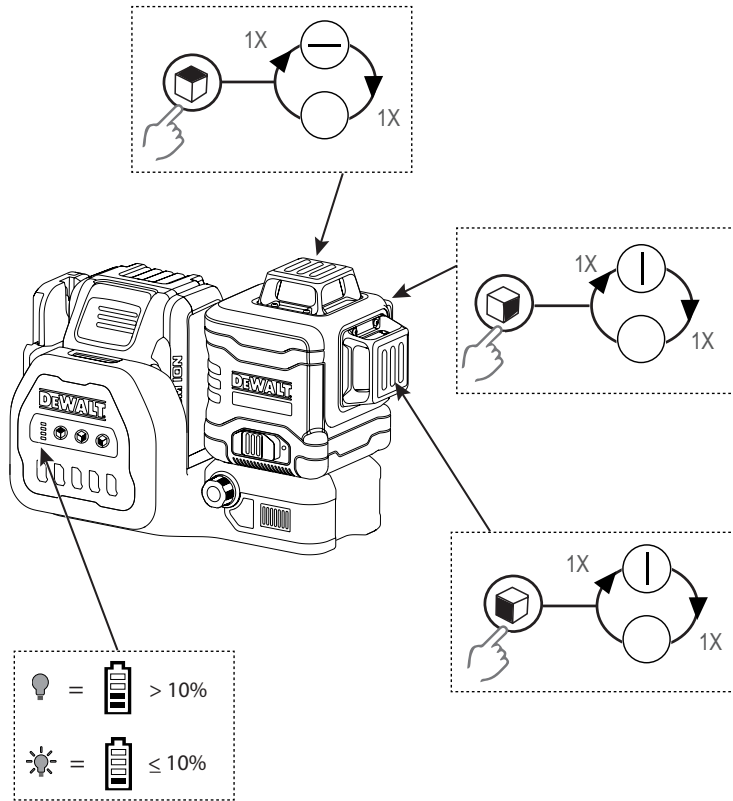

© 2020 DEWALT Industrial Tool Co.
701 East Joppa Road
Towson, Maryland 21286
www.DEWALT.com



9/2020

N856409

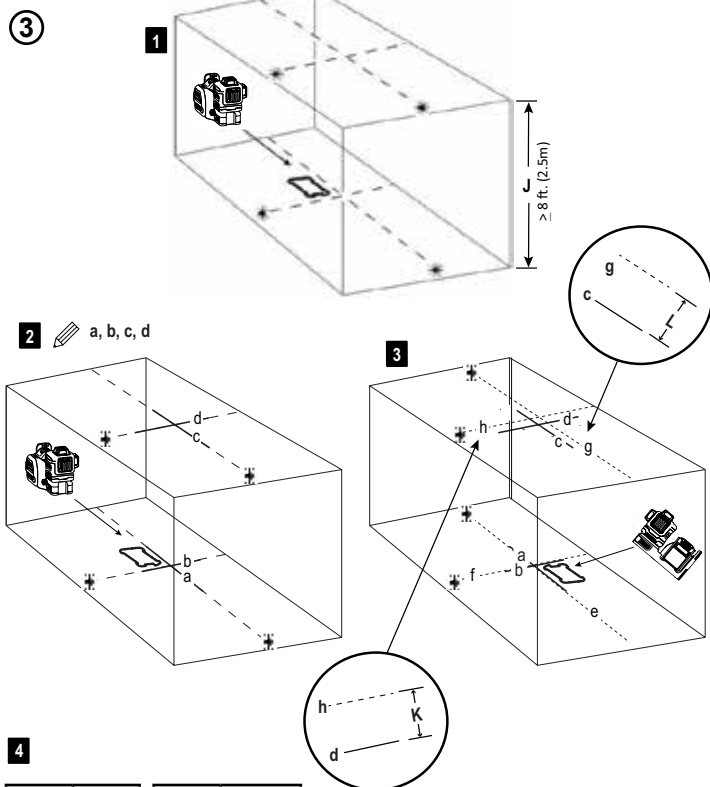

J	K, L	J	K, L
8'	1/16"	2.5 m	1.7 mm
10'	3/32"	3.0 m	2.1 mm
14'	1/8"	4.0 m	2.8 mm
18'	5/32"	6.0 m	4.1 mm
30'	1/4"	9.0 m	6.2 mm

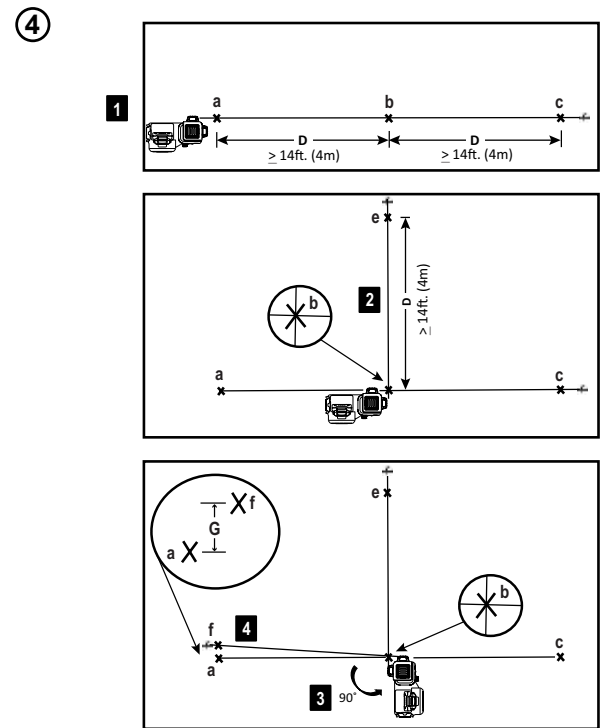

D	G	D	G
14'	5/32"	4.0 m	3.5 mm
17'	3/16"	5.0 m	4.4 mm
20'	7/32"	6.0 m	5.3 mm
23'	1/4"	7.0 m	6.2 mm