

STANLEY BOSTITCH

ORIGINAL PRINT
DO NOT TAKE FROM
ENG. DEPT. DATE 6-26-98
FILE WITH TRACINGS

Model
FC95EC

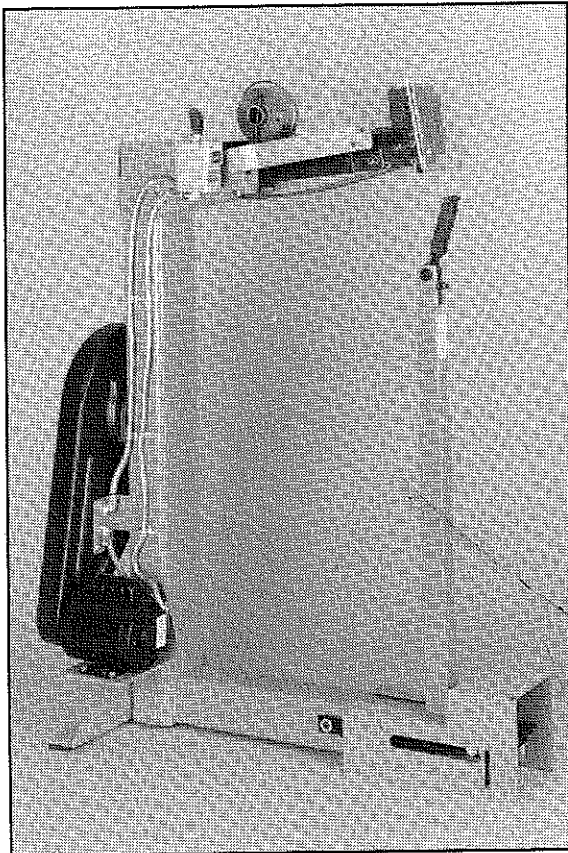

Model
FC95ECARM

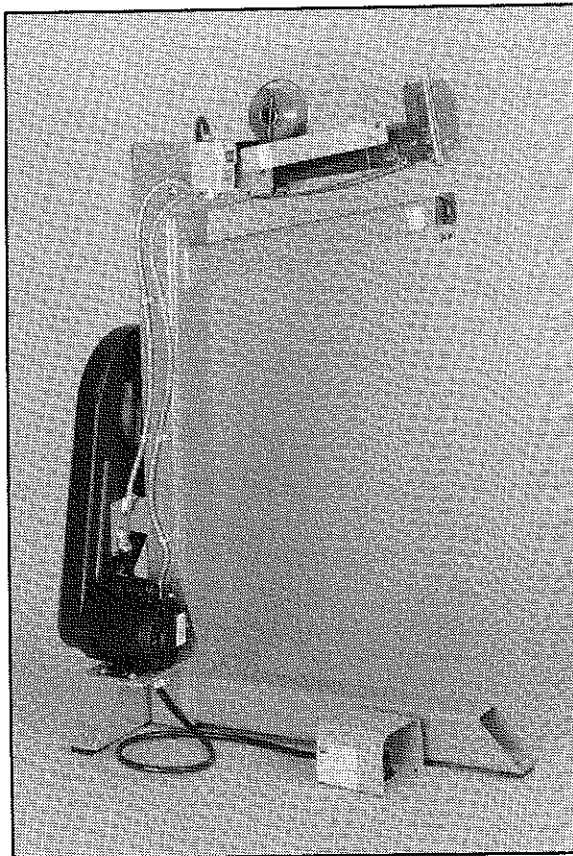

Staplers

OPERATION and MAINTENANCE MANUAL

▲ WARNING:

BEFORE OPERATING THIS TOOL, STUDY THIS MANUAL AND UNDERSTAND THE SAFETY WARNINGS AND INSTRUCTIONS. IF YOU HAVE ANY QUESTIONS, CONTACT YOUR STANLEY-BOSTITCH REPRESENTATIVE OR DISTRIBUTOR. SAVE THESE INSTRUCTIONS FOR FUTURE REFERENCE.

FAST, EASY RELOADING
4000 STAPLES IN EACH
COIL

USES STAPLES:
SWC 7437 $\frac{1}{2}$
SWC 7437 $\frac{5}{8}$
SWC 7437 $\frac{3}{4}$

ADJUSTABLE
CLINCHER

MODEL FC95EC
FEATURES A
PIVOTING CLINCHER
POST FOR EASY
PLACEMENT AND
REMOVAL OF
CARTON OVER
CLINCHER

ELECTRIC CLUTCH
AND FLYWHEEL
WITH V-BELT DRIVE
FOR SMOOTH
QUIET OPERATION

ADJUSTABLE LENGTH
FOOT PEDAL FOR
OPERATOR COMFORT
AND EFFICIENCY

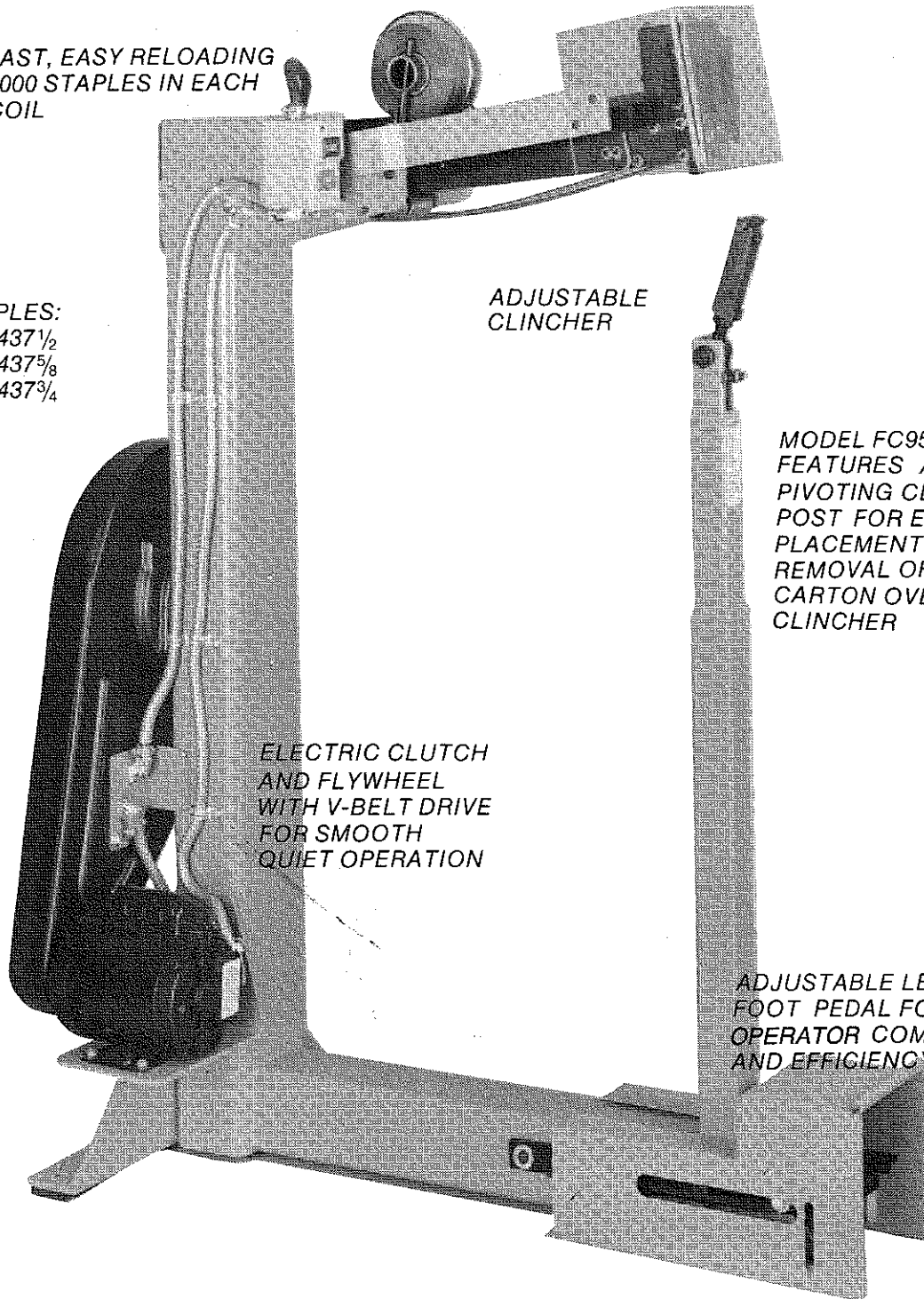

FC95EC Specifications

Length 41" (104 cm)

Height 53 $\frac{1}{2}$ " (136 cm)

Width 22 $\frac{3}{4}$ " (58 cm)

Weight 230 lbs. (104 kg)

Model FC95EC features a pivoting clincher post for easy placement and removal of carton over clincher.

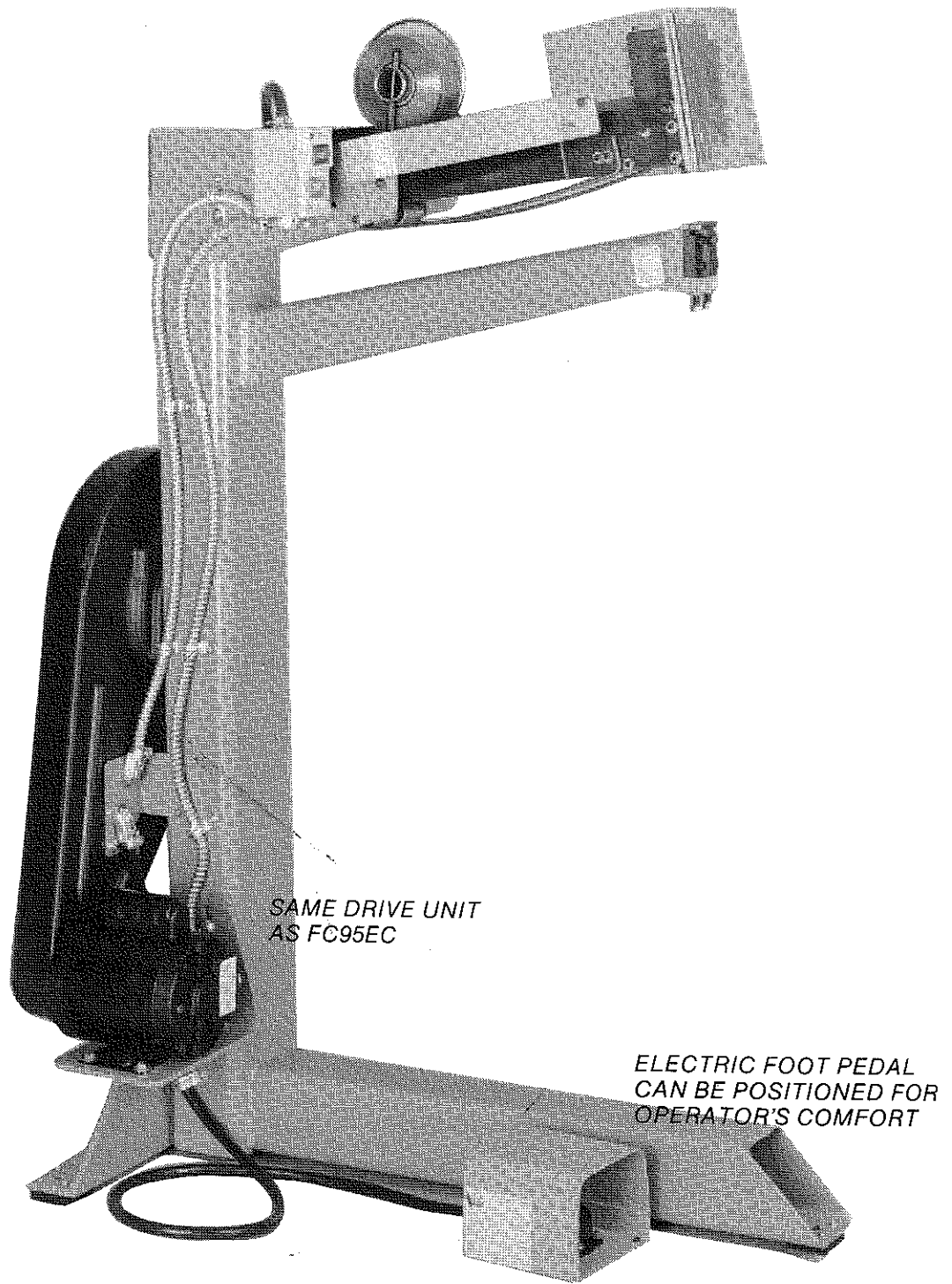

FC95ECARM Specifications

Length 41" (104 cm) Height 53½" (136 cm) Width 22¾" (58 cm) Weight 225 lbs. (102 kg)

Model FC95ECARM features a clincher arm for stapling flat work.

INTRODUCTION

The Stanley-Bostitch FC95EC box bottoming stapler is a precision-built machine designed for high speed, high volume carton bottoming. Also available is an arm version, FC95ECARM for stapling flat work. These coil fed staplers will deliver efficient, dependable service when used correctly and with care. As with any fine machine, for best performance the manufacturer's instructions must be followed. Please study this manual before operating the bottomer and understand the safety warnings and cautions. The instructions on installation, operating and maintenance should be read carefully and the manual kept for reference. Note: additional safety measures may be required because of your particular application of the bottomer. Contact your Stanley-Bostitch representative or distributor with any questions concerning the bottomer and its use.

CAUTION: Never operate machine without board above the clincher as damage may result to driver and door assembly.

CAUTION: Make sure the set screw in the clincher holder is facing forward so that it may be tightened against the flat on the clincher post. Never tighten the set screw against the threads on the clincher post as damage may be done to the threads resulting in jamming the clincher holder during adjustment.

CAUTION: Do not oil excessively as this will result in the work becoming oil spotted.

BEFORE USING THE FC95EC OR FC95ECARM BE AWARE OF THE FOLLOWING WARNINGS:

DO NOT place hands between stapler head and clincher when operating machine.

When manually feeding staples into head **DO NOT** grip sharp edges of staple belt. Place finger tips on center of belt and push belt forward to feed.

INDEX

	<u>PAGE</u>
Machine Operation	5
Lubrication	6
Parts List FC95EC	9
Parts List FC95ECARM	11
Electrical Parts List	12,13
Parts List for FC9500EC Stapling Head	14
Maintenance	16
Clutch and Brake Unit	18
Warranty	Back Cover

OPERATING THE FC95EC and FC95ECARM STAPLERS

LOADING

1. Make certain power switch is off.
2. Slide coil holder off magazine studs and slide coil onto spindle.
3. Feed staples under top guide and oiler felts until the lead end strikes the door assembly.
4. Switch power on and depress foot pedal for one cycle. Machine is now ready for stapling.

NOTE: If belt of staples should break, run the machine until it stops feeding staples. Reload as described above.

- In operating the stapler be careful not to drive one staple over another as damage may be done to the driver.
- Staple Jams - Most jams are easily cleared by removing the door from the front of the head and removing the jammed staple(s) with needle nose pliers. If the head binds against the work, the head must first be raised off the work. See note under maintenance for manually cycling machine. With head raised, remove door and jammed staple.

▲ WARNING: If head is not in its raised position after jam is cleared, it will return to its normal position when the machine is turned on. Stand clear of stapling head when turning machine on.

NOTE: Use only staples recommended by Stanley-Bostitch for use in FC95EC and FC95ECARM or staples which meet Stanley-Bostitch requirements.

INTERLOCK

The FC9500EC head is equipped with an interlock. This mechanism prevents serious damage to the head by preventing the driving of two staples at one time. The driver stop prevents a second staple from being ejected into the staple channel and causing a jam if the head has previously completed its stroke without the post in clinching position. The interlock is engaged when the driver has moved down about $\frac{1}{4}$ ". The interlock disengages when the driver has reached the bottom of the stroke.

ADJUSTING FOR THICKNESS OF WORK

Try a sample of work to be stapled. If the clinch is not satisfactory, adjustment must be made. See chart on page 6 .

NOTE: Machines are shipped from the factory set for two thicknesses of C-flute single wall corrugated board.

1. FC95EC

- a. Loosen the set screw in the clincher holder and the hex jam nut sufficiently to turn the clincher holder.
- b. Turn the clincher holder approximately two turns clockwise (lower) if the machine clinches too tight or counter-clockwise (raise) if the clinch is too loose.
- c. Stapler is properly adjusted when interlock in head disengages at bottom of stroke.
- d. Tighten set screw. Try a sample of work to be stapled. If machine still clinches too tight or too loose, continue to adjust height of clincher until required adjustment is obtained.
- e. Tighten hex jam nut.

2. FC95ECARM

- a. Loosen four clincher mounting screws and the jam nuts on the adjusting screws.
- b. Turn the adjusting screws approximately two turns counter-clockwise if the machine clinches too tight. This will lower the clincher.
- c. Turn the adjusting screws approximately two turns clockwise if the clinch is too loose. This will raise the clincher.
- d. Stapler is properly adjusted when interlock in head disengages at bottom of stroke.
- e. Tighten clincher mounting screws.
- f. Try sample of work to be stapled. Continue to raise or lower clincher until required adjustment is obtained.
- g. Tighten adjusting screw jam nuts.

CLINCHER LATERAL ADJUSTMENT

1. This adjustment is best done without staples in the head.
2. Loosen clincher retaining plate.
3. Lower the head and centralize clincher. Tighten screw.







NOTE: The head is lowered as follows. With the machine off and the power disconnected, remove the belt guard cover. Manually lift the solenoid actuated lever off the electric clutch. Manually turn the flywheel counter-clockwise engaging the clutch and lowering the head until it is flush with the clincher allowing the adjustment described above.

⚠ WARNING: After adjustment is complete manually turn flywheel until head returns to its rest position. If this is not done, the head will return to its normal position when the machine is turned on. Stand clear of stapling head when turning machine on.

LUBRICATION

1. Use an S.A.E. #10 oil. (Refer to lubrication diagram on the following page for points of oil.) Machines in constant use should be oiled daily. Machines operated occasionally should be oiled just prior to operation.
2. Usually only a few drops of oil are required at each point of lubrication. Lubricate regularly instead of excessively. Excessive oiling will result in work becoming oil spotted.
3. Saturate head oiler felts with oil until oil is visible on bottom side. Repeat this process each time a new coil of staples is loaded or each time machine has been idle for some time which would allow felts to dry out.
4. **NOTE: DO NOT OIL CLUTCH ASSEMBLY.** Unit is permanently lubricated and extra oil will cause malfunctions.

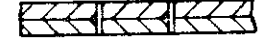
SUGGESTIONS FOR CORRECTING STAPLING PROBLEMS

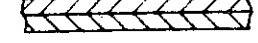
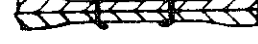
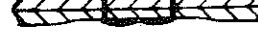
ILLUSTRATION	TROUBLE	CAUSE	CORRECTION
	Good Clinch. Slight carton compression.		
	Clinch too tight. Excessive carton compression. Machine pounds excessively.	Clincher set too high.	Lower clincher.
	Loose clinch.	Clincher set too low.	Raise clincher.
	Buckled crown on 3/4 leg staple.	Worn door.	Replace worn door.
	Staple pierces work but returns with head.	Clincher set too low.	Raise clincher.
	Staple penetrates board but buckles at crown.	Poor alignment of clincher.	Realign clincher.
	Machine operates but staples do not enter board.	Staples jammed in door.	Remove door and remove jammed staples. Do not operate the machine without work on the clinchers.
	Clinch too short.	Staple leg too short for thickness of work.	Use next longer leg length staple.
	Crown collapses.	Staple leg too long for thickness of work.	Use next shorter leg length staple.

LUBRICATION DIAGRAM FC95EC AND FC95ECARM

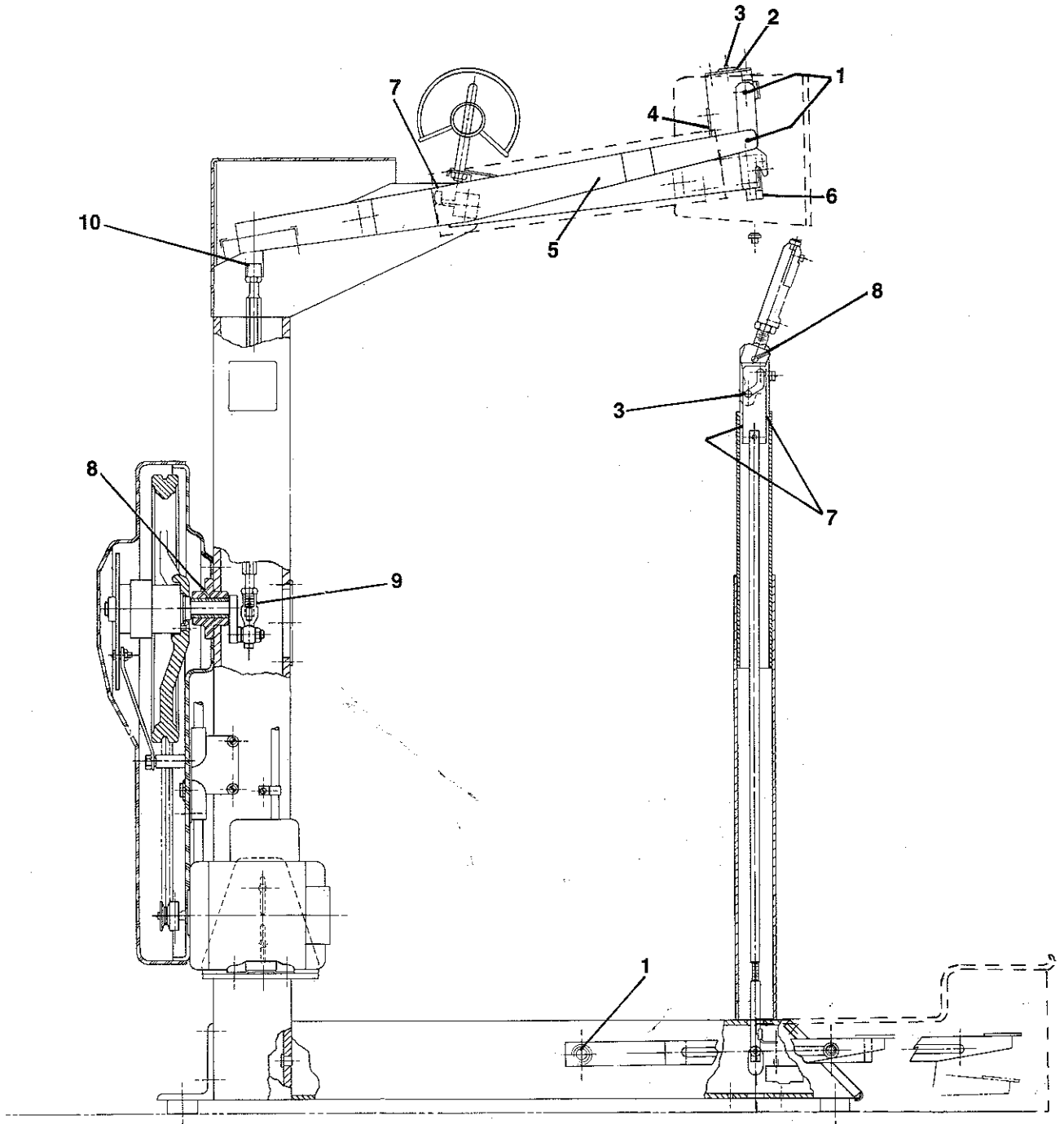

ITEM NO.	DESCRIPTION	ITEM NO.	DESCRIPTION
1	Oil (both sides)	6	Remove door & oil both sides of anvil behind pusher
2	Oil (through two holes)	7	Oil (front & rear edges of clincher arm)
3	Oil	8	Oil (through hole)
4	Grease front & rear surface of driver stop lightly	9	Grease rod end daily
5	Oil (two felt strips)	10	Grease rod end weekly

FC95EC

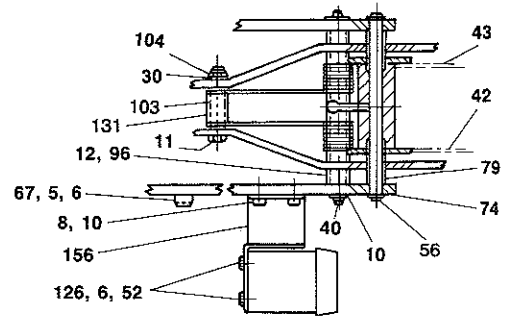

Section A-A

Section D-D

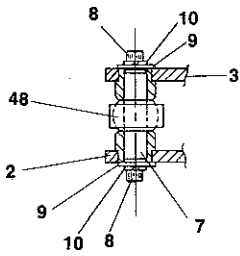

118, 119, 120, 121
122, 123, 124, 94

126, 127, 10, 23

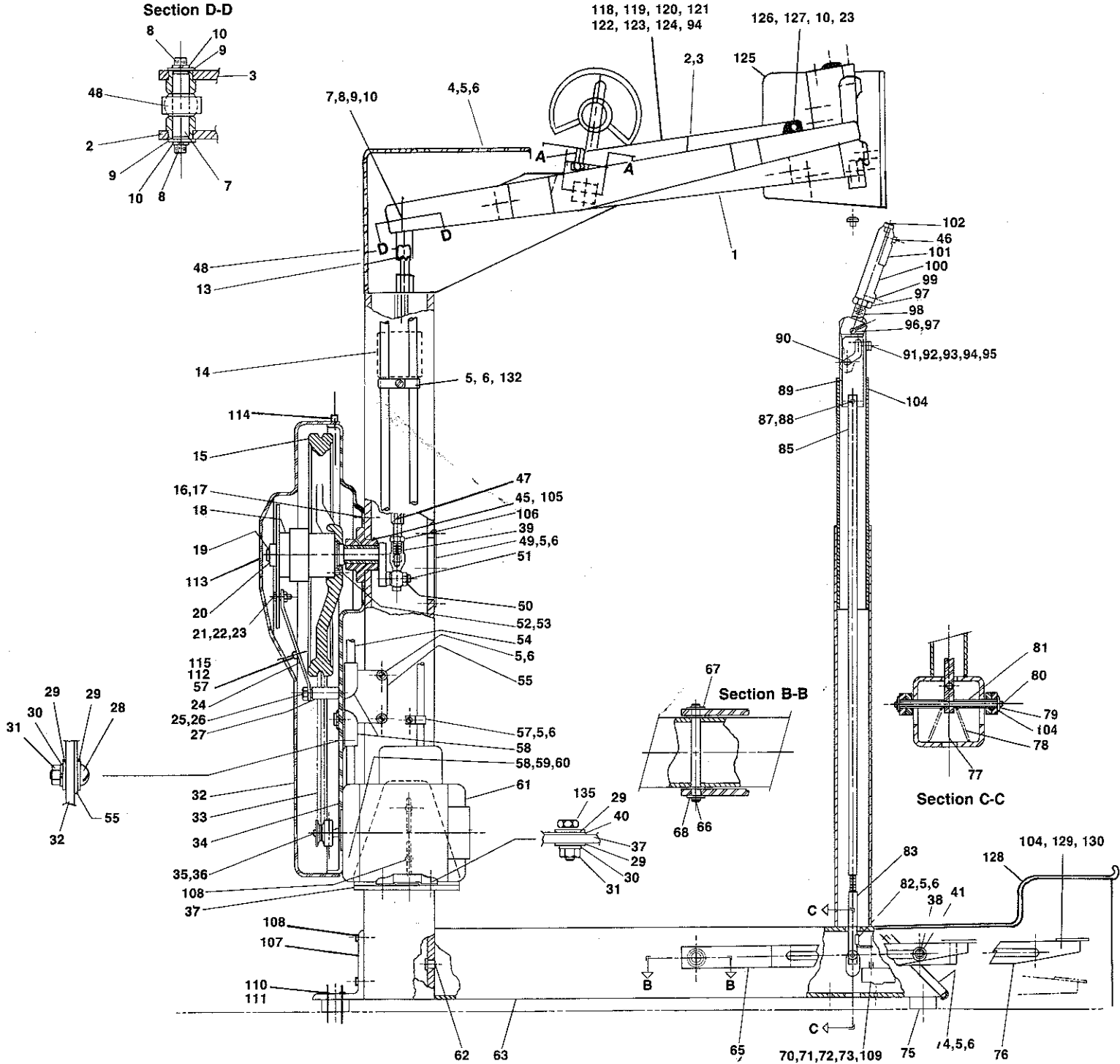

FC95EC PARTS LIST

ITEM NO.	PART NO.	DESCRIPTION	ITEM NO.	PART NO.	DESCRIPTION
1	FC9500EC	Golden Belt Stapling Head	69	FC9615	Pivot Spacer
2	FC136A	Link Arm Assembly (L.H.)	70	851768	Microswitch
3	FC137A	Link Arm Assembly (R.H.)	71	36593	Microswitch Shield
4	FC9689	Head Mount Guard	72	UA1816	6-32" x 1" Hex Socket Head Cap Screw
5	UA3308.4	10-24" x 1/2" Slotted Rd. Head Machine Screw	73	SW6	#6 Lock Washer
6	SW10	Lock Washer	74	FC9655	Cover, Front Leg
7	FC140	Bearing Pin	75	FC9657	Vibration Pad
8	UA4808.3	1/4-20" x 1/2" Hex Socket Head Cap Screw	76	FC9652W	Pedal Extension Complete
9	PW14.4	Plain Washer	77	UB2108.2	1/8" x 1/2" Roll Pin
10	LW14	Lock Washer	78	FC246	Conical Compression Spring
11	UA5140.1	5/16-18" x 2-1/2" Hex Head Cap Screw	79	851309	Retaining Ring
12	FC9619	Head Mount Tie	80	FC9647	Clincher Link Pin
13	HN1220.4	1/2-20" Hex Jam Nut	81	FC9645	Link Spacer
14	E620	Name Plate	82	FC9653	Microswitch Bracket
15	7678	Drive Pulley	83	FC9654	Link Extension
16	UA3810.4	10-24" x 5/8" Hex Socket Head Cap Screw	84	850840	Caution Label
17	PW10	Plain Washer	85	FC234	Clincher Post Link
18	850673	Wrap Spring Clutch Assembly	86	FC9665	Spring Spacer
19	FC9633	Key	87	FC239	Link Pivot Pin
20	851278	Retaining Ring	88	UB1106.1	1/16" x 3/8" Roll Pin
21	7681	Clutch Anchor Screw — Top	89	FC233	Clincher Cam
22	SW14	Lock Washer	90	FC238	Cam Follower Pin
23	HN1420.5	1/4-20" Hex Nut	91	FC237	Clincher Post Stop
24	FC9656	Clutch Anchor	92	UA3808.8	10-24" x 1/2" Hex Socket Head Cap Screw
25	UA8164	1/2-13" x 4" Hex Head Cap Screw	93	LW10	#10 Lock Washer
26	HN1213.2	1/2-13" Hex Jam Nut	94	HN51618.2	5/16-18" Hex Jam Nut
27	FC9632	Anchor Spacer	95	FC9715	Post Stop Stud
28	UA5314.1	5/16-18" x 7/8" Slotted Rd. Head Machine Screw	96	FC236	Clincher Pivot
29	PW516	Plain Washer	97	HN5818.2	5/8-18" Hex Jam Nut
30	LW516	Lock Washer	98	FC232	Clincher Post
31	HN51618	5/16-18" Hex Nut	99	UA5806.6	5/16-18" x 3/8" Hex Socket Set Screw (Flat Point)
32	FC9723	Belt Guard	100	FC201	Clincher Holder
33	850730	"V" Belt	101	FC104	Clincher Retaining Plate
34	FC9724	Belt Guard Mounting Plate	102	FC103B	Clincher
35	FC9620	Motor Pulley	103	FC141	Arm Spacer
36	UA5806.1	5/16-18" x 3/8" Hex Socket Set Screw (Cup Point)	104	PW516.9	Plain Washer
37	FC9659	Motor Bracket	105	UA4116.4	1/4-20" x 1" Hex Head Cap Screw
38	UA6112.1	3/8-16" x 3/4" Hex Head Cap Screw	106	HN1220.5	1/2-20" L.H. Jam Nut
39	851737	Rod End Ball Joint — Left	107	FC9604	Rear Leg
40	UA4814.1	1/4-20" x 7/8" Hex Socket Head Cap Screw	108	UA6112.3	3/8-16" x 3/4" Large Hex Head Cap Screw
41	PW38	3/8 Plain Washer	109	851818	Wire Connector
42	FC260	Rebound Spring R.H.	110	UA2912	#8 x 3/4" Round Head Wood Screw
43	FC261	Rebound Spring L.H.	111	PW8.4	#8 Plain Washer
44	UA4306.1	1/4-20" x 3/8" Slotted Round Head Machine Screw	112	HN1032.2	#10-32 Elastic Stop Nut
45	FC9636A	Bearing Housing Complete	113	851515	BL Warning Label
46	UA4812.1	1/4-20" x 3/4" Hex Socket Head Cap Screw	114	UA3806.21	#10-24 Self-Tap, Pan Head Screw
47	FC9629	Push Rod	115	UA3308.2	#10-32 Round Head Machine Screw
48	FC143	Rod End Ball Joint	116	88038	Nylon Cable Clamp, 3/8"
49	FC9630	Cover	117	851568	Neo. Tubing
50	HN1220.3	1/2-20" Elastic Stop Nut	118	FC9564A	Arm, RH Guard - Comp.
51	FC9623W	Crank Shaft Complete	119	FC9565A	Arm, LH Guard - Comp.
52	UA4812.7	1/4-20" x 3/4" Hex Socket Flat Head Cap Screw	120	UA8128.1	Screw, 1/2-13 x 1-3/4 Hex Hd. Screw
53	SW14.1	Lock Washer	121	FC9568	Spacer
54	85416	Flexible Conduit (Guard Bracket to Main Column 7)	122	P2152	Plain Washer, 1/2
55	FC9631	Guard Bracket	123	HN1213.5	Nut, 1/2-13 Elastic Stop
56	FC9614	Pivot	124	UA5828.4	Screw, 5/16-18 x 1-3/4 Soc. Set
57	85198	Cable Clamp	125	FC9563	Shield (Guard)
58	85126	90° Angle Conn. (2 @ Guard Bracket, 1 @ Motor, 1 @ Main Column Back)	126	UA4114.1	Screw, 1/4-20 x 7/8 Hex Hd. Cap
59	851329	3/4x1/2" Reducer Bushing	127	P2126	Plain Washer, 1/4
60	851330	3/4" Lock Nut	128	FC9703	Foot Guard Assembly
61	851981	Motor	129	FC9704	Pin, Foot Guard
62	FC9658	Nylon Bearing	130	851309	Retaining Ring
63	FC9683WELD	Stand Assembly	131	FC9716	Spring Roller
64	86290	Retaining Ring	132	85198	Cable Clamp
65	FC9651W	Foot Pedal Complete	133	FC9719	Starter Bracket
66	FC9674	Pivot Pedal	134	HN1032	10-32 Hex Nut
67	PW12.1	1/2" Plain Washer	135	UA5112.1	5/16-18 x 3/4 HHCS
68	86290	Retaining Ring			

ELECTRICAL PARTS INCLUDED BUT NOT LISTED:

851277 Anti-Short Bushing (1 @ Guard Bracket, 1 @ 90° Conn. Rear Main Column)
 85419 #14 Wire White (Solenoid to Microswitch 60")
 85417 #14 Wire Black (Guard Bracket to Microswitch 53")

850603 Wire Terminal (2 White @ Solenoid)

SEE PAGE 12 FOR ADDITIONAL FC95EC ELECTRICAL PARTS.

FC95ECARM

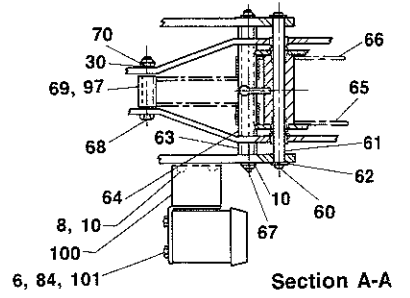

Section B-B

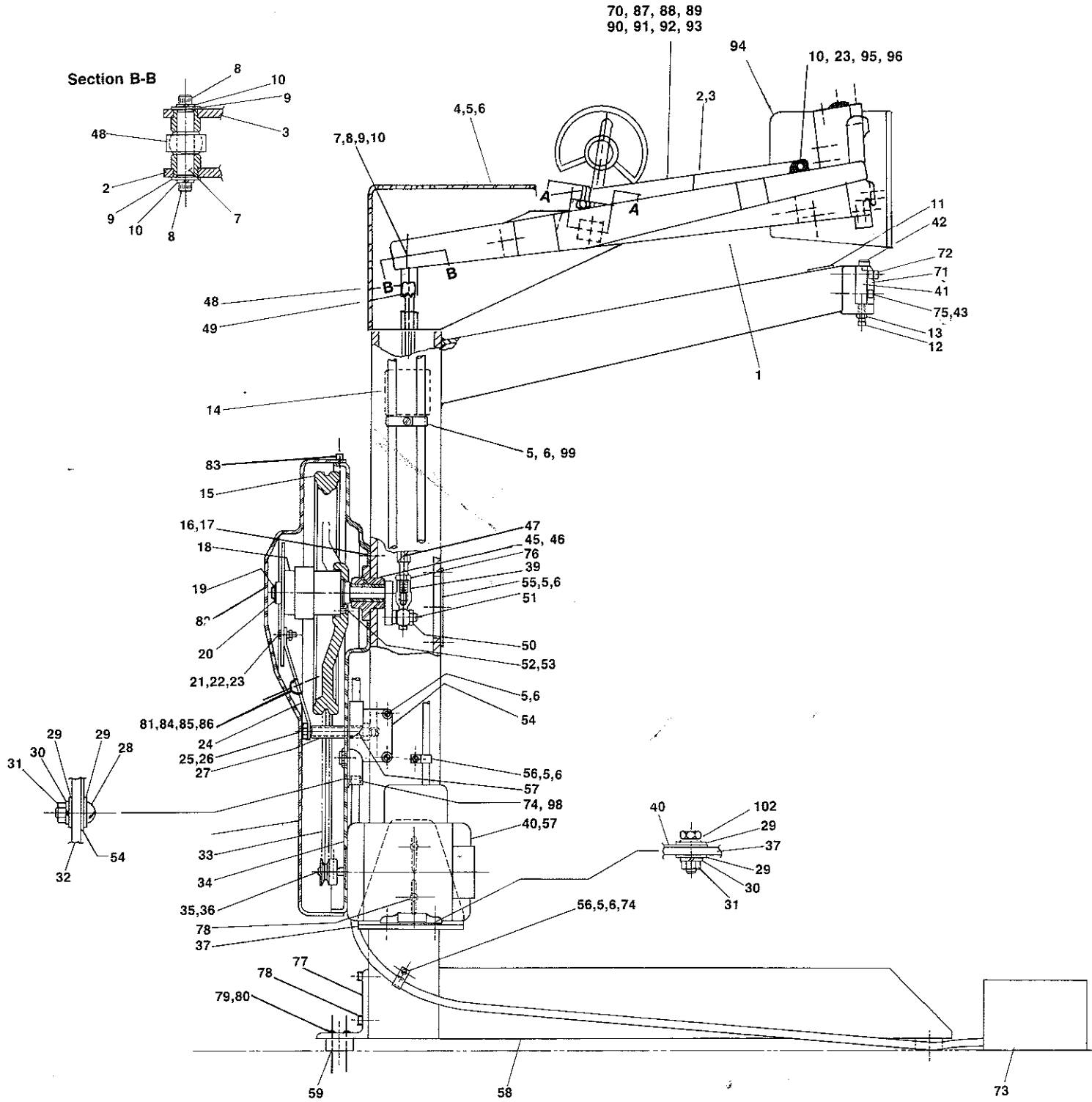
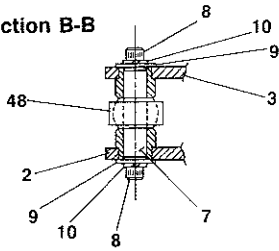

FC95ECARM PARTS LIST

ITEM NO.	PART NO.	DESCRIPTION	ITEM NO.	PART NO.	DESCRIPTION
1	FC9500EC	Golden Belt Stapling Head	52	UA4812.7	1/4-20" x 3/4" Hex Socket Flat Head Cap Screw
2	FC136A	Link Arm Assembly (L.H.)	53	SW14.1	Lock Washer
3	FC137A	Link Arm Assembly (R.H.)	54	FC9631	Guard Bracket
4	FC9689	Head Mount Guard	55	FC9630	Cover
5	UA3308.4	10-24" x 1/2" Slotted Round Head Machine Screw	56	85198	Cable Clamp
6	SW10	Lock Washer	57	85126	90° Angle Conn. (1 @ Guard Bracket, 1 @ Motor)
7	FC140	Bearing Pin	58	FC9685WELD	Stand Complete
8	UA4808.3	1/4-20" x 1/2" Hex Socket Head Cap Screw	59	FC9657	Vibration Pad
9	PW14.4	Plain Washer	60	FC9614	Pivot
10	LW14	Lock Washer	61	FC9615	Pivot Spacer
11	851013	Caution Label	62	86290	Retaining Ring
12	UA6520.1	3/8-16" Square Head Set Screw	63	FC9619	Head Mount Tie
13	HN3816.2	3/8-16" Hex Jam Nut	64	FC9665	Spring Spacer
14	E620	Name Plate	65	FC260	Rebound Spring (R.H.)
15	7678	Drive Pulley	66	FC261	Rebound Spring (L.H.)
16	UA3810.4	10-24" x 5/8" Hex Socket Head Cap Screw	67	UA4814.1	1/4-20" x 7/8" Hex Socket Head Cap Screw
17	PW10	Plain Washer	68	UA5140.1	5/16-18" x 2-1/2" Hex Head Cap Screw
18	850673	Wrap Spring Clutch Assembly	69	FC141	Arm Spacer
19	FC9633	Key	70	HN51618.2	5/16-18" Hex Jam Nut
20	851278	Retaining Ring	71	FC104	Clincher Retaining Plate
21	7681	Clutch Anchor Screw — Top	72	UA4812.1	1/4-20" x 3/4" Hex Socket Head Cap Screw
22	SW14	Lock Washer	73	851279	Foot Switch & Cable
23	HN1420.5	1/4-20 Hex Nut	74	F94165	Grommet, Rubber Cable
24	FC9656	Clutch Anchor	75	UA4816.1	1/4-20" x 1" Socket Head Cap Screw
25	UA8164	1/2-13" x 4" Hex Head Cap Screw	76	HN1220.5	1/2-20" L.H. Jam Nut
26	HN1213.2	1/2-13" Hex Jam Nut	77	FC9604	Rear Leg
27	FC9632	Anchor Spacer	78	UA6112.3	3/8-16" x 3/4" Hex Head Cap Screw
28	UA5314.1	5/16-18" x 7/8" Slotted Round Head Machine Screw	79	UA2912	#8 x 3/4" Round Head Wood Screw
29	PW516	Plain Washer	80	PW8.4	#8 Plain Washer
30	LW516	Lock Washer	81	HN1032.2	#10-32" Elastic Stop Nut
31	HN51618	5/16-18" Hex Nut	82	851515	BL Warning Label
32	FC9723	Belt Guard	83	UA3806.21	#10-24" Self-Tap, Pan Head Screw
33	850730	"V" Belt	84	UA3308.2	#10-32" Round Head Machine Screw Slot
34	FC9724	Belt Guard Mounting Plate	85	88038	Nylon Cable Clamp
35	FC9620	Motor Pulley	86	851568	Neo. Tubing 5/16" x 1/16"
36	UA5806.1	5/16-18" x 3/8" Hex Soc. Set Screw (Cup Point)	87	FC9564A	Arm, RH Guard - Comp.
37	FC9659	Motor Bracket	88	FC9565A	Arm, LH Guard - Comp.
38	UA6112.3	3/8-16" x 3/4" Hex Head Cap Screw	89	UA8128.1	Screw, 1/2-13 x 1 3/4 Hex Hd. Cap
39	851737	Rod End Ball Joint Left	90	FC9568	Spacer
40	851981	Motor	91	P2152	Plain Washer, 1/2
41	FC253	Clincher Holder	92	HN1213.5	Nut, 1/2-13 Elastic Stop
42	FC103B	Clincher	93	UA5828.4	Screw, 5/16-18 x 1 3/4 Soc. Set.
43	PW12.5	Plain Washer	94	FC9563	Shield (Guard)
44	UA4306.1	1/4-20" x 3/8" Slotted Round Head Machine Screw	95	UA4114.1	Screw, 1/4-20 x 7/8 Hex Hd. Cap
45	FC9636A	Bearing Housing Complete	96	P2126	Plain Washer, 1/4
46	UA4116.4	1/4-20" x 3/4" Hex Head Cap Screw	97	FC9716	Spring Roller
47	FC9629	Push Rod	98	86198	90° Angle Conn.
48	FC143	Rod End Ball Joint	99	85198	Cable Clamp
49	HN1220.4	1/2-20" Hex Jam Nut	100	FC9719	Starter Bracket
50	HN1220.3	1/2-20" Elastic Stop Nut	101	HN1032	10-32 Hex Nut
51	FC9623W	Crank Shaft Complete	102	UA5112.1	5/16-18 x 3/4 HHCS

*Part 851700 is replaceable interior for footswitch.

ELECTRICAL PARTS INCLUDED BUT NOT LISTED:

851277 Anti-Short Bushing
850603 Wire Terminal (2 White @ Solenoid)

SEE PAGE 13 FOR ADDITIONAL FC95ECARM ELECTRICAL PARTS.

NOTE:

THE PLASTIC HEAD GUARD IS AVAILABLE COMPLETE BY ORDERING FC95K1
AND THE FOOT GUARD ASSEMBLY FOR FC95EC IS AVAILABLE COMPLETE
BY ORDERING FC95ECK2.

ELECTRICAL PARTS FOR FC95EC — 60 CYCLE

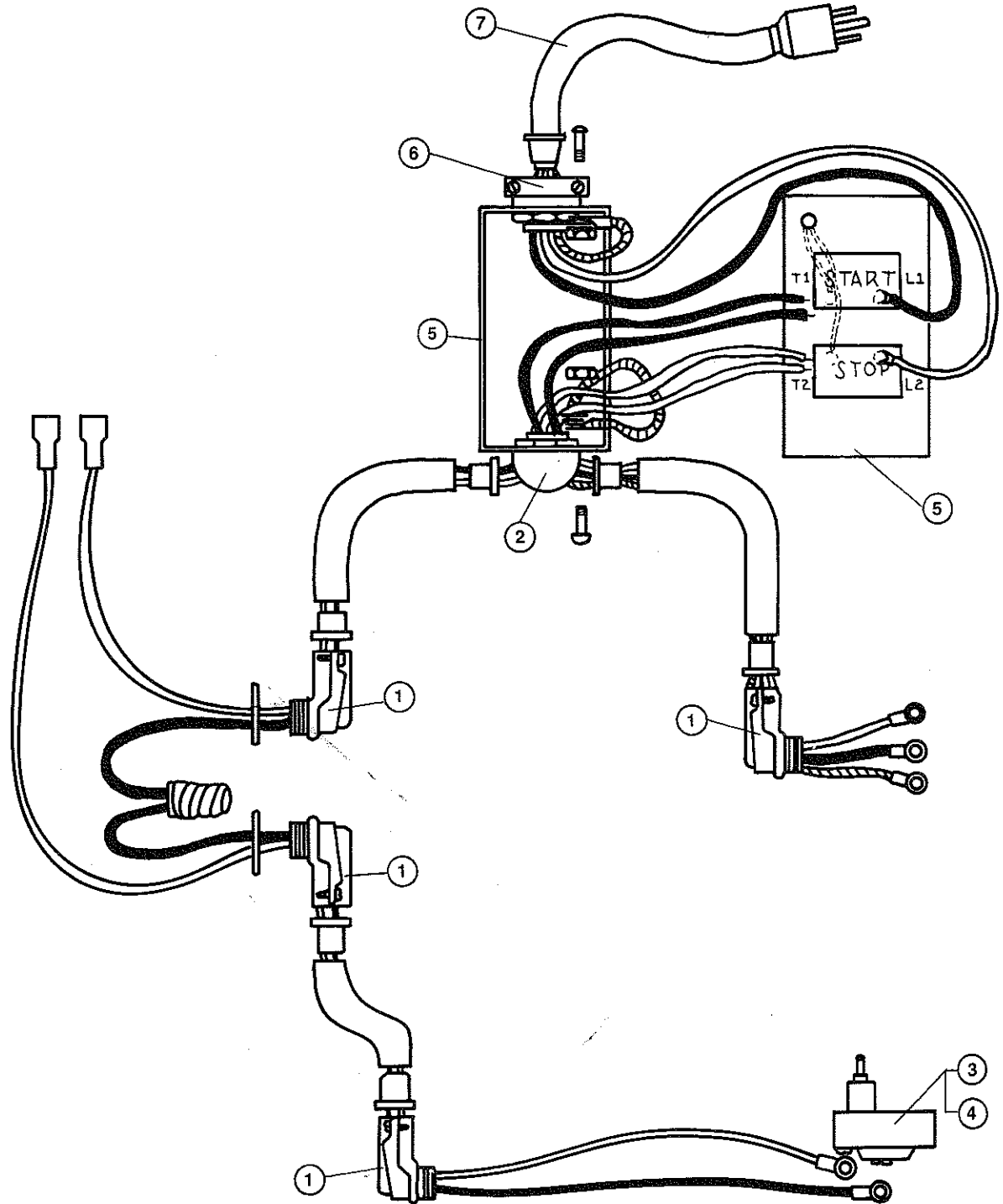

FURNISHINGS

ITEM	PART NO.	QTY.	DESCRIPTION
1	85126	4	90° Angle Connector
2	P11209	1	Duplex Connector
3	851768	1	Microswitch
4	36593	1	Microswitch Shield
5	851738	1	Motor Starter
6	85128	1	Cable Connector
7	86243	1	Power Cord - 125V

ELECTRICAL PARTS FOR FC95ECARM — 60 CYCLE

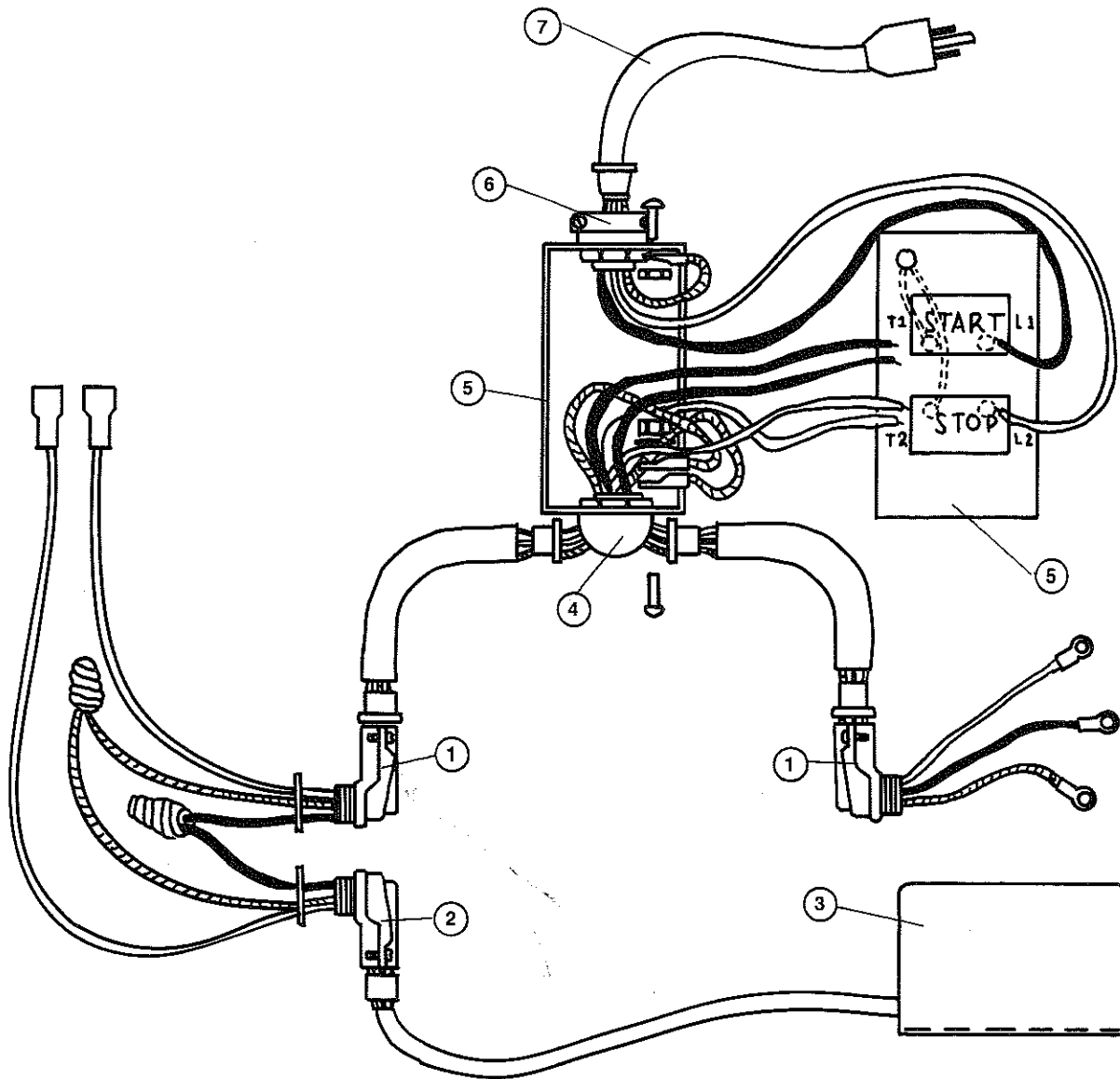

FURNISHINGS

ITEM	PART NO.	QTY.	DESCRIPTION
1	85126	2	90° Connector
2	86198	1	90° Connector
3	851279	1	Foot Switch
4	P11209	1	Duplex Connector
5	851738	1	Motor Starter
6	85128	1	Cable Connector
7	86243	1	Power Cord 125V

ENLARGED VIEW OF HEAD — FC9500EC

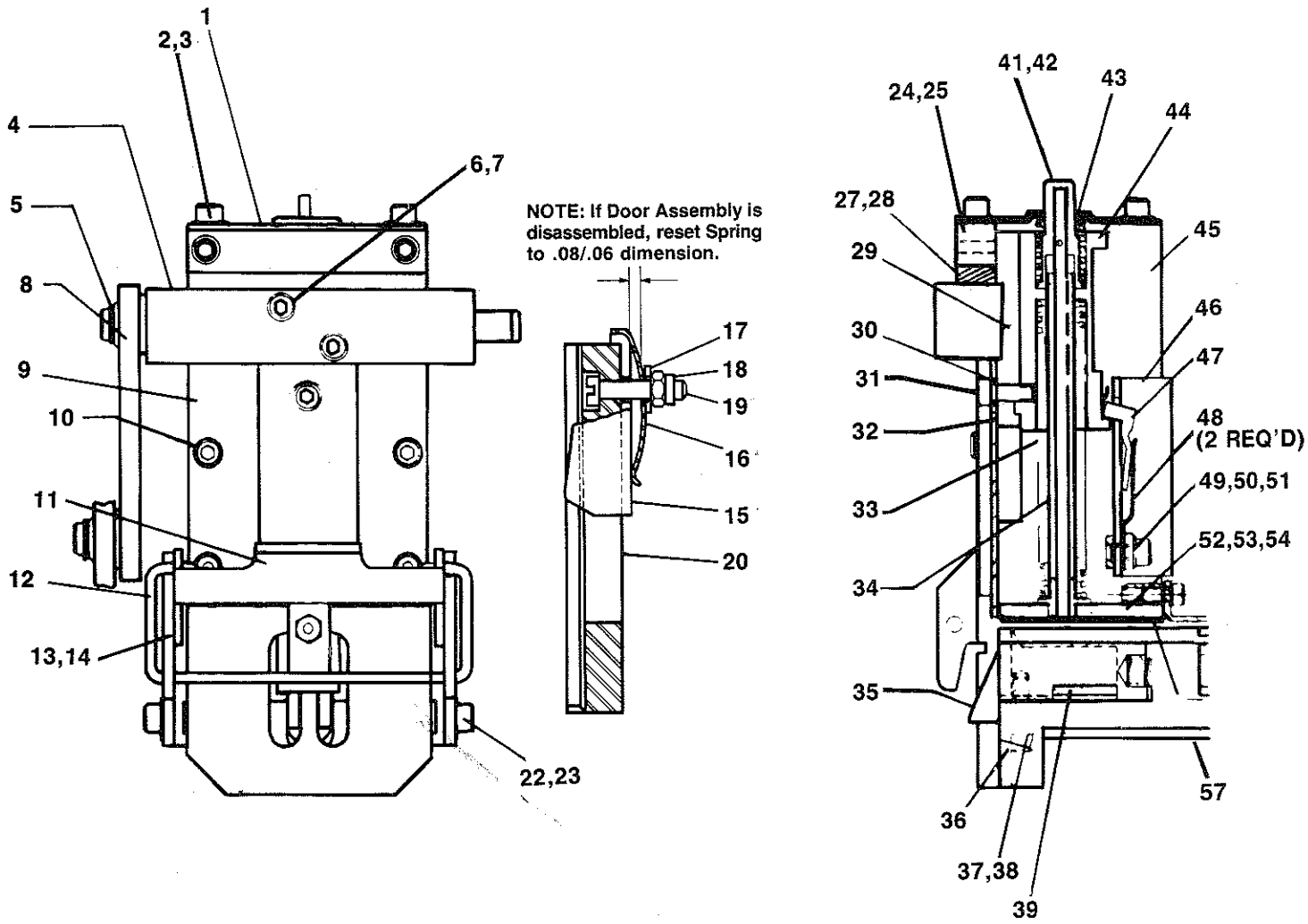

ITEM NO.	PART NO.	DESCRIPTION	ITEM NO.	PART NO.	DESCRIPTION
1	FC9712	Top Guide Plate	20*	FC9528DA	Door Assembly
2	UA3806.3	Screw	22	UA3808.1	Screw
3	SW10E.2	Lock Washer	23	SW10E.2	Lock Washer
4	FC9548A	Cross Bar Assembly	24	FC9711	Bumper Block
5	85017	Retaining Ring	25	UB3014	Roll pin
6	UA3820	Screw	27	FC9505	Bumper
7	SW10	Lock Washer	28	UA3806.9	Screw
8	FC9527A	Drive Link Assembly	29	FC9506	Former
9	FC9517	Front Plates	30	FC9516	Driver Spacer
10	UA3806.3	Screw	31	UA3808.1	Screw
11	FC9531A	Latch Assembly	32	FC9515	Driver
12	FC9533	Latch Spring	33	FC9514	Return Spring
13	FC9530	Latch Plate L.H.	34	FC9508A	Guide Tube Assembly
14	FC9529	Latch Plate R.H.	35	FC9522	Supporter
15*	FC9534B	Supporter	36	FC258	Anvil Support
16*	FC9536	Spring	37	UA3808.1	Screw
17*	PW5.1	Washer	38	SW10E.2	Lock Washer
18*	HN540.2	Nut	39	FC9521	Pusher
19*	FC9561	Screw			

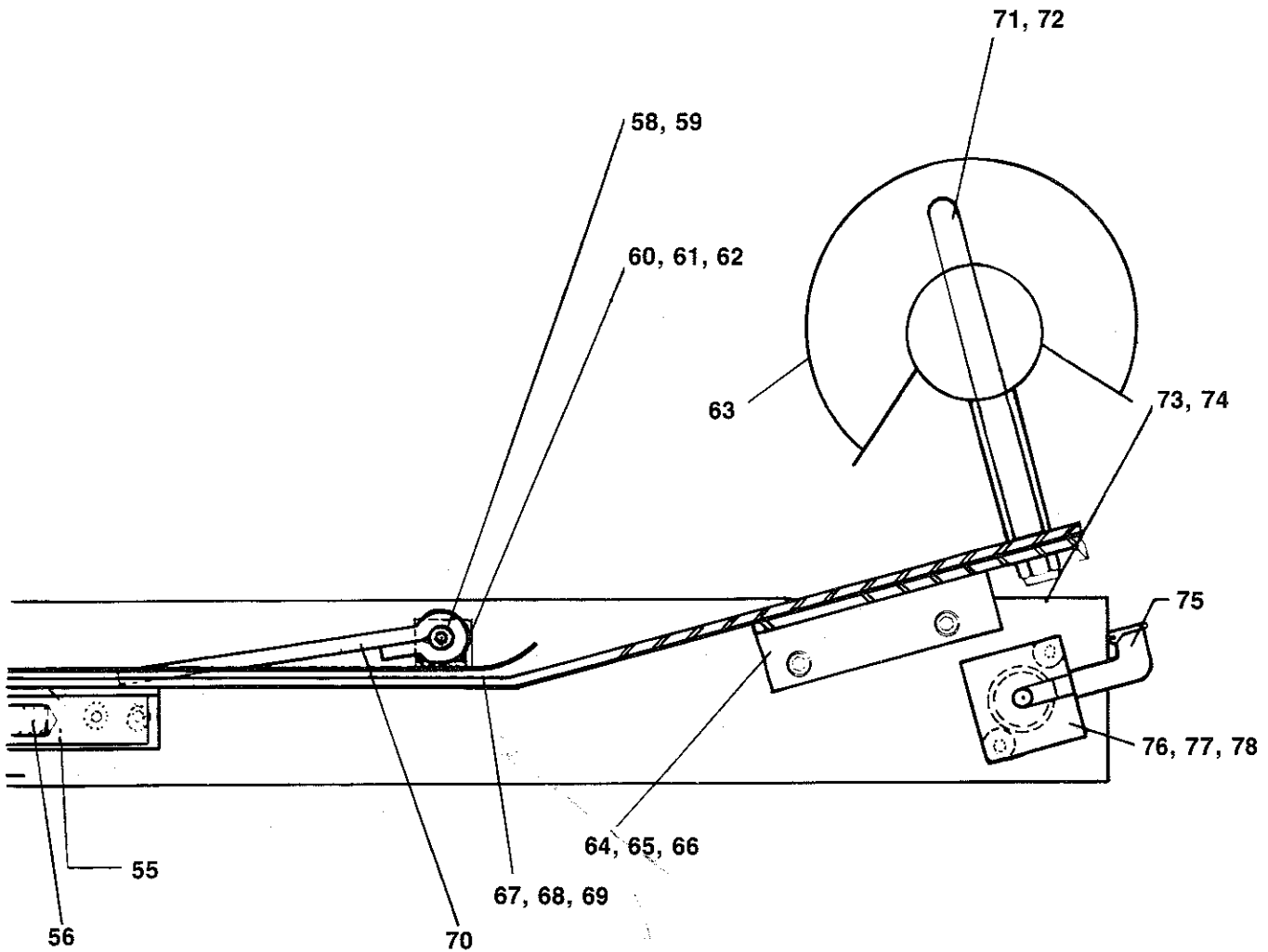

ITEM NO.	PART NO.	DESCRIPTION	ITEM NO.	PART NO.	DESCRIPTION
41	FC9714	Lock Rod	60	FC9544A	Top Guide Assembly
42	FC9713	Lock Rod Housing	61	UA2806.1	Screw
43	FC9549	Lock Spring	62	SW8E	Lock Washer
44	FC9507	Interlocking Block	63	FC9891W	Coil Holder Complete
45	FC9718A	Head Casting Assembly	64	FC9542	Guide Bar Support
46	FC9503A	Interlocking Bracket Assembly	65	UA3806.3	Screw
47	C40C	Driver Stop	66	SW10E.2	Lock Washer
48	C41B	Driver Stop Spring	67	FC9541	Staple Guide Bar
49	FC9680	Spring Plate	68	UA3806.18	Screw
50	UA3806.3	Screw	69	HN1032	Nut
51	LW10	Lock Washer	70	FC9558	Oiler Felt
52	FC9502B	Top Guide	71	FC9692	Magazine Stud
53	UA3806.9	Screw	72	HN1420.13	Nut
54	SW10	Lock Washer	73	FC9538	Side Plate L.H.
55	FC257A	Anvil Assembly	74	FC9539	Side Plate R.H.
56	FC9523	Supporter Spring	75	85243	Oiler
57	FC9513	Lock Spring	76	FC9618A	Pivot Block Complete
58	UA3814	Screw	77	UA3808.11	Screw
59	HN1032	Nut	78	SW10E.2	Lock Washer

MAINTENANCE

1. CLINCHER POST PIVOT ADJUSTMENT

In case of looseness in the clincher pivots, loosen the clincher pivot nuts and tighten the clincher pivots to remove all looseness, then retighten the nuts. Check clincher adjustment. Do not overtighten clincher pivots otherwise binding will prevent smooth operation and return of foot pedal.

2. DRIVER REPLACEMENT

- a. Remove door assembly.
- b. Remove driver spacer.
- c. Slide driver down until it is free of head.
- d. Replace by reversing instructions. Be sure bevel is facing in and word "Front" is facing out.

3. FORMER REPLACEMENT

- a. Manually lower the head until the interlock is engaged.
- b. Remove the driver as described above.
- c. Remove the cross bar assembly screw and raise the head up. Swing the cross bar under the head. Lower the head and rest it on the cross bar.
- d. Remove both front plates.
- e. Pull former forward until free.
- f. Replace by reversing instructions.

NOTE: It is recommended after replacing parts that the machine be manually turned over for one full cycle to make certain all parts operate freely. To manually cycle machine first turn machine switch off and disconnect power. Remove belt guard cover. Manually lift the solenoid actuated lever off the electric clutch. Manually turn the flywheel counterclockwise. The clutch should engage and the head can be turned through one full cycle.

▲ WARNING:

If not manually turned through a full cycle, the head will return to its normal position when turned on.

Stand clear of stapling head when turning machine on.

4. V-BELT ADJUSTMENT OR REPLACEMENT

With the machine off and the power disconnected, remove the belt guard. Loosen the two bolts holding motor bracket to frame. The motor and bracket are now free to slide as required to enable belt replacement and/or belt tension adjustment. Install belt guard when finished.

5. CLUTCH - BRAKE UNIT

This stapler is equipped with a solenoid actuated, continuous trip, wrap spring, clutch-brake unit. It is a dependable device that seldom needs service, but should a malfunction occur, the following information will serve as a service and trouble shooting guide for maintenance of this unit.

A.—LUBRICATION

The clutch-brake unit is designed with bearings made from oil impregnated sintered metal which normally does not need to be re-lubricated. In cases where there is severe duty, or the environment is such that it may "wick-out" oil wash off oil, or fill the clutch with foreign matter, the unit may be re-oiled or flushed out with minimal or no disassembly by using a light bearing oil as used in manufacture (Shell Bearing Infusion Oil #33). If disassembly of the unit for cleaning and oiling is necessary, follow the detailed disassembly instructions to the point needed, flush and wipe parts in the oil to be used for re-lubrication. **DO NOT USE SOLVENT** to clean the parts. To get more cleaning action from the oil, it may be heated while cleaning the components, but bring the parts back to ambient temperature submerged in cool oil.

B.—ACTUATOR

The actuator is a linkage driven by a solenoid which is controlled by a microswitch inside the front leg of the machine. When the actuator does not trip the following checks should be made:

Problem	Cause and remedy
1. No power to the coil.	1. If no power to the coil, check all wiring and switching in the system that actuates the clutch.
2. Lack of continuity of the coil windings.	2. If no continuity, replace the coil.
3. Mechanical binding of the plunger.	3. Plunger binding may be caused by the shifting of the coil, or mushrooming of plunger end due to striking the back stop. In the latter case the plunger may be turned or filed to its true diameter.
4. Insufficient clearance of the actuator over the stop collar.	4. No clearance over the stop collar detent would be caused by lack of continuity of the linkage. Repair or adjust as needed.

5. Actuator loaded by the stop collar, in which case the collar pushes so hard on the actuator that it cannot be pulled by the coil.	5. Actuator loading can be caused by the braking force exceeding the limits of the brake or the differential setting of the unit being too close, i.e., CLUTCH ON BRAKE ON. (See instructions of setting on Assembly and Disassembly Instructions.)
--	---

C.—CLUTCH AND BRAKE SPRINGS

With the brake engaged (full limit of output), the input hub should be free to rotate by hand. With the clutch engaged, the input and output should rotate together. If the unit does not rotate in either of these modes, the clearance between the hubs of the unit on the shaft may have been disturbed by dropping or hammering the unit on the shaft at assembly.

See Assembly and Disassembly instructions for readjusting.

Listed below are additional checks to be made if the clutch does not function correctly.

Problem	Cause and remedy
1. Clutch Brake does not drive but input turns	A. Drive spring may be broken at crossover point from an overload caused by a jam. Replace spring and check hubs for damage. B. Collar may not snap forward because of foreign matter restricting movement. Clean unit. C. Actuator does not pull in. (See "Actuator.")
2. Clutch-Brake jams and stalls input motor.	A. Spring tang broken off drive spring, not allowing clutch to disengage while brake is engaged. Replace drive spring. B. Clutch output bound up. Check clearance between output hub and break hub. C. Completely out of adjustment caused by losing an internal spring tang. Replace spring.
3. Output does not repeat stopping point.	A. Not enough inertia to actuate brake. B. Tang broken off brake spring. Replace spring. C. If unit has an adjustable collar, locking screw may be loose allowing adjusting screw to rotate.

CLUTCH AND BRAKE UNIT

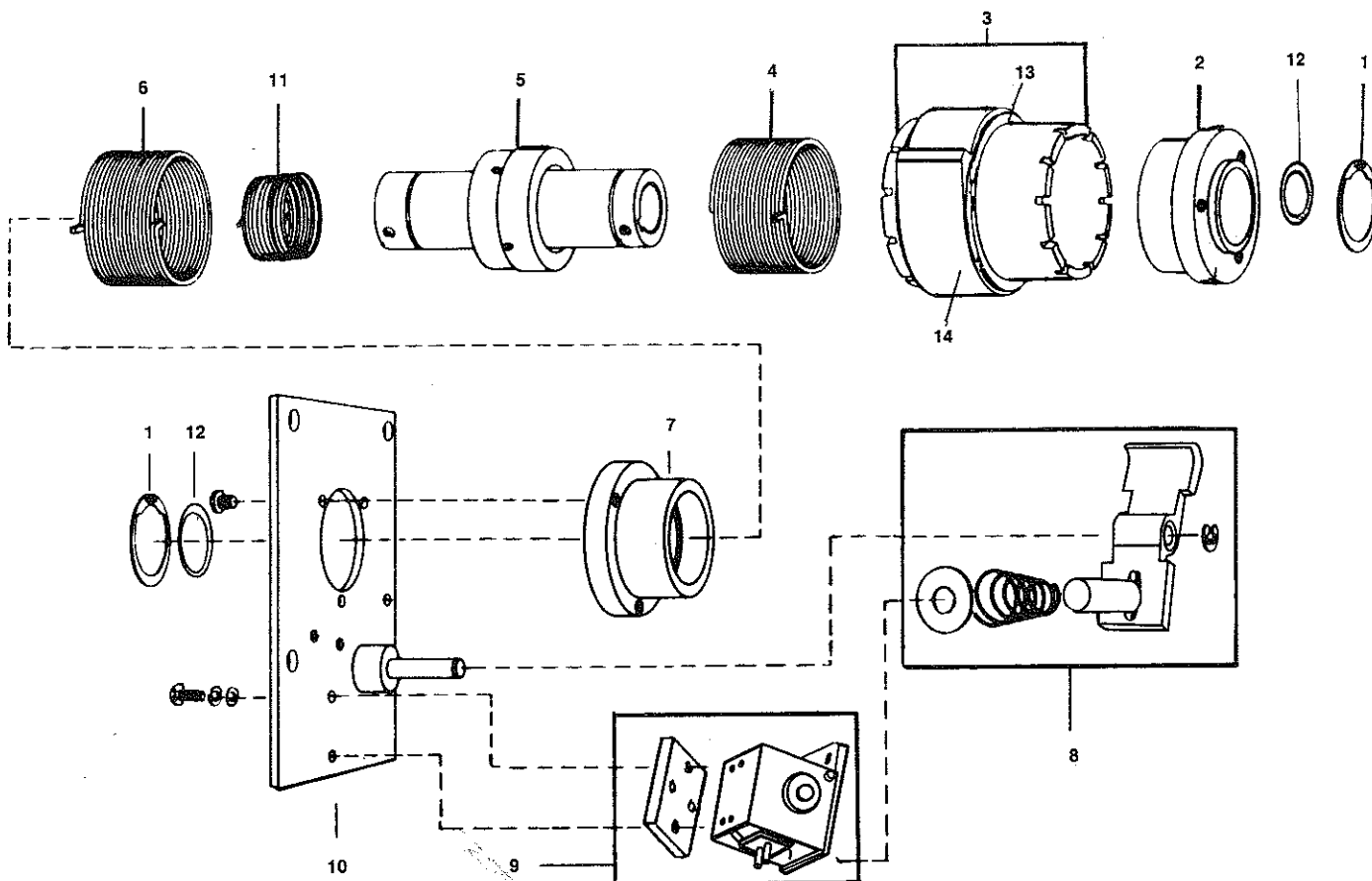

ITEM NO.	PART NO.	DESCRIPTION	ITEM NO.	PART NO.	DESCRIPTION
1	850886	Retaining Ring	9	107298	Coil Assembly (For 115V Service 50/60 Hz)
2	851321	Input Hub		107299	Coil Assembly (For 230V Service 50/60 Hz)
3	850888	Control Collar Assembly — CW	10	850890	Plate Assembly
4	850889	Spring-Drive — CW	11	850962	Anti-Back Up Spring
5	850891	Output Assembly	12	851126	Shim Washer
6	850889	Spring-Brake — CW	13	851243	Retaining Ring
7	850892	Brake Hub	14	851766	Control Collar Cam
8	107300	Actuator Assembly (6 pieces)			

D.—DISASSEMBLY

When disassembling the clutch-brake unit, always mark the spring tang locations with reference to which slots they go in if the same springs are to be used in reassembly.

▲ WARNING: Always disconnect stapler machine power cord from power outlet before any disassembly work.

To disassemble the clutch-brake unit it will first be necessary to remove the drive pulley from the stapler by removing the V-belt, retaining ring and disconnecting anchor strap from clutch plate.

Disconnect wires from solenoid, swing Anchor Bracket down out of way and carefully slide pulley and clutch off as a unit. Remove drive pulley from input hub then:

- a. Release Actuator Lever so that clutch is engaged and brake released.
- b. Remove Retaining Ring and Shim Washer, if any, from the input Hub end.
- c. Remove Input Hub, by rotating opposite to the drive direction.
- d. Remove Retaining Ring and Shim Washer, if any, from the Mounting Plate end.
- e. Remove Output Shaft, Springs, and Control Collar assembly, by rotating Output Shaft in the drive direction. (DO NOT DISASSEMBLE BRAKE HUB FROM MOUNTING PLATE.)
- f. Remove Control Collar from the Output Shaft and Spring assembly, by extracting towards the Brake Spring end.

E.—ASSEMBLY

- a. Replace Clutch Brake and anti back up Springs as required. (Assemble springs concentric and square to the Output Shaft.)
- b. Assemble Control Collar over the Output Shaft and Spring assembly, by inserting from the Brake Spring end. (It will be necessary to extend Brake Spring using long nose pliers.)
- c. Place the Brake Spring tang in any one of the nine (9) Control Collar slots at *random*.
- d. Assemble Output Shaft, Springs, and Control Collar assembly to the Mounting Plate assembly by rotating Output Shaft in the drive direction.
- e. Assemble Retaining Ring to Output Shaft at the Mounting Plate end (smooth surface facing Brake Hub.) Check end play between hub and retaining ring with feelers gauge. There should be .004 to .010 end. Use shim washers to adjust.
- f. Rotate Output Shaft in the drive direction, until it reaches a full brake position.
- g. With the *Clutch Spring Tang not* in slot, insert the Input Hub by rotating opposite to the drive direction.
- h. Select the one of ten (10) Control Collar slots for the Clutch Spring Tang that will provide a .38 to .50" circumferential overtravel of the Control Collar when released.

Note: At this point it may be necessary to reselect one (1) of the nine (9) Control Collar slots for the Brake Spring tang (release Actuator Lever, remove Clutch Spring Tang from slot, then remove Control Collar axially towards the Input Hub end and rotate it opposite to the drive direction to pick up next slot).

- i. Repeat Step (h) until the .38" to .50" specification is achieved.
- j. Assemble Retaining Ring to Output Shaft at the Input Hub end (smooth surface facing Input Hub). Check end play between Input Hub and Retaining Ring with feeler gauge. There should be .002 to .005 end play on Input Hub.
- k. Reassemble unit to machine.

IMPORTANT: After Clutch is assembled to machine, the Clutch Plate should be free to float on bearing - the Anchor Strap is only to prevent Plate rotation.

F.—CONTROL COLLAR ADJUSTMENT

The stopping position of the head can be changed if necessary by adjusting the position of the stop cam on the control collar sleeve. Turn power off, trip clutch by hand and rotate drive pulley until driver is in desired stopping position then proceed as follows:

- a. Work retaining ring "A" out of groove and slide forward on sleeve "C" (See illustration below).
- b. Slide cam "B" off splines, rotate to desired relationship of stop to shaft keyway, and slide back on splines. The actuator prawl will have to be held clear during this operation.
- c. Slide retaining ring back into groove.

NOTE: Make sure brake is locked up before proceeding to insure getting proper stop point.

INSTRUCTIONS FOR COIL REPLACEMENT

1. Place the spring onto the plunger with the narrow end towards the actuator then slide the nylon washer onto the plunger. Slide the solenoid and spacer plate onto the actuator/plunger assembly. Secure the solenoid and spacer plate with the cap screws and washers. *DO NOT* tighten more than finger tight.
2. Energize the coil and adjust the gap between the actuator and the top of the collar stop .015 to .030 inches by sliding the solenoid assembly. (NOTE: push the collar towards the actuator to allow for collar movement.) Tighten the cap screws.

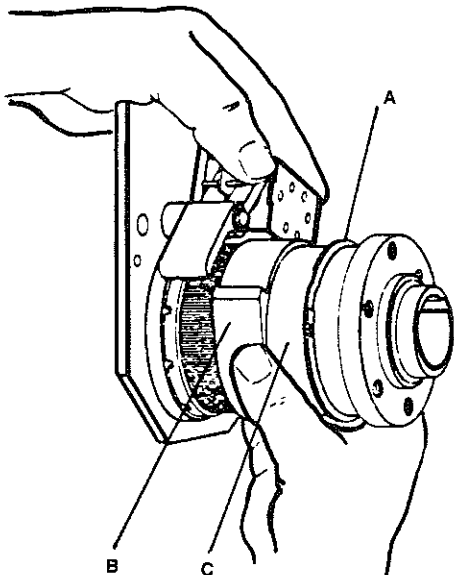

LIMITED WARRANTY

Stanley-Bostitch, Inc., warrants to the original retail purchaser that this product is free from defects in material and workmanship, and agrees to repair or replace, at Stanley-Bostitch's option, any defective product within ~~90 days~~ ^{one year} from the date of purchase. This warranty is not transferable. It only covers damage resulting from defects in material or workmanship, and it does not cover conditions or malfunctions resulting from normal wear, neglect, abuse or accident.

THIS WARRANTY IS IN LIEU OF ALL OTHER EXPRESS WARRANTIES. ANY WARRANTY OF MERCHANTABILITY OR FITNESS FOR A PARTICULAR PURPOSE IS LIMITED TO THE DURATION OF THIS WARRANTY. STANLEY-BOSTITCH SHALL NOT BE LIABLE FOR ANY INCIDENTAL OR CONSEQUENTIAL DAMAGES.

Some states do not allow limitations on how long an implied warranty lasts, or the exclusion or limitation of incidental or consequential damages, so the above limitations or exclusions may not apply to you. This warranty gives you specific legal rights, and you may also have other rights which vary from state to state.

To obtain warranty service, you must return the product at your expense together with proof of purchase to a Stanley-Bostitch Regional warranty repair center listed below or you may call us at 1-800-556-6696 or 1-800-832-3080 for the location of additional authorized warranty service locations in your area.