

## Important

To assure product SAFETY and RELIABILITY, repairs, maintenance and adjustment should be performed by BLACK & DECKER Service Centers or other qualified service organizations, always using Black & Decker replacement parts.

## Warranty

Black & Decker (U.S.) Inc. warrants this product for one year from date of purchase. We will repair without charge, any defects due to faulty material or workmanship. Please return the complete unit, transportation prepaid, to any Black & Decker Service Center or Authorized Service Station listed under "Tools Electric" in the yellow pages. This warranty does not apply to accessories or damage caused where repairs have been made or attempted by others.

Like most Black & Decker products your tool is listed by Underwriters Laboratories to ensure that it meets stringent safety requirements.



This symbol on the nameplate means the product is listed by Underwriters Laboratories, Inc.



See 'Tools-Electric'  
-Yellow Pages-  
for Service & Sales

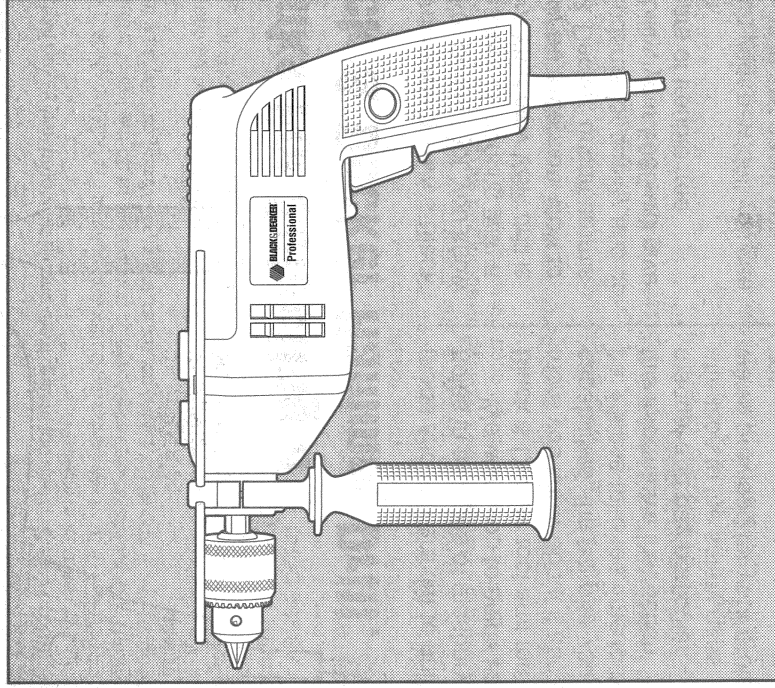

# Instruction Manual

## 1/2" Dual Range Hammer Drill 5065

**BLACK & DECKER**

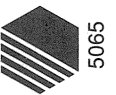

5065

Form No. 741782  
Printed in Italy  
©1989 Black & Decker (April 89)  
Black & Decker (U.S.) Inc., U.S. Power Tools Group, P.O. 798, Hunt Valley, MD 21030-0798 U.S.A.

## Additional Safety Information For Drills

1. The switch lock feature must be used with caution due to the high torque output of the tool (See Figure 1).
2. Do not attempt to change from hammer to drill mode while tool is running.

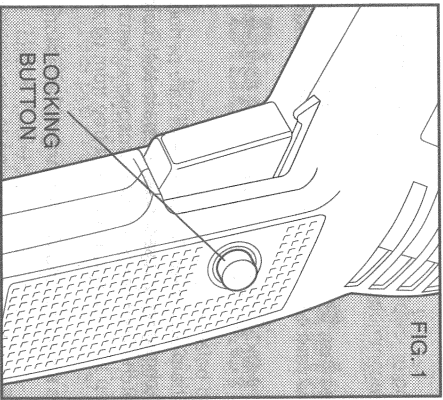

## Switches

To start unit, depress trigger switch; to stop unit, release trigger. To lock trigger in "ON" position for continuous operation, depress trigger and push in locking button Figure 1, then gently release trigger. To release locking mechanism, depress trigger fully, then release it. Before using the tool (each time) be sure that the lock button release mechanism is working freely.

Be sure to release the switch locking button before disconnecting the plug from the power supply. Failure to do so will cause the tool to start immediately the next time it is plugged in. Damage or injury could result.

**WARNING:** The switch lock feature must be used with caution due to the high torque output of this unit.

The Variable Speed Trigger Switch permits speed control. The farther the trigger is depressed, the higher the speed of the unit.

For maximum tool life, use lower speed only for starting the hole. Continuous use at lower speed is not recommended.

The Reversing Lever is used for removing jammed drill bits, or backing out screws. It is located above the trigger switch, as shown in Figure 2. To operate the tool, in reverse, push the reversing lever to the right, shown in Figure 2. When reversing operations are concluded, return the lever to the forward position, as shown in the figure.

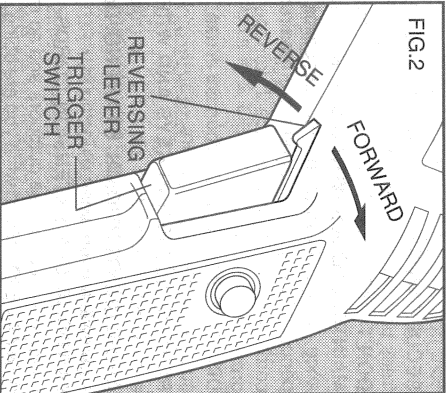

## Brushes

Your tool is equipped with Black & Decker brush checkpoint system. When the brushes become worn out the tool will automatically stop and prevent damage to the motor. Return the tool to a Black & Decker Service Center for brush replacement.

## Drill Stop

Capacity 1/4" to 1/2" Goversms drilling depth.

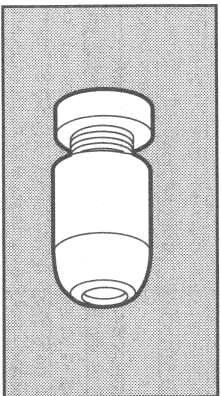

## Wire Wheel Brushes

Use in cleaning and removing rust, scale, old paint. 4" Fine Brush, crimped; Maximum safe RPM—4,500. 4" Coarse Brush, crimped; Maximum safe RPM—4,500.

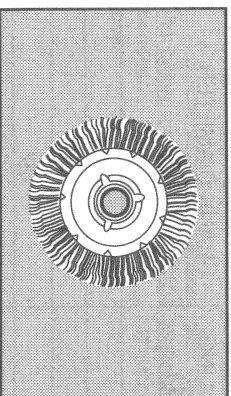

## Wheel Arbors

Fit 1/4" to 1/2" Drills. Carry wire wheel brushes and buffing wheels.

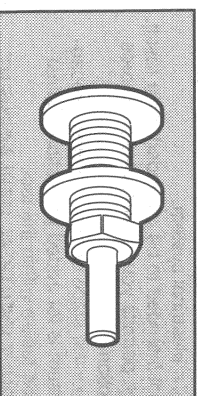

## Buffing Wheels

Use with 1/4" to 1/2" Drills and Wheel Arbors. 3" x 3/8" x 1/2" Cotton Buff.

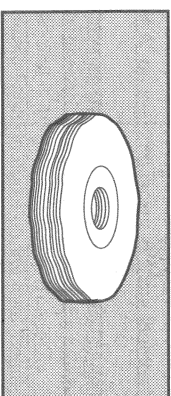

## Rubber Backing Pad

Fit 1/4" to 1/2" Drills. 4-5/8" Rubber Backing Pad with plain shank. Used for sanding operations.

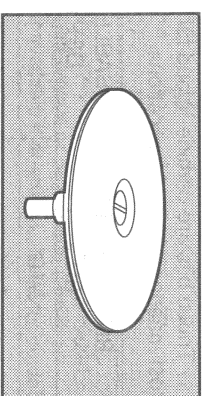

## Sanding Discs

Use with Rubber Backing Pad.

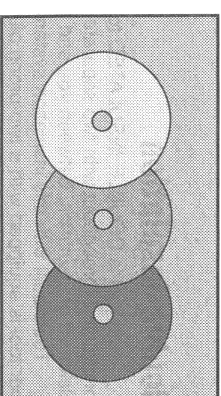

## Drilling in Masonry

Refer to the same list of instructions under "DRILLING", but use percussion Masonry drill bits only. Drill in masonry only. Keep even force on the drill but not so much that you crack the brittle materials. A smooth, even flow of dust indicates the proper drilling rate.

## Drill Accessories

The accessories listed in this manual are available at extra cost from your local dealer or Black & Decker Service Center. A complete listing of service centers is included on the owner's registration card packed with your tool.

If you need assistance in locating any accessory, please contact: Black & Decker, (U.S.) Inc., User Services Department, 626 Hanover Pike, P.O. Box 618, Hampstead, MD 21074-0618.

Every Black & Decker tool is of the highest quality. If you wish to contact us regarding this product, please call toll free between 8:00 a.m. and 5:00 p.m. EST Monday through Friday. 1-800-762-6672

Recommended accessories for your Drill are shown in this manual (**CAUTION:** The use of any other accessory might be hazardous.) For safety in use, the following accessories should be used only in sizes up to the maximums shown in the table below.

## Maximum Recommended Capacities

DRILL CAPACITY	
R.P.M.	0-900/0-2200
BITS, METAL DRILLING	1/2"
WOOD, FLAT BORING	1"
BITS, MASONRY DRILLING	3/4"
HOLE SAWS	1-1/8"
WIRE WHEEL BRUSHES	4" Dia. Max.
WIRE CUP BRUSHES	3" Dia. Max.
BUFFING WHEELS	3" Dia. Max.
RUBBER BACKING	4-5/8" Dia. Max.

ACCESSORY MUST BE RATED FOR USE AT SPEED EQUAL TO OR HIGHER THAN NAMEPLATE R.P.M. OF TOOL WITH WHICH IT IS BEING USED.

## Carbon Removing Brushes

Made of tempered-steel wire; used with drills to remove rust and scale from metals. Leaves a burnished surface.

- Heavy-duty solid wire-filled brush.
- Side-flare brush for close corner work.
- Hollow-core, flare-bottom brush. Small cleaning brush. (Not shown.)

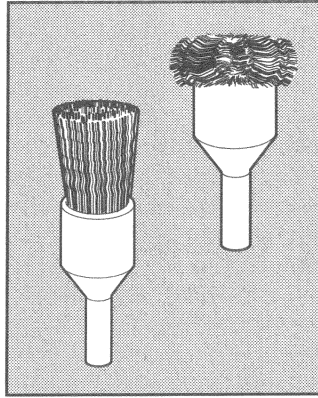

## 3" Wire Cup Brush

Use in cleaning and removing rust, scale, old paint. (Straight chuck shank). Maximum safe RPM—5,000.

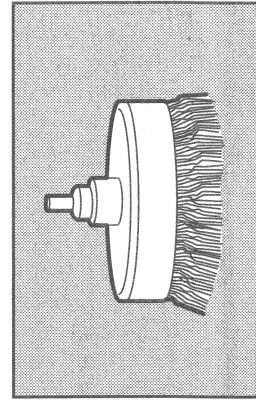

## Dual Range Speed Control

Your Hammer Drill is equipped with dual range speed control for greater versatility. To change from one range to the other, turn the tool off and then rotate the range control dial, shown in Figure 3, to the desired position. Turn the dial so that the symbol I is toward the chuck for low speed (0-900 RPM). If you want high speed (0-2200 RPM) turn the dial so that the symbol II is toward the chuck.

**NOTE:** It may sometimes be necessary to manually turn the spindle slightly when shifting from one range to another. **DO NOT SHIFT WHEN THE TOOL IS RUNNING OR COASTING.**

The tool must be fully engaged into range I or range II. Make sure that the selector is not somewhere between the two; damage to the unit may result.

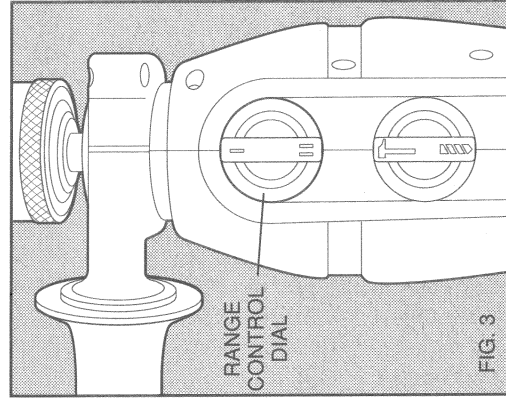

## Hammer/Drill Selector

To switch the tool from the drilling mode to the hammering mode (or vice-versa) rotate the dial, shown in Figure 4, so that the desired position is accomplished. For straight drilling, align the drill bit symbol

toward the chuck. For hammering, align the hammer symbol with the chuck, as shown in the figure.

**NOTE:** The selector must be in either drill or hammer mode at all times. There are no operable positions between the two.

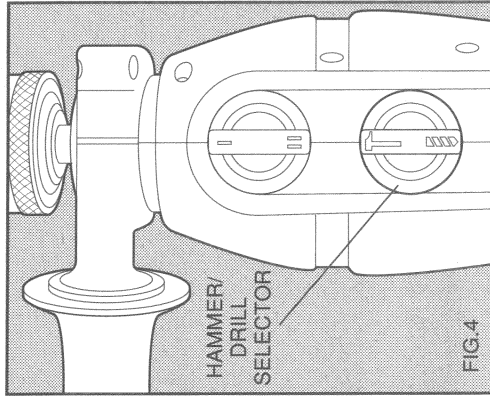

## Chuck and Key

**UNPLUG DRILL.** Open chuck jaws and insert shank of bit about 1" into chuck. Tighten chuck collar by hand. Place chuck key in each of the three holes, and tighten in clockwise direction. It's important to tighten chuck with all three holes to prevent slippage of drill bit in chuck. To release bit, turn chuck key counterclockwise in just one hole, then loosen chuck by hand.

## Chuck Key Holder

- Push double-hole end of Holder through slot in other end of Holder. (Figure 5).
- Slip loop over electric plug and draw loop tight around cord (Figure 6).
- Push ends of Chuck Key Handle through two holes in end of Holder (Figure 7).

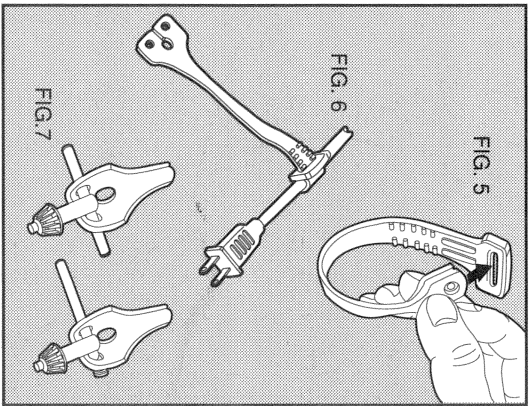

### Multi-Position Side Handle

This handle clamps to the front of the tool and can be rotated to permit right-hand or left-hand use. (Figure 8).

**CAUTION:** Always use Side Handle and hold drill with both hands.

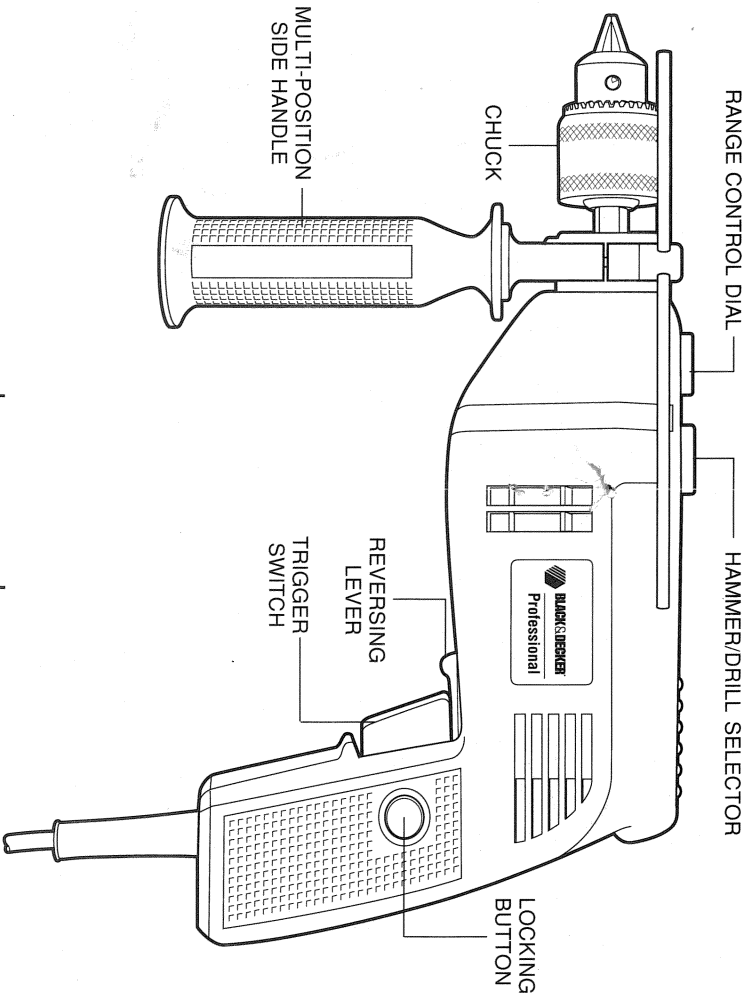
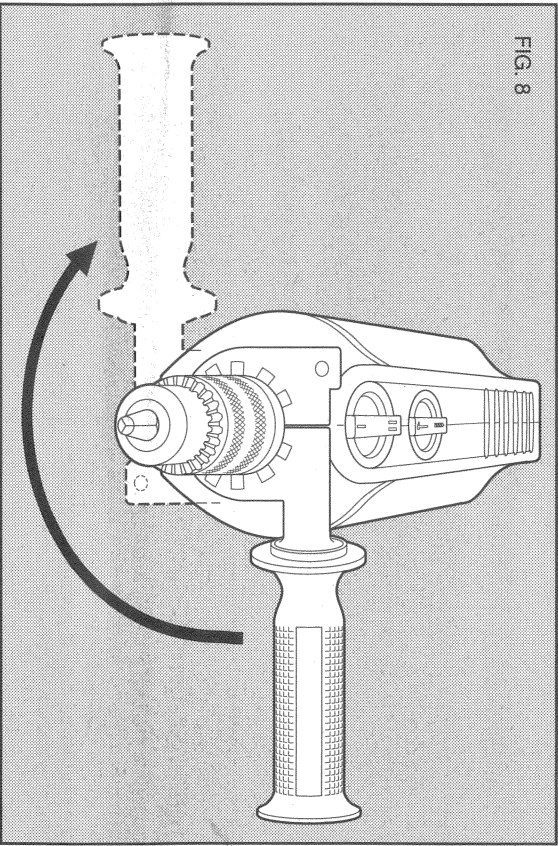

FIG. 8



### Operation

#### DRILLING

1. Always unplug the Drill when attaching or changing bits or accessories.
2. Use sharp drill bits only. For WOOD, use twist drill bits, spade bits, power auger bits, or hole saws. For METAL, use high speed steel twist drill bits or hole saws.
3. Be sure the material to be drilled is anchored or clamped firmly. If drilling thin material, use a wood "back-up" block to prevent damage to the material.
4. Always apply pressure in a straight line with the bit. Use enough pressure to keep drill biting, but do not push hard enough to stall the motor or deflect the bit.

5. Hold tool firmly to control the twisting action of the drill.
6. **IF DRILL STALLS**, it is usually because it is being overloaded or improperly used. **RELEASE TRIGGER IMMEDIATELY**, remove drill bit from work, and determine cause of stalling. **DO NOT CLICK TRIGGER OFF AND ON IN AN ATTEMPT TO START A STALLED DRILL — THIS CAN DAMAGE THE DRILL.**
7. To minimize stalling or breaking through the material, reduce pressure on drill and ease the bit through the last fractional part of the hole.
8. Keep the motor running when pulling the bit back out of a drilled hole. This will help prevent jamming.
9. With Variable Speed Drills there is no need to center punch the point to be drilled. Use a slow speed to start the hole and accelerate by squeezing the trigger harder when the hole is deep enough to drill without the bit skipping out.

### Drilling in Metal

Use a cutting lubricant when drilling metals. The exceptions are cast iron and brass which should be drilled dry. The cutting lubricants that work best are sulphurized cutting oil or lard oil; bacon-grease will also serve the purpose.

**NOTE:** Large (5/16" to 3/8") holes in steel can be made easier if a pilot hole (5/32" to 3/16") is drilled first.

### Drilling in Wood

Holes in wood can be made with the same twist drills used for metal. These bits may overheat unless pulled out frequently to clear chips from the flutes. For larger holes, use Power Drill Wood Bits. Work that is apt to splinter should be backed up with a block of wood.

## Drilling in Masonry

Refer to the same list of instructions under "DRILLING", but use percussion Masonry drill bits only. Drill in masonry only. Keep even force on the drill but not so much that you crack the brittle materials. A smooth, even flow of dust indicates the proper drilling rate.

## Drill Accessories

The accessories listed in this manual are available at extra cost from your local dealer or Black & Decker Service Center. A complete listing of service centers is included on the owner's registration card packed with your tool.

If you need assistance in locating any accessory, please contact: Black & Decker, (U.S.) Inc., User Services Department, 626 Hanover Pike, P.O. Box 618, Hampstead, MD 21074-0618.

Every Black & Decker tool is of the highest quality. If you wish to contact us regarding this product, please call toll free between 8:00 a.m. and 5:00 p.m. EST Monday through Friday. 1-800-762-6672

Recommended accessories for your Drill are shown in this manual (CAUTION: The use of any other accessory might be hazardous.) For safety in use, the following accessories should be used only in sizes up to the maximums shown in the table below.

## Maximum Recommended Capacities

DRILL CAPACITY	
R.P.M.	0-900/0-2200
BITS, METAL DRILLING	1/2"
WOOD, FLAT BORING	1"
BITS, MASONRY DRILLING	3/4"
HOLE SAWS	1-1/8"
WIRE WHEEL BRUSHES	4" Dia. Max.
WIRE CUP BRUSHES	3" Dia. Max.
BUFFING WHEELS	3" Dia. Max.
RUBBER BACKING	4-5/8" Dia. Max.

ACCESSORY MUST BE RATED FOR USE AT SPEED EQUAL TO OR HIGHER THAN NAMEPLATE R.P.M. OF TOOL WITH WHICH IT IS BEING USED.

## Carbon Removing Brushes

Made of tempered-steel wire; used with drills to remove rust and scale from metals. Leaves a burnished surface.

- Heavy-duty solid wire-filled brush.
- Side-flare brush for close corner work.
- Hollow-core, flare-bottom brush. Small cleaning brush. (Not shown.)

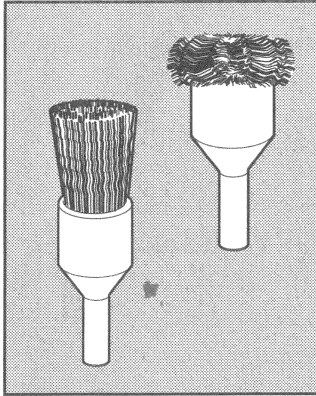

## 3" Wire Cup Brush

Use in cleaning and removing rust, scale, old paint. (Straight chuck shank). Maximum safe RPM—5,000.

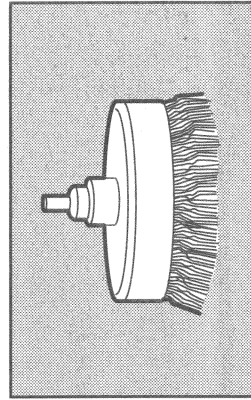

## Dual Range Speed Control

Your Hammer Drill is equipped with dual range speed control for greater versatility. To change from one range to the other, turn the tool off and then rotate the range control dial, shown in Figure 3, to the desired position. Turn the dial so that the symbol I is toward the chuck for low speed (0-900 RPM). If you want high speed (0-2200 RPM) turn the dial so that the symbol II is toward the chuck.

NOTE: It may sometimes be necessary to manually turn the spindle slightly when shifting from one range to another. DO NOT SHIFT WHEN THE TOOL IS RUNNING OR COASTING.

The tool must be fully engaged into range I or range II. Make sure that the selector is not somewhere between the two; damage to the unit may result.

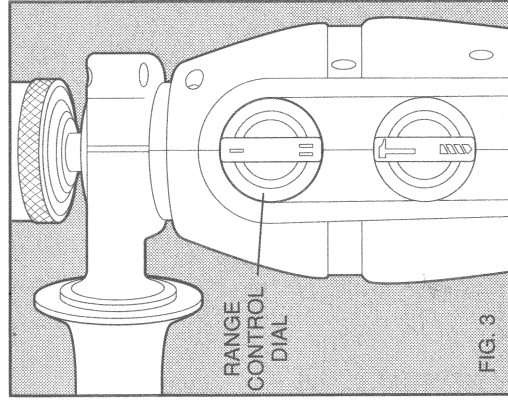

## Hammer/Drill Selector

To switch the tool from the drilling mode to the hammering mode (or vice-versa) rotate the dial, shown in Figure 4, so that the desired position is accomplished. For straight drilling, align the drill bit symbol

toward the chuck. For hammering, align the hammer symbol with the chuck, as shown in the figure.

NOTE: The selector must be in either drill or hammer mode at all times. There are no operable positions between the two.

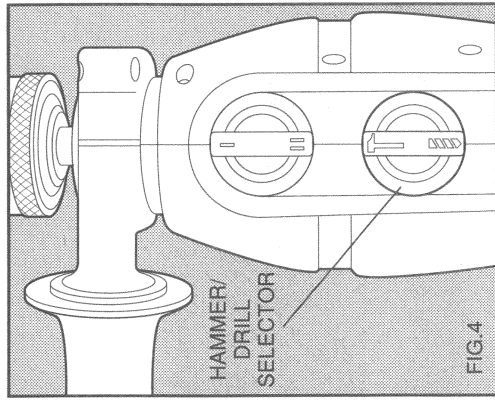

## Chuck and Key

**UNPLUG DRILL.** Open chuck jaws and insert shank of bit about 1" into chuck. Tighten chuck collar by hand. Place chuck key in each of the three holes, and tighten in clockwise direction. It's important to tighten chuck with all three holes to prevent slippage of drill bit in chuck. To release bit, turn chuck key counterclockwise in just one hole, then loosen chuck by hand.

## Chuck Key Holder

- Push double-hole end of Holder through slot in other end of Holder. (Figure 5).
- Slip loop over electric plug and draw loop tight around cord (Figure 6).
- Push ends of Chuck Key Handle through two holes in end of Holder (Figure 7).

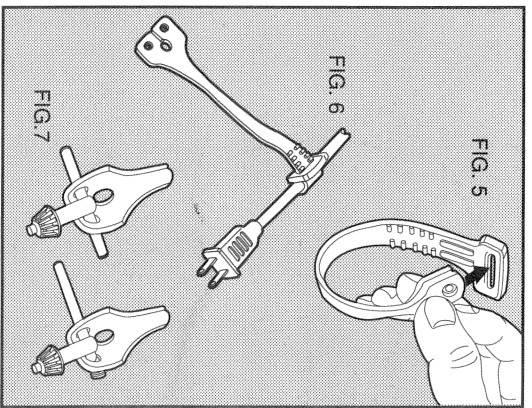

**Multi-Position Side Handle**

This handle clamps to the front of the tool and can be rotated to permit right-hand or left-hand use. (Figure 8).

**CAUTION:** Always use Side Handle and hold drill with both hands.

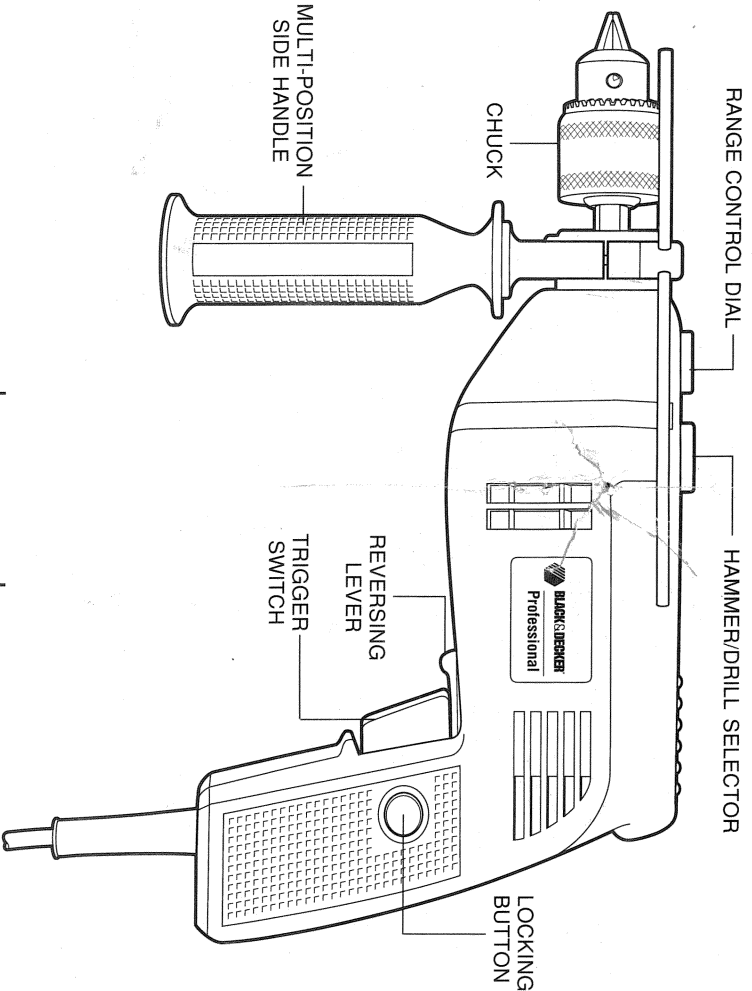
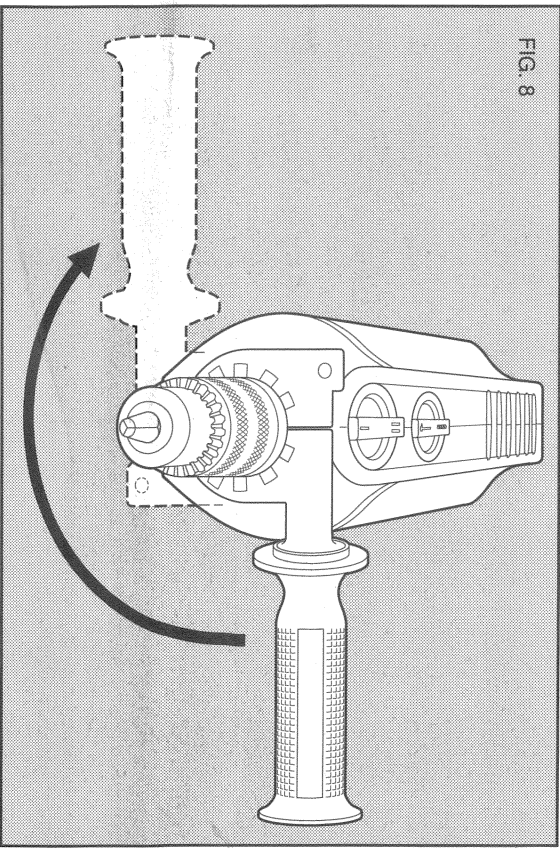

FIG. 8



## Operation

### DRILLING

1. Always unplug the Drill when attaching or changing bits or accessories.
2. Use sharp drill bits only. For WOOD, use twist drill bits, spade bits, power auger bits, or hole saws. For METAL, use high speed steel twist drill bits or hole saws.
3. Be sure the material to be drilled is anchored or clamped firmly. If drilling thin material, use a wood "back-up" block to prevent damage to the material.
4. Always apply pressure in a straight line with the bit. Use enough pressure to keep drill biting, but do not push hard enough to stall the motor or deflect the bit.

5. Hold tool firmly to control the twisting action of the drill.
6. **IF DRILL STALLS**, it is usually because it is being overloaded or improperly used. **RELEASE TRIGGER IMMEDIATELY**, remove drill bit from work, and determine cause of stalling. **DO NOT CLICK TRIGGER OFF AND ON IN AN ATTEMPT TO START A STALLED DRILL — THIS CAN DAMAGE THE DRILL.**
7. To minimize stalling or breaking through the material, reduce pressure on drill and ease the bit through the last fractional part of the hole.
8. Keep the motor running when pulling the bit back out of a drilled hole. This will help prevent jamming.
9. With Variable Speed Drills there is no need to center punch the point to be drilled. Use a slow speed to start the hole and accelerate by squeezing the trigger harder when the hole is deep enough to drill without the bit skipping out.

### Drilling in Metal

Use a cutting lubricant when drilling metals. The exceptions are cast iron and brass which should be drilled dry. The cutting lubricants that work best are sulphurized cutting oil or lard oil; bacon-grease will also serve the purpose.

**NOTE:** Large (5/16" to 3/8") holes in steel can be made easier if a pilot hole (5/32" to 3/16") is drilled first.

### Drilling in Wood

Holes in wood can be made with the same twist drills used for metal. These bits may overheat unless pulled out frequently to clear chips from the flutes. For larger holes, use Power Drill Wood Bits. Work that is apt to splinter should be backed up with a block of wood.