

---

**Black & Decker (U.S.) Inc. • 701 East Joppa Road, Towson, Maryland 21286**  
Printed in U.S.A. (DEC96-CD-1) Form No. 154568 Copyright © 1996

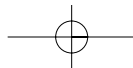



# **Instruction Manual**

## **3208-220 Swivel Head Shears**

### Getting the most out of your tool.

Please take time to read this manual and pay particular attention to the safety rules we've provided for your protection. If you have any questions about your tool please call:

**1-800-9-BD TOOL**  
**(1-800-923-8665)**

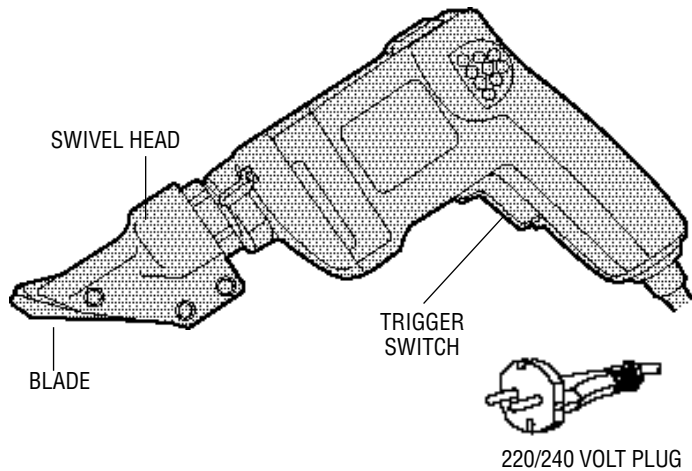

**3208-220 – 14-Gauge Swivel Head Shear (0-2500 Strokes Per Minute)**

## IMPORTANT SAFETY INSTRUCTIONS

**⚠ WARNING:** When using electric tools, basic safety precautions should always be followed to reduce risk of fire, electric shock, and personal injury, including the following:

**READ ALL INSTRUCTIONS**

### Double Insulation

Double insulated tools are constructed throughout with two separate layers of electrical insulation or one double thickness of insulation between you and the tool's electrical system. Tools built with this insulation system are not intended to be grounded. As a result, your tool is equipped with a two prong plug which permits you to use extension cords without concern for maintaining a ground connection.

**NOTE:** Double insulation does not take the place of normal safety precautions when operating this tool. The insulation system is for added protection against injury resulting from a possible electrical insulation failure within the tool.

**⚠ CAUTION:** WHEN SERVICING USE ONLY IDENTICAL REPLACEMENT PARTS. Repair or replace damaged cords.

### Safety Instructions For All Tools

- **KEEP WORK AREA CLEAN.** Cluttered areas and benches invite injuries.
- **CONSIDER WORK AREA ENVIRONMENT.** Don't expose power tools to rain. Don't use power tools in damp or wet locations. Keep work area well lit. Do not use tool in presence of flammable liquids or gases.
- **GUARD AGAINST ELECTRIC SHOCK.** Prevent body contact with grounded surfaces. For example; pipes, radiators, ranges, and refrigerator enclosures.
- **KEEP CHILDREN AWAY.** Do not let visitors contact tool or extension cord. All visitors should be kept away from work area.
- **STORE IDLE TOOLS.** When not in use, tools should be stored in dry, and high or locked-up place — out of reach of children.
- **DON'T FORCE TOOL.** It will do the job better and safer at the rate for which it was intended.
- **USE RIGHT TOOL.** Don't force small tool or attachment to do the job of a heavy-duty tool. Don't use tool for purpose not intended.
- **DRESS PROPERLY.** Do not wear loose clothing or jewelry. They can be caught in moving parts. Rubber gloves and non-skid footwear are recommended when working outdoors. Wear protective hair covering to contain long hair.
- **USE SAFETY GLASSES.** Also use face or dust mask if operation is dusty.
- **DON'T ABUSE CORD.** Never carry tool by cord or yank it to disconnect from receptacle. Keep cord from heat, oil, and sharp edges.
- **SECURE WORK.** Use clamps or a vise to hold work. It's safer than using your hand and it frees both hands to operate tool.
- **DON'T OVERREACH.** Keep proper footing and balance at all times.
- **MAINTAIN TOOLS WITH CARE.** Keep tools sharp and clean for better and safer performance. Follow instructions for lubricating and changing accessories. Inspect tool cords periodically and if damaged, have repaired by authorized service facility. Inspect extension cords periodically and replace if damaged. Keep handles dry, clean, and free from oil and grease.
- **DISCONNECT OR LOCK OFF TOOLS** when not in use, before servicing, and when changing accessories, such as blades, bits, cutters.
- **REMOVE ADJUSTING KEYS AND WRENCHES.** Form habit of checking to see that keys and adjusting wrenches are removed from tool before turning it on.
- **AVOID UNINTENTIONAL STARTING.** Don't carry tool with finger on switch. Be sure switch is off when plugging in.

- **EXTENSION CORDS.** Make sure your extension cord is in good condition. When using an extension cord, be sure to use one heavy enough to carry the current your product will draw. An undersized cord will cause a drop in line voltage resulting in loss of power and overheating. The following table shows the correct size to use depending on cord length and nameplate ampere rating. If in doubt, use the next heavier gage. The smaller the gage number, the heavier the cord.

Minimum Gage for Cord Sets

Volts	Total Length of Cord in Feet			
	0-25	26-50	51-100	101-150
120V	0-50	51-100	101-200	201-300
240V				
Ampere Rating		AWG		
More Than	Not more Than			
0	- 6	18	16	16 14
6	- 10	18	16	14 12
10	- 12	16	16	14 12
12	- 16	14	12	Not Recommended

- **OUTDOOR USE EXTENSION CORDS.** When tool is used outdoors, use only extension cords intended for use outdoors and so marked.
- **STAY ALERT.** Watch what you are doing. Use common sense. Do not operate tool when you are tired.
- **CHECK DAMAGED PARTS.** Before further use of the tool, a guard or other part that is damaged should be carefully checked to determine that it will operate properly and perform its intended function. Check for alignment of moving parts, binding of moving parts, breakage of parts, mounting, and any other conditions that may affect its operation. A guard or other part that is damaged should be properly repaired or replaced by an authorized service center unless otherwise indicated elsewhere in this instruction manual. Have defective switches replaced by authorized service center. Do not use tool if switch does not turn it on and off.
- **CAUTION:** When cutting into walls, floors or wherever live electrical wires may be encountered, DO NOT TOUCH ANY METAL PARTS OF THE TOOL! Hold the tool only by insulated grasping surfaces to prevent electric shock if you cut into a live wire.

**SAVE THESE INSTRUCTIONS**

## Motor

Your B&D tool is powered by a B&D built motor. Be sure your power supply agrees with the nameplate marking. Voltage decrease of more than 10% will cause loss of power and overheating. All B&D tools are factory tested; if this tool does not operate, check the power supply.

## Switch

To start tool, depress trigger switch. To stop tool, release the trigger.

**To lock the trigger in the on position for continuous operation,** depress trigger, push up the lock button (Figure 1), and gently release the trigger. To release the locking mechanism, depress the trigger fully, then release it. Before using the tool each time, be sure that the lock button release mechanism is working freely. Be sure to release the switch lock button before disconnecting the plug from the power supply. Failure to do so will cause the tool to start immediately the next time it is plugged in. Damage or injury could result. The **variable speed trigger switch** permits speed control. The farther the trigger is depressed, the higher the speed of the shear.

## Disassembly and Assembly (Figures 2 and 3)

**To remove shear head from motor,** loosen 3 cap screws. Remove shear head by pulling head firmly forward. Slight twisting action may be required if head does not slide off easily.

**To remove cutter blades from shear head,** remove 3 cap screws from shear housing. Be careful not to lose rear spacer bushing when removing middle cap screw. Remove center blade from housing by tapping blade gently towards the rear. Side knife and side spacer will now drop out of the housing.

**To remove eccentric bearing assembly from shaft,** use an appropriate wrench to loosen eccentric nut by turning counterclockwise.

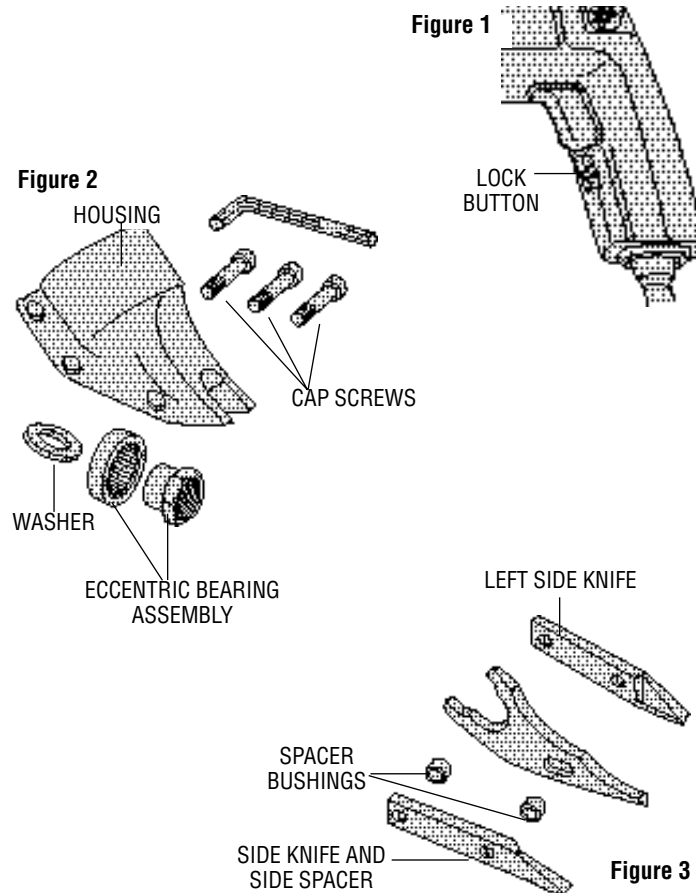

**To install eccentric bearing assembly onto shaft,** make sure the large thin washer is first inserted over shaft. Screw eccentric bearing assembly onto shaft and tighten with appropriate wrench. Lubricate bearing with a good grade of bearing grease.

**To install cutter blades into shear housing,** place the side knife and side spacer into position in the shear housing. Insert center cap screw through side knife and side spacer with rear spacer bushing between them. Start cap screw into thread just enough to hold blades in place. **DO NOT TIGHTEN.** Insert spacer bushing into hole in center blade and lubricate. Install center blade into shear housing by tapping blade gently forward using a drift to line up hole in center blade with forward holes in housing. Insert and tighten forward cap screw making sure spacer bushing in center blade stays in position. Apply good grade of bearing grease to clevis or yoke in center blade where it rides on the eccentric bearing assembly. Insert rear cap screw into shear housing but do not completely tighten.

**To install shear head assembly onto drive motor,** make sure all cap screws are loosened about 3 or 4 complete turns. Place shear head onto unit and alternately tighten cap screws snugly to lock head assembly in place. It may be necessary to gently tap the shear head into place if it does not readily slip onto the nose of the power unit.

## Operation

For accurate work, always clamp or anchor the material to be cut. Line up one edge of the tool's middle blade with the cutting line and advance blades into the material without forced effort or unnecessary pressure. A little practice will enable you to determine what forward pressure gives you the smoothest cutting. It is important to keep the lower surfaces of the side blades flat on the material being cut (Figure 4). When cutting curves, do not tilt the tool; keep the side blades flat and level. For best cutting efficiency, keep blades sharp. Wear gloves when handling sheet metal. The edges are sharp and can cause injury. **⚠ CAUTION:** Do not use the shear with any kind of accessory or attachment. Such usage might be hazardous.

## Adjustment (Figure 5)

To adjust the curl of waste material, the left side knife has elongated holes. Adjustment may be necessary after changing blades or material being cut. Loosen cap screws and tap side knife either forward or backward so that curl of waste does not hit shear housing or work material while cutting.

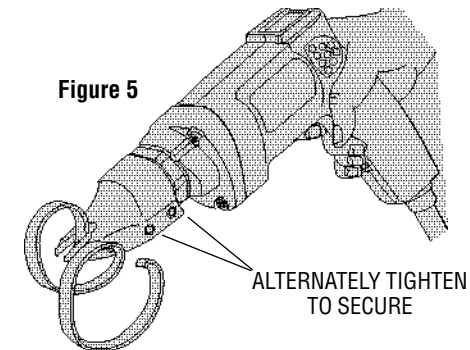
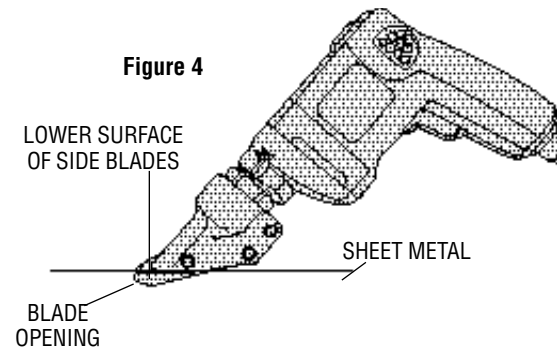

## Lubrication

All ball bearings are factory lubricated to last the life of the tool. All sleeve and needle bearings receive their lubrication from grease in the gear case. Clean and re-lubricate gear case yearly or whenever servicing requires the gear case to be removed. Use type and quantity of grease shown on the parts bulletin packed with your tool.

## IMPORTANT!

To assure product safety and reliability, particularly for double insulated tools, repairs, maintenance and adjustment (excluding maintenance described in this manual) should be performed by B&D service centers or authorized service centers, using identical B&D replacement parts.

## Accessories

Recommended accessories for use with your tool are available at extra cost from your distributor or local service center.

**⚠ CAUTION:** The use of any non-recommended accessory may be hazardous.

If you need assistance in locating any accessory call **1-800-9-BD TOOL:** (1-800-923-8665) or contact Black & Decker (U.S.) Inc., Consumer Services Department, 626 Hanover Pike, P.O. Box 618, Hampstead, MD 21074.

Every B&D tool is of the highest quality.

If you wish to contact us regarding this product, please call toll free between 8:00am and 8:00pm ET, seven days a week:

**1-800-9-BD TOOL**  
**(1-800-923-8665)**

## One Year Free Maintenance

All B&D tools for Industry and Construction are covered under a one year free maintenance program where B&D will inspect your tool for safety and provide necessary maintenance or repairs, including normal wear and tear parts, for one year, FREE OF CHARGE.

## Full Warranty

All B&D tools for Industry and Construction are warranted to be free of any defects in materials or workmanship. Upon thorough examination of tool, B&D will repair or replace, at our option, any product that is determined to be defective.

## Conditions

The service/safety check and the warranty do not apply to: repairs made or attempted by anyone other than an authorized B&D service location; misuse, abuse, neglect, improper application of the tool; missing parts; or normal wear and tear (after first year of ownership). Please return the complete unit, transportation prepaid, to any B&D factory owned or B&D authorized service center location (list provided with tool or see Yellow Pages under "Tools Electric").